

Price \$1.50

# GRAFMATIC® 45

SERVICE INSTRUCTIONS  
and  
PARTS CATALOG

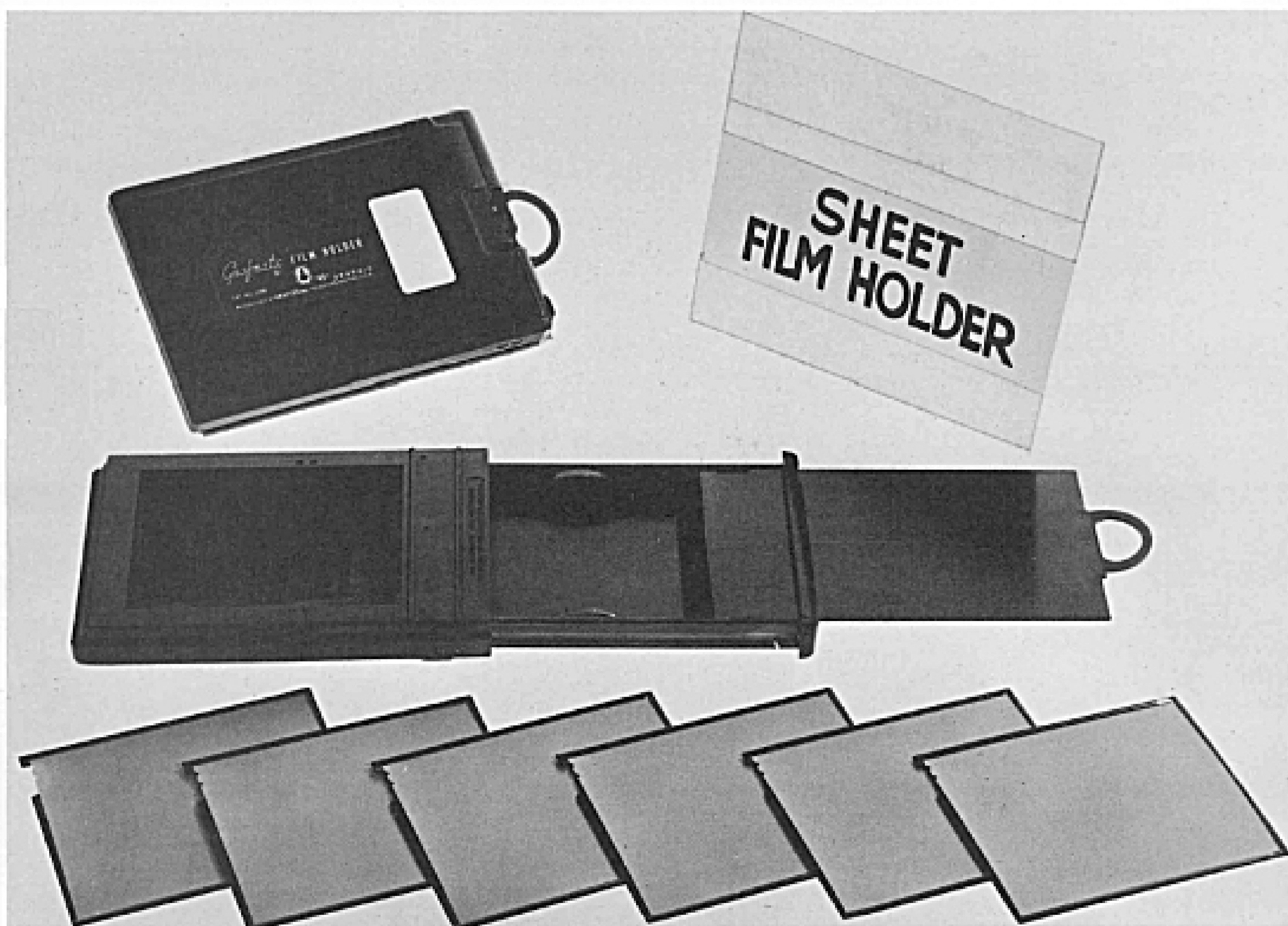

MARCH 1964

**GRAFLEX**

**GP GENERAL  
PRECISION**

GRAFLEX, INC. / A SUBSIDIARY OF GENERAL PRECISION EQUIPMENT CORPORATION  
ROCHESTER, NEW YORK 14603

PRINTED IN U.S.A.

## TABLE OF CONTENTS

Paragraph	Title	Page
1.	INTRODUCTION . . . . .	1
2.	OPERATION . . . . .	1
3.	INSPECTION and TROUBLES. . . . .	1 - 2
4.	DISASSEMBLY . . . . .	3
5.	CLEANING . . . . .	4
6.	REASSEMBLY. . . . .	4 - 5
	MATERIALS . . . . .	6

## PARTS LIST

Figure		Page
1.	Grafmatic 45 (Exploded View) . . . . .	8

## 1. INTRODUCTION

The 4x5 Graphic Grafmatic Film Holder (for Graflok Back) and the 4x5 Graflex Grafmatic Film Holder (for Graflex Back) is an automatic magazine holding six individual sheets of cut film. Besides indicating the exposure number, it has an indicator to tell whether the film is in the exposed position or covered. It also has a device numbering each negative as it is exposed.

The 4x5 Graphic Grafmatic holder is not recommended for use with Graphic Backs, since Graphic Backs do not have the facilities for locking the Grafmatic in place -- but if used, care must be taken to avoid accidental removal of the holder during operation. When the Grafmatic holder is used in a Graflok Back, slide it under the focusing panel and be sure to lock it in place with the slide locks.

## 2. OPERATION

Two movements are required -- PUSH and PULL. When pulling the slide or film compartment, pull straight outward -- not backward -- to avoid leverage pressure against the focusing panel or slide locks with possible danger of light leak. First check to see that the exposure counter dial is turned (use the edge of your thumb) so that the number "1" appears and that the drawer lock disc is turned to allow operation of the dark slide.

Pull the slide all the way out and push it all the way back. The first film septum will spring upward and be locked in the exposed position and the red dot at the back of the holder will be uncovered indicating that a film is in position ready for exposure.

After exposure the first film must be moved out of the way. To do this, press down with your thumb on the chrome latch holding it against the slide handle and PULL the entire film compartment all of the way out. Release the latch and PUSH the entire compartment in with the handle. When it is all the way in, the exposure counter dial will move to No. 2 and the red dot will be covered indicating that the film is covered and that the holder can be removed from the camera.

The same sequence is followed for all six exposures, after which an "X" will show on the exposure counter dial and both the slide and drawer will be locked in the compartment indicating the six exposures have been

made.

**NOTE:** The Grafmatic holder must be in the camera when the septums are being shifted. The film will be fogged if the film compartment is opened when the holder is not in the camera. To prevent accidental opening of the drawer (on early model) be sure the counter dial is set at a numbered position. To release the slide for recycling or loading turn the dial to No. 1.

To load or unload the Grafmatic film holder set the indicator dial on a number, press the chrome latch toward the handle and pull the film compartment out. Hold this compartment in this extended position and PUSH the slide handle in until it releases the chrome latch, then PULL the slide out. Film septums have springs under them and will pop up. When loading the septums, keep the film notch over the notch at the open edge of the septum.

Before putting the septum back into the compartment, be sure that the counter slide, by the felt strip, has been pulled back out of the way, into the end of the film compartment.

**CAUTION:** When the holder is open for loading, note that slight pressure on the button on the underside of the film compartment will release the automatic exposure counter slide. If the holder is laid on a flat bench, no difficulty will be encountered; otherwise, it will be necessary to make sure that this slide does not extend into the septum chamber before attempting to insert the septums -- failure to do so may result in jammed and bent septums.

When loading septums in the film compartment use the thumb and finger, holding them to act as a channel, guiding the septums down into place. All six septums must be in the compartment in order to operate the counting mechanism.

## 3. INSPECTION and TROUBLES

Many troubles encountered by the repairman will be very obvious, while others will not be too apparent. The following table of potential troubles, causes and remedies is supplied so that difficulties may be promptly recognized and proper steps taken to overcome them. Before disassembly check for loose or missing screws and sliding surfaces that are binding because of lack of lubrication.

TROUBLE	CAUSE	REMEDY
<p>Drawer binds.</p> <p>Drawer pulls out.</p> <p>Septums bent.</p> <p>Light leak.</p>	<p>Lack of lubrication on edges.</p> <p>Missing drawer stop screws - screws work loose through vibration.</p> <p>Improper loading or handling of septums.</p> <p>Cutoff assemblies damaged in disassembly.</p>	<p>Apply paraffin.</p> <p>Replace parts - seal screws in place with Glyptol or lacquer.</p> <p>Replace septums.</p> <p>Replace damaged cutoffs.</p>
<p>Counter dial does not work.</p> <p>Counter dial does not advance when septum is changed -- jumps back and forth.</p>	<p>Less than six septums.</p> <p>Missing septum stop.</p> <p>Missing counter slide.</p> <p>Broken counter slide.</p> <p>Detent spring broken or missing.</p> <p>Detent missing.</p> <p>Detent spring unhooked.</p> <p>Slide stop spring weak, broken or missing.</p>	<p>Add missing septums.</p> <p>Replace.</p> <p>Replace.</p> <p>Replace.</p> <p>Replace spring.</p> <p>Replace detent.</p> <p>Hook spring.</p> <p>Replace spring.</p>
<p>Red dot does not appear when slide is withdrawn.</p> <p>Red dot does not disappear when drawer is operated.</p>	<p>Broken counter slide spring.</p> <p>Septum does not move forward.</p> <p>Missing septum stop.</p> <p>Less than six septums.</p>	<p>Replace spring.</p> <p>Replace any bent or damaged septums</p> <p>Replace with new stop.</p> <p>Add missing septums.</p>
<p>Drawer latch does not operate but latch lever does.</p> <p>Neither drawer latch lever nor drawer latch operates.</p>	<p>Drawer latch spring broken.</p> <p>Drawer latch spring unhooked.</p> <p>Drawer latch spring broken or unhooked and detent spring broken or unhooked.</p>	<p>Replace spring.</p> <p>Rehook spring.</p> <p>Check and replace springs if necessary.</p>

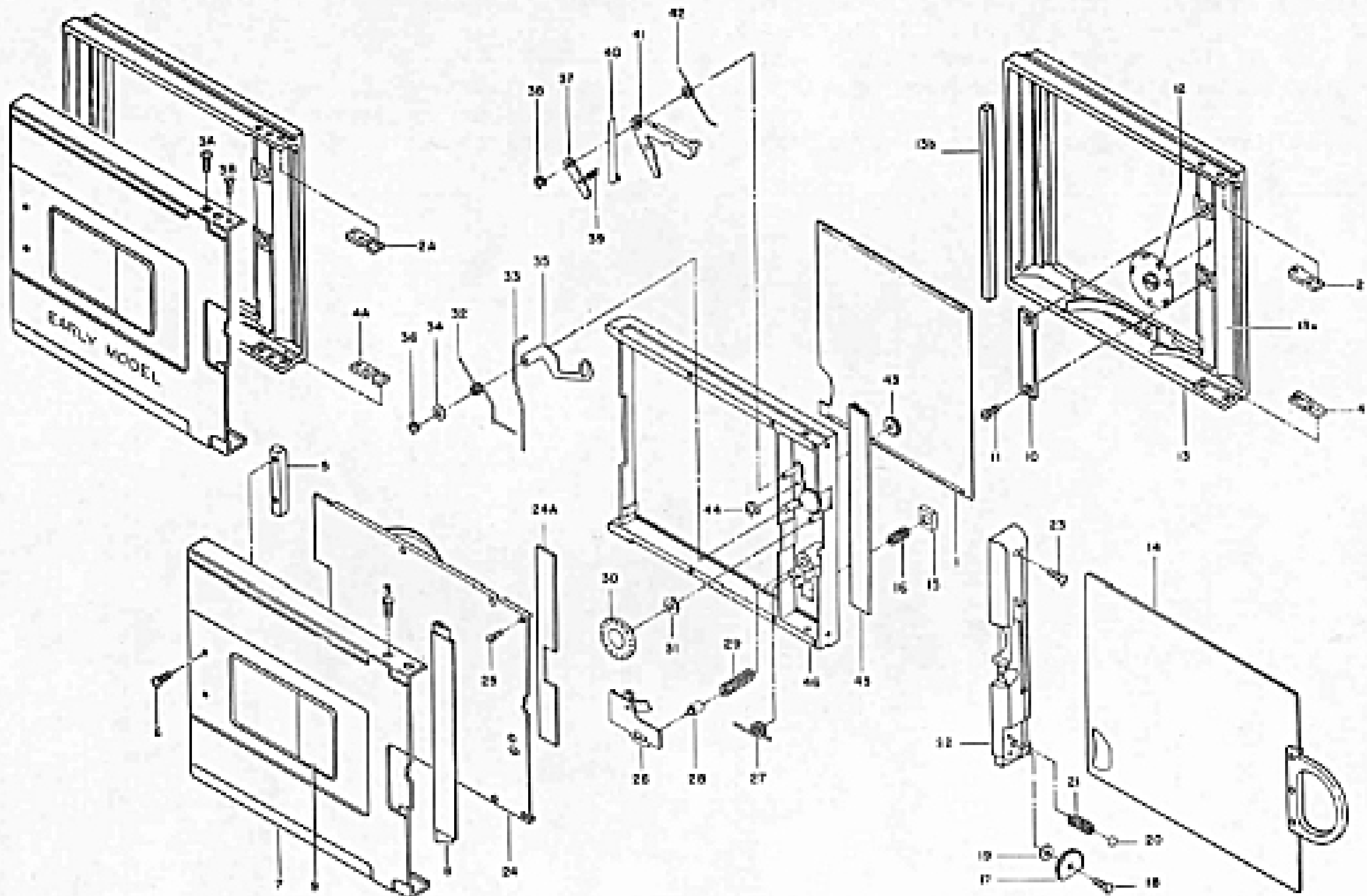

Figure 1. Grafmatic 45 (Exploded View)

**4. DISASSEMBLY**

- a. Remove film septums (1).
- b. Remove two drawer stop plates (2 and 4) by removing screws (3). Remove drawer from the Grafmatic by pulling straight out.  
  
**CAUTION:** The slide (14) must be all the way in when drawer is removed or the cutoff assembly (13a) will be damaged.
- c. Remove septum stop (5) by removing two screws (6).
- d. Slide the cover (7) from the case assembly (13).  
  
**CAUTION:** Insert a sheet of heavy paper or film holder slide between the cover and the case assembly before removing the cover to prevent damage to the cutoff assembly (8).
- e. If necessary, remove the cutoff assembly (8) and data panel (9) from cover (7).
- f. Remove dial assembly retainer (10) by removing two screws (11) and remove film dial assembly (12).

- g. If necessary, remove cutoff assembly (13a) and felt seal (13b) from case assembly (13).
- h. Remove dark slide (14) by using a stop depressing plate (make plate from brass shim stock 0.006 in. thick by 1-1/2 inch by 4 inches) inserted to the end of the dark slide, between the half withdrawn dark slide and the drawer. Pull the dark slide from the drawer and remove the slide stop (15) and spring (16).
- i. Remove drawer locking disc (17) by removing one screw (18). Remove washer (19), ball (20) and locking disc spring (21).
- j. Remove drawer plate (22) by removing one screw (23).
- k. Remove cover assembly (24) by removing six screws (25). If necessary, remove felt seal (24a).
- l. Remove counter slide assembly (26), counter slide spring (27), slide stop (28) and slide stop spring (29).
- m. Remove counter dial (30) and gear (31).
- n. Unhook spring (32) from notch on lock bar (33). Remove washer (34), lock lever spring (32), lock bar (33) and lock lever (35) secured by retaining ring (36).

o. Unhook detent spring (39) from the latch lever (41) and remove detent (37) by removing retaining ring (38). Remove detent spring (39) from detent, unhook latch spring (42) from notch in latch (40) and remove latch (40), latch lever (41) and latch spring (42).

p. Remove magnet gear assembly (43) by remov-

ing retaining ring (44). If necessary, remove cutoff assembly (45) from drawer assembly (46).

### 5. CLEANING

Reassembly drawer after thoroughly cleaning; use trichlorethylene to remove all old lubricants, toluol and acetone to remove old EC-784 cement.

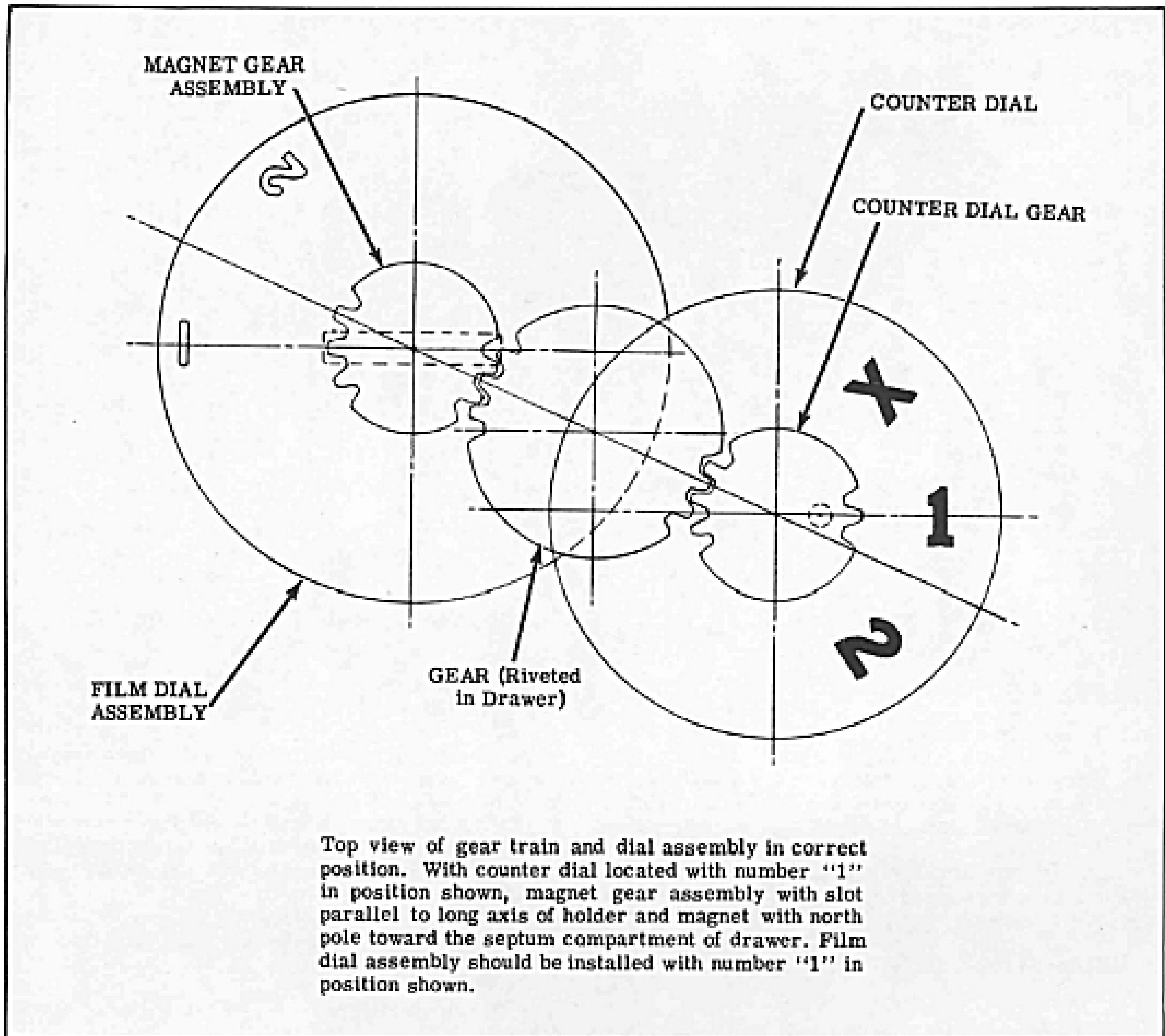

### 6. REASSEMBLY

a. Reassemble cutoff assembly (45) to drawer assembly (46) using 1/2 inch tape.

b. Apply small amount of grease, MIL-G-3278, to shaft of magnet gear assembly (43) and assemble to the drawer so that the magnet gear assembly is perpendicular to adjacent cross-piece of drawer, when magnet gear meshes with gear riveted to drawer. Secure in place with retaining ring (44).

**NOTE:** It is very important that the magnet gear be assembled correctly to be in synchronization with the counter dial. Check magnet polarity with a compass whenever the magnet gear assembly is removed from the drawer or when a replacement magnet gear assembly is being installed.

c. Apply small amount of grease, MIL-G-3278, to brass studs riveted in drawer and assemble latch spring (42), latch lever (41) and latch (40) hooking spring under latch lever and into notch of latch. Hook detent

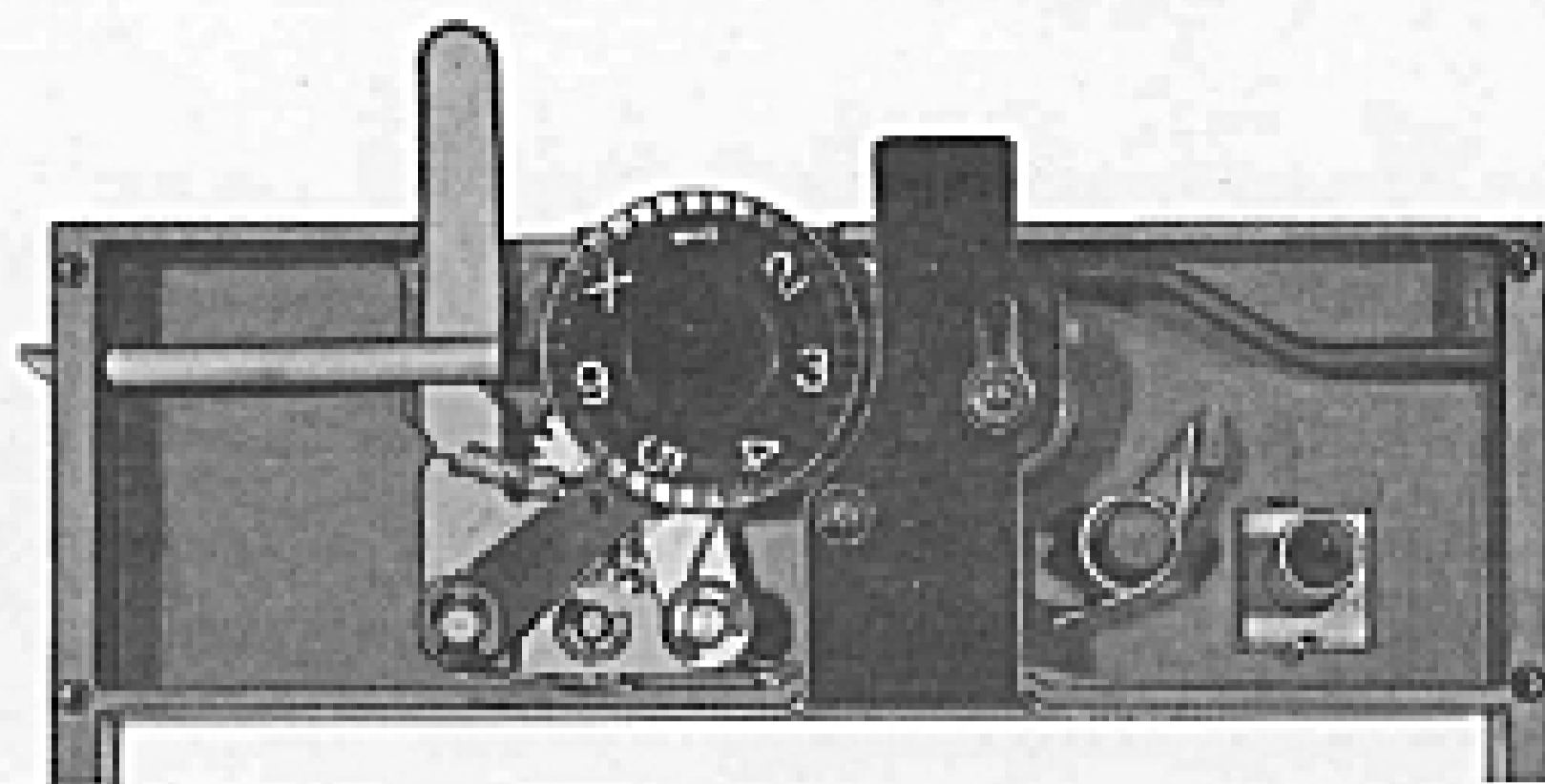

Figure 2. Counter Mechanism (Current Model)

spring (39) to detent (37) and secure in place with retaining ring (38). Hook square end of detent spring in notch on side of latch lever (41).

d. Assemble lock lever (35), lock bar (33), lock lever spring (32), washer (34) and secure with retaining ring (36). Hook lock lever spring (32) under lock lever (35) and into notch on end of lock bar (33).

e. Apply Glyptol to counter dial (30) and assemble gear (31), making sure identification mark is on the outside and in line with the number "1" on counter dial.

NOTE: Assemble counter dial so that the number "1" is in location and the gear on the end of the counter dial meshes with the gear riveted in the drawer. See figure on page 4.

f. Assemble the slide stop spring (29) and slide stop (28).

g. Apply a small amount of grease, MIL-G-3278, to hole in lever of counter slide assembly (26). Assemble the counter slide spring (27) on boss on drawer and insert long end of spring through hole of lever of counter slide assembly. Assemble to drawer, keeping the lever to the side and under flange of the counter dial (30), so that the end of the lever engages the counter dial notches.

h. Recement felt seal (24a) to drawer cover assembly (24) using EC-784.

i. Insert a drop of Glyptol, lacquer or shellac into each of the six holes in the drawer and assemble the cover assembly (24) using six screws (25).

j. Assemble the drawer plate (22) and secure with one screw (23).

k. Assemble locking disc spring (21), ball (20) to drawer plate and assemble washer (19), locking disc (17) and secure with screw (18).

l. Lubricate side edges of dark slide (14) with paraffin. Insert slide until it just covers cutoff as-

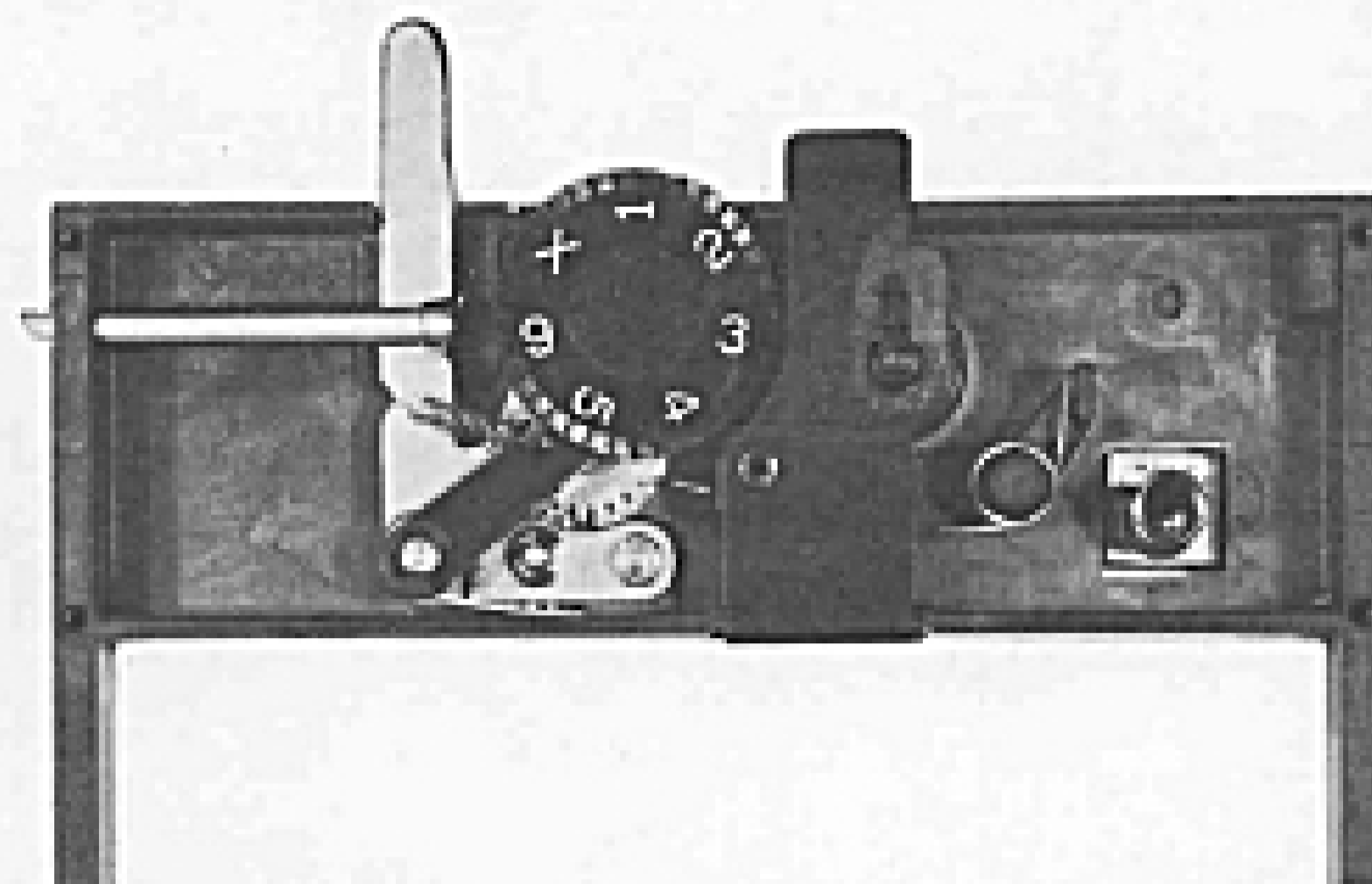

Figure 2A. Counter Mechanism (Early Model)

sembly (45). Assemble stop spring (16) to slide stop (15) and insert into position in the drawer so that the punched lip is facing the slide. Depress stop into hole in drawer until it clears the dark slide. Push dark slide (14) inward until stop drops into notch of slide. Operate dark slide several times to insure correct assembly.

m. If felt seal (13b) has been removed, recement with EC-784 to case assembly (13) and assemble cutoff assembly (13a) using 1/2 inch tape.

n. Assemble film dial assembly (12) and dial retainer (10) to case assembly (13) and secure in place using two screws (11).

o. If necessary, recement the data panel (9), using EC-784, to cover (7) and assemble cutoff assembly (8) using 1/2 inch tape. Assemble septum stop (5) using two screws (6).

p. Assemble cover (7) and case assembly (13). Slide the dark slide all the way into the drawer and insert the drawer complete into the assembled case and cover.

q. Turn magazine on edge, with front of magazine away from the repairman, pull the drawer out half way, assemble drawer plate stops (4 and 2) and apply a drop of Glyptol, lacquer or shellac into each screw hole and secure in place with screws (3).

NOTE: After assembly wipe off any excess Glyptol, lacquer or shellac from edge of drawer.

r. Insert septums (1) and check correct synchronization between counter and film exposure dial, correct operation of drawer latch, drawer latch lever, and proper cycling of septums and correct operation of counter mechanism. Check the drawer lock to see if the drawer locks in place after the sixth septum has been rotated and the "X" on counter dial will be in position.

CAUTION: To prevent damage to septums when Grafmatic is loaded make sure that the counter slide is pushed back out of the way, into the end of the film compartment.

## LUBRICANTS, CLEANING SOLVENTS, ADHESIVES

Materials are specified for general reference by U.S. Government Specifications. If the recommended material cannot be located, local suppliers can advise a substitute that meets a specification number.

Compound	U.S. Government Specification	Manufacturer	Use or Application
<b><u>LUBRICANTS</u></b>			
Neolube	Not assigned	Huron Industries Huron, Michigan	Drawer dark slide channels Counter slide Drawer stop plates Holes in drawer lock disc for steel ball
Dow No. 44 light consistency silicone grease or Texaco Unitemp	-----  MIL-G-3278	Dow Corning Corp. Midland, Michigan  Texas, Co.	Hole in drawer for latch Hole in drawer for bar Hole in lever of counter slide assembly Brass studs of drawer Shaft of magnet gear assy.
Paraffin	VV-P-121a	Socony Vacuum New York, N. Y.	Edges of drawer Edges of dark slide
<b><u>SOLVENTS</u></b>			
Trichlorethylene (2nd choice - Carbon Tetrachloride)	AN-T-37a	Eastman Kodak Co. Rochester, N. Y. Organic Chemicals Div.	Cleaning metal parts of oil and grease
Toluol or Acetone	AN-T-541  O-A-51b	Eastman Kodak Co. Rochester, N. Y.	Removing old EC-784 Cement
<b><u>ADHESIVES</u></b>			
Adhesive EC-784	MIL-A-140A	Minnesota Mining & Mfg. Co. Detroit, Michigan	Felt seal to cover Felt seal to case assembly Data panel to cover
Glyptol Cement #1276	-----	General Electric Co. Pittsfield, Mass.	Threads of machine screws Also used to hold magnets in position



## PARTS LIST

The Group Assembly Parts Lists are listed in disassembly order. The list divides the components into major assemblies, their subassemblies and parts. By the use of indented columns, the relationship of the assemblies to the subassemblies and parts is obtained.

The column titled "Figure and Index No." contains the index number in disassembly order of the items illustrated. Do not use the figure or index number in correspondence--specify the catalog or part number and name. Finish should also be included where specified.

The column titled "nomenclature" (including numbered columns) lists item nomenclature on the Graflex drawing. The assembly in the column marked "3" will be a component of the first assembly which preceded it in the column marked "2" etc. The code "NP" will indicate that this part is "not procurable" and that the "next higher assembly" (NHA) should be ordered. The code "AR" is used for bulk items when an indefinite amount may or may not be used "as required. The code "LP" is used when an item may be "locally purchased."

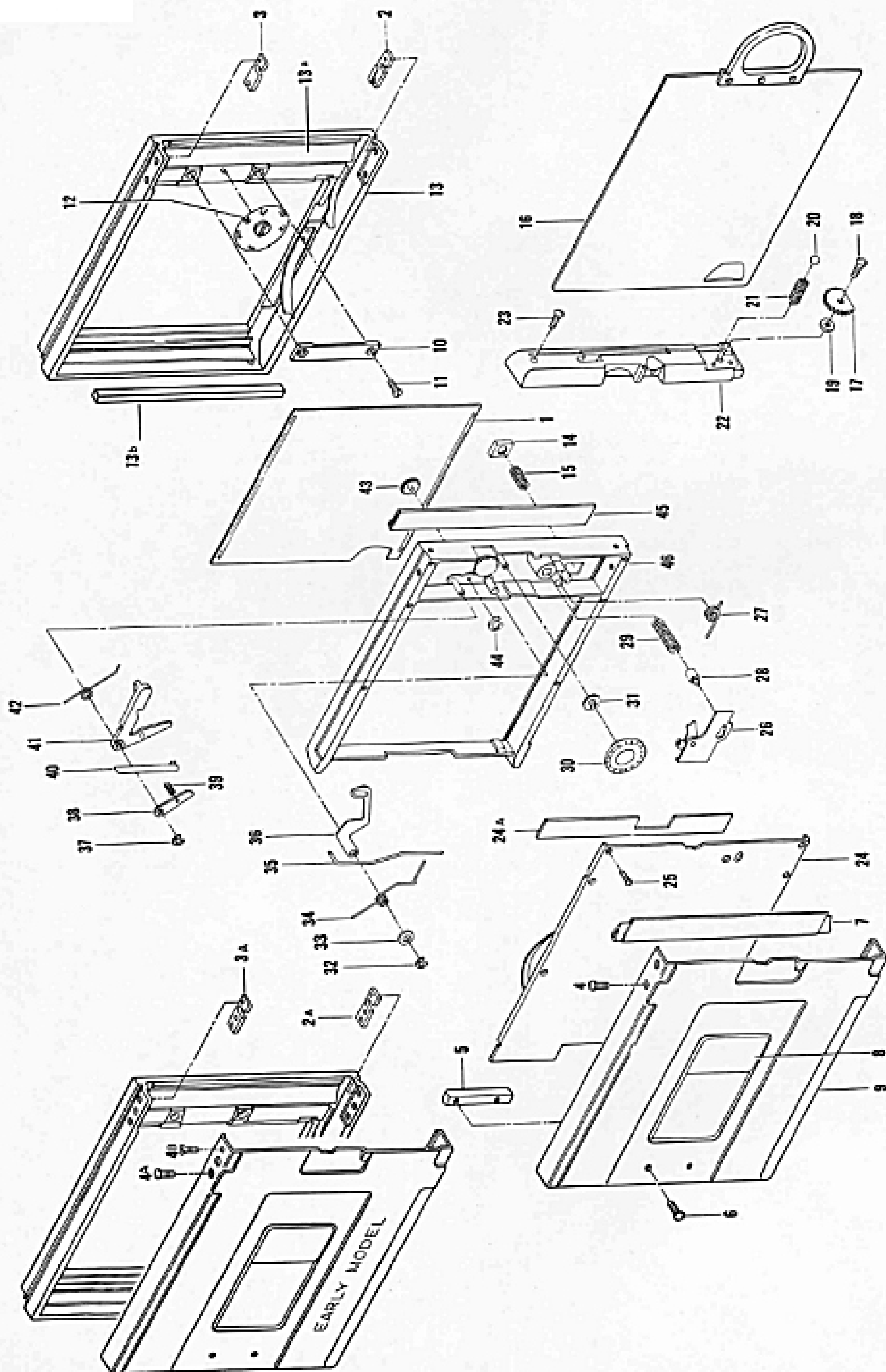

Figure 1. GRAFMATIC 45 (Exploded View)

Figure and Index No.	Part No.	1	2	3	4	5	Nomenclature	Qty.
1-	32352G1						MAGAZINE COMPLETE - 4 x 5 GRAPHIC (Cat. 1268) . . . . .	1
	32352G2						MAGAZINE COMPLETE - 4 x 5 GRAFLEX (Cat. 1168). . . . .	DISCONTINUED
-1	32385P1	.	.	.	.	.	Septum - Film (Cat. 1588 for 1 ea. or Cat. 1580 for 6 ea.) .	6
-2	32381P1	.	.	.	.	.	Plate - Lower Stop (CURRENT) . . . . .	1
-2A	32359G1	.	.	.	.	.	Plate Assembly - Lower (EARLY) . . . . .	1
-3	32381P2	.	.	.	.	.	Plate - Upper (CURRENT) . . . . .	1
-3A	32359G2	.	.	.	.	.	Plate Assembly - Upper . . . . .	1
	Attaching Parts							
-4	30749P3	.	.	.	.	.	Screw - Machine (special) CURRENT . . . . .	4
-4A	31843P2	.	.	.	.	.	Screw - Machine (special) EARLY . . . . .	4
-4B	104-1-3L	.	.	.	.	.	Screw - Machine (EARLY) No. 1-64 x 3/16 oval hd. . . . .	2
	----***----							
-5	31841P1	.	.	.	.	.	Stop - Septum . . . . .	1
	Attaching Parts							
-6	30921-5	.	.	.	.	.	Screw - Self Threading, No. 2 x 3/16 pan hd., black oxide and black enamel L-40 . . . . .	2 (specify finish when ordering)
	----***----							
-7	31770G6	.	.	.	.	.	Cutoff Assembly (3 dimples) . . . . .	1
		.	.	.	.	.	Tape (cutoff) . . . . .	LP
-8	32383	.	.	.	.	.	Panel - Data . . . . .	1
-9	32358P3	.	.	.	.	.	Cover - Graphic (CURRENT) . . . . .	1
	32358P1	.	.	.	.	.	Cover - Graphic (EARLY) no longer available - replace with 32358P3 and indices 2, 3&4 . . . . .	Ref.
	32358P4	.	.	.	.	.	Cover - Graflex (CURRENT) . . . . .	1
	32358P2	.	.	.	.	.	Cover - Graflex (EARLY) no longer available - replace with 32358P3 and indices 2, 3&4 . . . . .	Ref.
-10	32375P1	.	.	.	.	.	Retainer - Dial Assembly . . . . .	1
	Attaching Parts							
-11	124-2-3L	.	.	.	.	.	Screw - Thread Forming, No. 2 x 3/16 flat hd. (was p/n 30921-P23L) . . . . .	2
	----***----							
-12	32372G1	.	.	.	.	.	Dial Assembly . . . . .	1
-13	32353G4	.	.	.	.	.	Case Assembly - Second (Graphic) . . . . .	1
	32353G5	.	.	.	.	.	Case Assembly - Second (Graflex) . . . . .	1
-13a	31770G4	.	.	.	.	.	Cutoff Assembly (1 dimple) . . . . .	1
		.	.	.	.	.	Tape (cutoff) . . . . .	LP
-13b	32356P1	.	.	.	.	.	Seal . . . . .	1
	32357	.	.	.	.	.	Pin - Dial . . . . .	NP
		.	.	.	.	.	Case Assembly - First (Graphic) . . . . .	NP
		.	.	.	.	.	Case Assembly - First (Graflex) . . . . .	NP
	175-3-8K	.	.	.	.	.	Rivet (spring was p/n 30363-P26K . . . . .	6
	32386P1	.	.	.	.	.	Spring - Left (short) . . . . .	1
	32386P2	.	.	.	.	.	Spring - Right (short) . . . . .	1
	32355P1	.	.	.	.	.	Spring - Left (long) . . . . .	1
	32355P2	.	.	.	.	.	Spring - Right (long) . . . . .	1
		.	.	.	.	.	Case - Graphic . . . . .	NP
		.	.	.	.	.	Case - Graflex . . . . .	NP
-14	33771P1	.	.	.	.	.	Stop - Dark Slide . . . . .	1
-15	33772	.	.	.	.	.	Spring - Stop . . . . .	1
	33838G1	.	.	.	.	.	Drawer Complete . . . . .	1
-16	31767G2	.	.	.	.	.	Slide Assembly - Dark . . . . .	1
	176-3-9K	.	.	.	.	.	Rivet (handle) was 30363-P14K . . . . .	3
	31769P1	.	.	.	.	.	Handle - Slide . . . . .	1
		.	.	.	.	.	Slide . . . . .	NP
-17	32387	.	.	.	.	.	Disc - Drawer Lock . . . . .	1
	Attaching Part							
-18	32388P1	.	.	.	.	.	Screw - Machine (special) . . . . .	1
	----***----							
-19	33500-52	.	.	.	.	.	Washer - Flat, 0.203 x 0.094 x 0.0080 . . . . .	1
-20	300-4	.	.	.	.	.	Ball - Steel (0.09375 dia) . . . . .	1
-21	32389	.	.	.	.	.	Spring - Locking Disc . . . . .	1

Figure and Index No.	Part No.	1	2	3	4	5	Nomenclature	Qty.
1-22	32384P1	.	.	.	.	.	Plate - Drawer . . . . .	1
	Attaching Part							
-23	106B2-6K	.	.	.	.	.	Screw - Machine, No. 2-56 x 3/8 round hd . . . . .	1
	---***---							
-24	31771G2	.	.	.	.	.	Cover Assembly . . . . .	1
-24a	32392P1	.	.	.	.	.	Seal - Felt . . . . .	1
	176-3-6K	.	.	.	.	.	Rivet (spring) was p/n 30363-P5 . . . . .	4
	31773	.	.	.	.	.	Spring - Drawer . . . . .	2
		.	.	.	.	.	Cover - Drawer . . . . .	NP
	Attaching Parts							
-25	31908	.	.	.	.	.	Screw - Machine (special) . . . . .	6
	---***---							
-26	31855G2	.	.	.	.	.	Slide Assembly - Counter . . . . .	1
-27	31859	.	.	.	.	.	Spring - Counter Slide . . . . .	1
-28	31860	.	.	.	.	.	Stop - Slide . . . . .	1
-29	30841	.	.	.	.	.	Spring - Slide Stop . . . . .	1
-30	32379P1	.	.	.	.	.	Starwheel - Counter . . . . .	1
-31	32380P1	.	.	.	.	.	Gear Starwheel . . . . .	1
-32	251-7	.	.	.	.	.	Ring - Retaining . . . . .	1
-33	30473-72	.	.	.	.	.	Washer - Flat, 0.250 x 0.128 x 0.005 . . . . .	1
-34	32335P1	.	.	.	.	.	Spring - Lock Lever . . . . .	1
-35	32423P1	.	.	.	.	.	Bar - Lock . . . . .	1
-36	32277P1	.	.	.	.	.	Lever - Lock . . . . .	1
-37	251-7	.	.	.	.	.	Ring - Retaining . . . . .	1
-38	31852P1	.	.	.	.	.	Detent . . . . .	1
-39	31853	.	.	.	.	.	Spring - Detent . . . . .	1
-40	32376P1	.	.	.	.	.	Latch . . . . .	1
-41	32377P1	.	.	.	.	.	Lever - Latch . . . . .	1
-42	31848	.	.	.	.	.	Spring - Latch . . . . .	1
-43	32352G1M	.	.	.	.	.	Magnet Gear Assembly . . . . .	1
	Attaching Part							
-44	251-5	.	.	.	.	.	Ring - Retaining . . . . .	1
	---***---							
-45	31770G5	.	.	.	.	.	Cutoff Assembly (2 dimples) . . . . .	1
		.	.	.	.	.	Tape (cutoff) . . . . .	LP
-46	32361G1	.	.	.	.	.	Drawer Assembly . . . . .	1