

# H A S S E L B L A D

## Service Manual

# 503CW

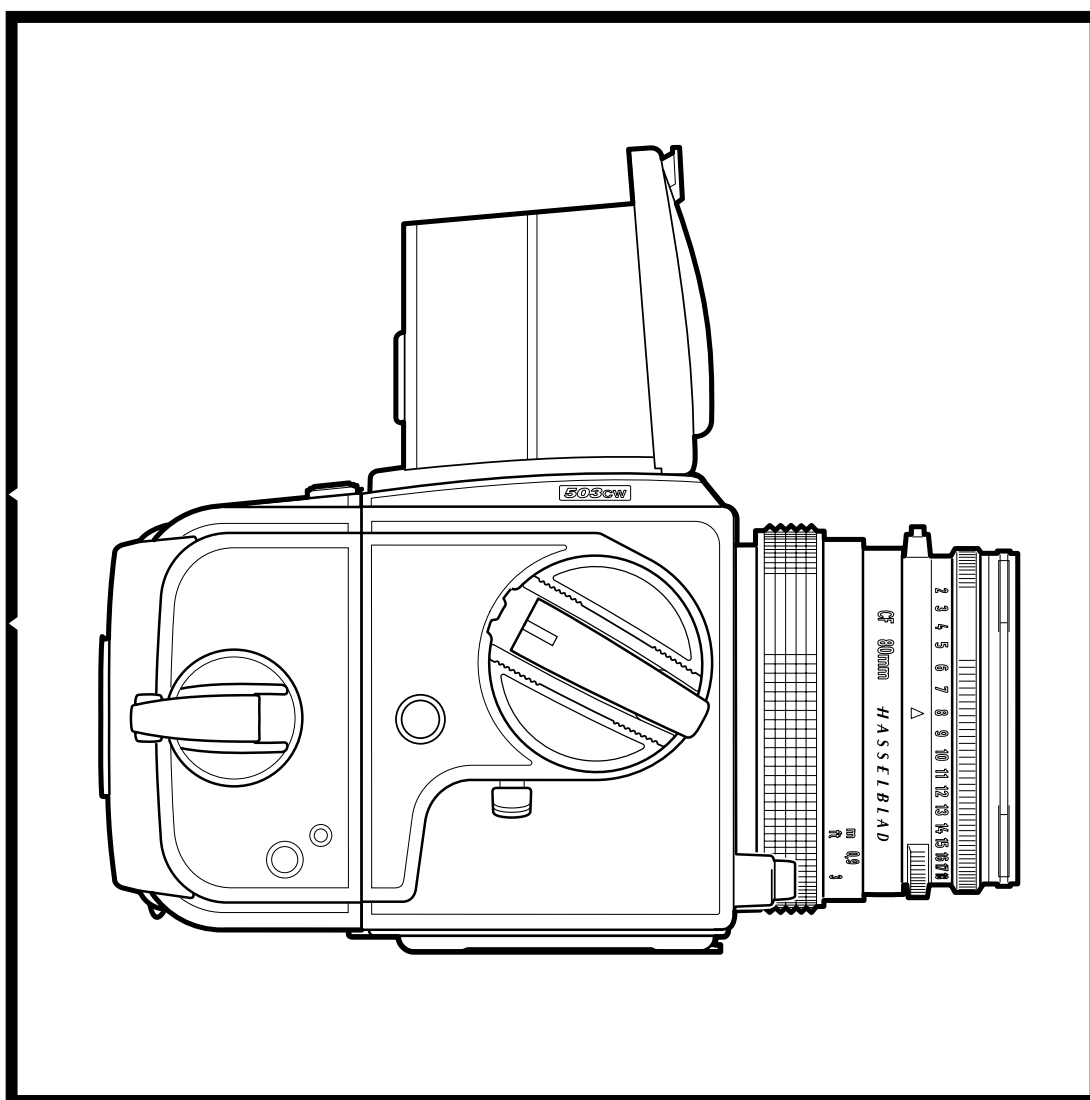

October 1996

**Victor Hasselblad AB**

**Göteborg Sweden**

Copyright © 1998 by Victor Hasselblad AB. All rights reserved. No parts of this material may be reproduced, stored in retrieval system or transmitted, in any form or by any means, electronic, mechanical, photocopy, recording, or otherwise, without the prior written permission of the Company.

**Camera body 503CW**

---

- 1. General**

---
  - 2. Tools**

---
  - 3. Disassembly**

---
  - 4. Reassembly**

---
  - 5. Adjustment, final assembly and calibration of the flash meter**

---
  - 6. Sub-assembly: Front bayonet plate and auxiliary shutter with mirror**

---
  - 7. Exploded view: Shell**

---
  - 8. Exploded view: Gear housing**

---
  - 9. Exploded view: Mechanism plate**

---
  - 10. Exploded view: Auxiliary shutter and mirror assembly**

---
  - 11. Exploded view: Front bayonet plate**

---
  - 12. Exploded view: Right hand wall**

---
  - 13. Exploded view: Left hand wall and electronics**

---
  - 14. Exploded view: Winding crank**

---
  - 15. Camera body 501C**

---
  - 16. Camera body 503CXi**

---
  - 17. Camera body 503CX**

---
  - 18. Camera body 500C/M (Classic)**

---
  - 19. Camera body 501CM**

---
- 
- 
- 
-

---

**503CW - 501C - 503CX/CXi - 500C/M - 501CM****1.**

---

**17/93** Fitted with wrong spacers - 503C/M and 503CX

---

**20/93** Flash metering circuit redesigned - 503CX

---

**04/94** New camera - 501C

---

**05/94** Exploded views and spare part specifications - 501C and 503CXi

---

**06/94** Spare part No. changed - 500C/M and 503CX

---

**12/94** Pin fitted in bayonet plate - 501C

---

**04/95** Tripod foot modified - 501C and 503CXi

---

**09/95** New tool - 503CXi

---

**10/95** Updated pages - 503CXi

---

**02/96** Signal arm shortened - 501C and 503CXi

---

**12/96** Tripod foot adapter/kits

---

**14/96** New Service Manual - 503CW

---

**14/97** New camera body - 501CM

---

**15/97** Modifications - 501C and 503CW

---

**28/97** Camera body in black finish - 501CM

---

**12/98** New film speed range - 503CW

---

**02/99** Discontinued parts - 501C, 503CXi, 503CX and 500C/M

---

**10/99** Stray-light - 503CW, 501CM, 501C, 503CX/CXi and 500C/M

---

**01/00** New CD-ROM - Version 1.2

---

**08/00** Washer added in the gear box - 501CM and 503CW

---

**09/00** New CD-ROM - Version 1.3

---

**14/00** Discontinued parts - 500 series cameras

---

**01/01** Modified magazine hook - 501CM and 503CW



---

## Camera body 503CW

## General description

<b>Camera type:</b>	Single lens reflex camera with 6 x 6 (2 1/4 x 2 1/4 in) max. film size. Interchangeable lenses, film magazines, viewfinders and focusing screens.
<b>Design:</b>	Mechanical, with an aluminium alloy camera body shell cast in one piece.
<b>Viewfinders:</b>	Folding focusing hood interchangeable with reflex viewfinder, prism viewfinders with or without built-in exposure meter or magnifying hoods.
<b>Film advance:</b>	Manual advance or motor driven with Winder CW. Simultaneous shutter cocking. Winder CW winding time: 1.05 sec, approx. 0.8 frames/sec in continuous mode.
<b>Flash control:</b>	TTL/OTF-metering. ISO 16 - 1000 with flash adaptors SCA390 or SCA590 for connection with flash units from the SCA300 or SCA500 systems respectively. Metering area within 40 mm diameter in the centre of the image area. <b>Note! From camera serial No. 19ER18271 the ISO range is changed to 64 - 4000.</b>
<b>Tripod coupling:</b>	1/4 in and 3/8 in socket threads and base plate for quick coupling attachments.
<b>Lens mount:</b>	Hasselblad bayonet mount for CF and C lenses.
<b>Focusing screen:</b>	Hasselblad Acute-Matte D* focusing screen. Sales code No. 42204.
<b>External dimensions:</b>	91L x 114W x 110H (3 9/16 x 4 1/2 x 4 11/32 in).
<b>Weight:</b>	610 g.

## Camera body 503CW

## Camera release sequence

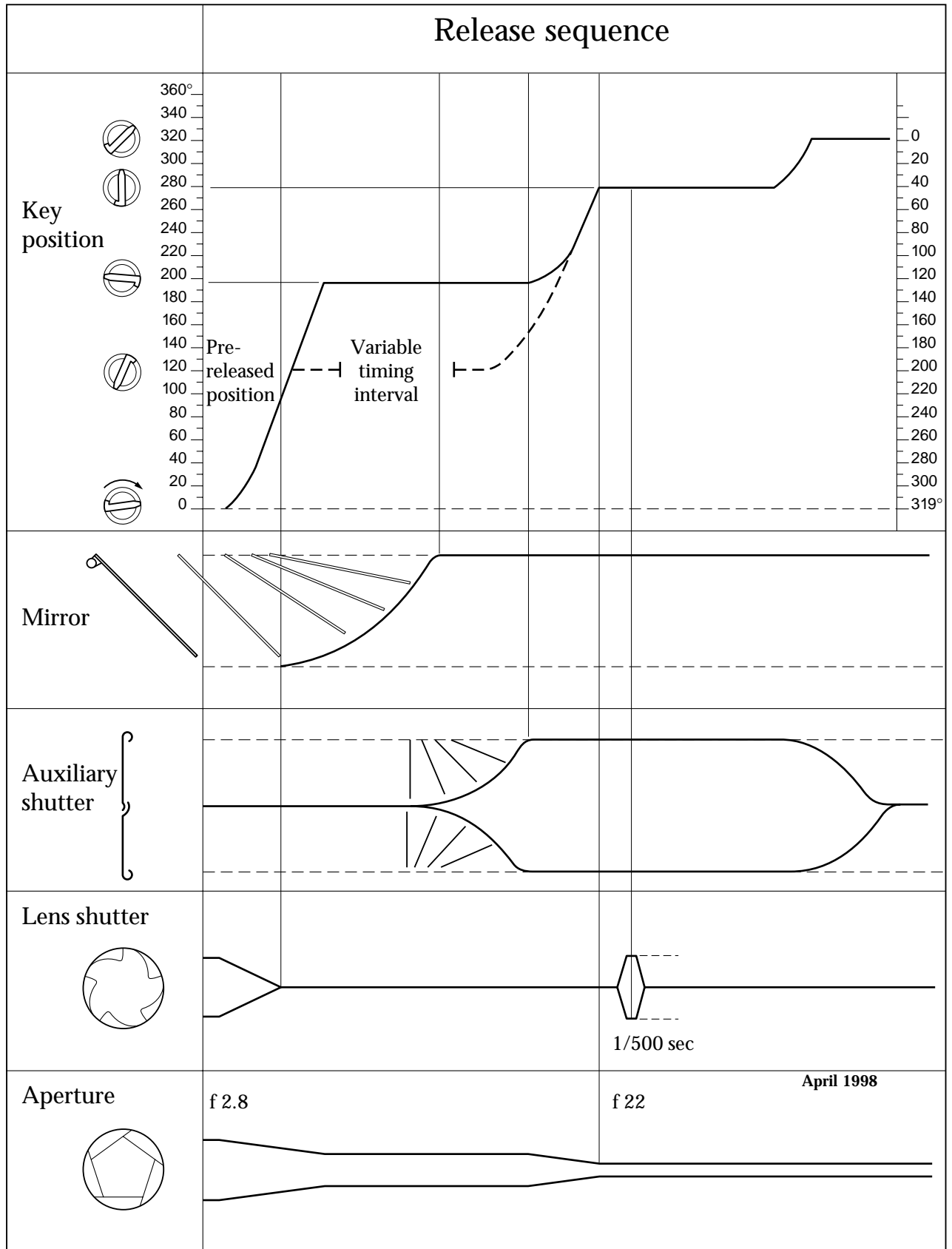

**Camera body 503CW****Tools**

<b>Tool No.</b>	<b>Description</b>	<b>Used for</b>
V-2200	Bender	Signal arm adjustment
V-2201	Bender	Mirror arm adjustment
V-2202	Bender	S-arm adjustment
V-2203	Bender	Release arm adjustment (aux. shutter)
V-2205	Bender	Supporting tool when using V-2201
V-2206	Winding knob	Substitutes regular winding crank during repair work
V-2211	Pin driver	Fitting the locating pin in the front plate and the front gear bracket
V-2224	Bender	Release arm adjustment
V-2229	Focal length gauge	Adjustment of the focal length, mirror 45° angle and focusing screen
V-2236	Microscope	Focusing screen adjustment
V-2354	Exposure gauge	Release sequence control
V-4151/52	Focusing tester	Focusing screen adjustment
V-4704	Key	Focusing screen adjustment
V-4705	Focusing screen adapter	Focusing screen adjustment

**Camera body 503CW****Tools**

<b>Tool No.</b>	<b>Description</b>	<b>Used for</b>
V-5423	Riveting jig	Replacement of aux. shutter flaps
V-5942	Exp. gauge	Release mechanism adjustment
902474	Test box ELX/CX	Calibration of the TTL flash meter
902658 (V-2075)	Key angle gauge	Adjustment of the front key angle
904644	Bayonet plate	Stop lever adjustment
970600	Service Test System	Calibration of the TTL flash meter
905020	Screwdriver	Screws in the mirror box



## Camera body 503CW

## Disassembly

### Camera shell

Remove the lens, film magazine, view finder, focusing screen and winding knob.

Remove the screw (830060), coupling (22767) and washer (22799).

Remove the leather (13374), shim (22473), screw (822701) and ISO selector knob (22495).  
Do not damage the sliding contacts.

Remove the cap (22470) from the chassis connector and peel back the leather covering two screws (823335). Remove these screws and firmly push the chassis connector into the body of the camera.

Remove the tripod foot (30763) held by six screws (829755). Remove the two rear screws (829755) and the two front screws (820781).

Fig. 1.

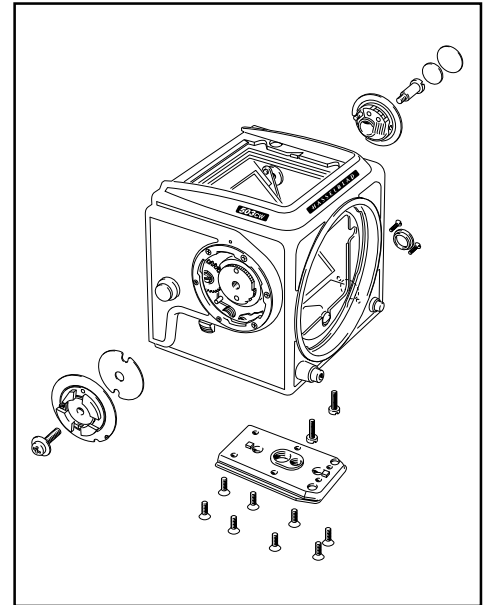

Fig. 1

The chassis can now be separated from the camera shell. Ensure that the lens release button (13139), release button (22759), buffer (22367), teflon cone (103773) and distance washers (810620) are not dislodged from the camera shell and lost.

Fig. 2.

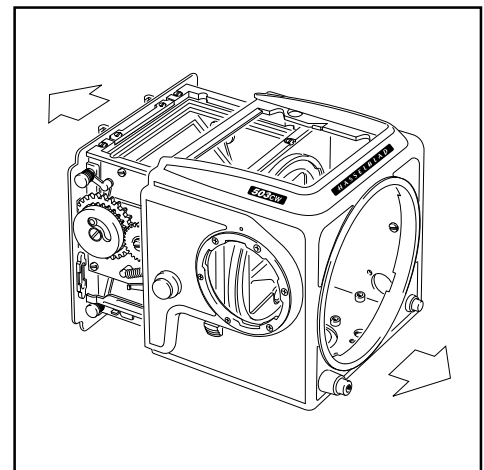

Fig. 2

Operate the S-release on the camera by pressing the S-arm (21167) towards the stop. Remove the front gear cover (22876). Do not remove the side cover (22813) unless it is absolutely necessary.

The side cover is held in position by the spring (30775) secured with two screws (829425) and double sided tape.

**Note! If removed, a new cover must be used when the camera is reassembled.**

## Camera body 503CW

## Disassembly

### Circuit board (22575) \*22882

**CAUTION! When handling the circuit board a grounded bench mat and a wrist strap must be used to prevent ESD damage.**

Lift the chassis connector out of the hole in which it is seated in the left hand wall. Remove the two screws (820325) that secure the photodiode. Gently ease the photodiode through the hole in the left wall.

Remove the two screws (820011) and the grounding attachment (22453). Remove the screw (820011) and the cable holder (12453). Remove the two screws (820015) and separate the circuit board from the chassis.

Finally, remove the insulating plate (22746).

**\* Note! The circuit board (22882) is fixed to the wall by an insulating double-sided tape, screws and attachment.**

Fig. 3.

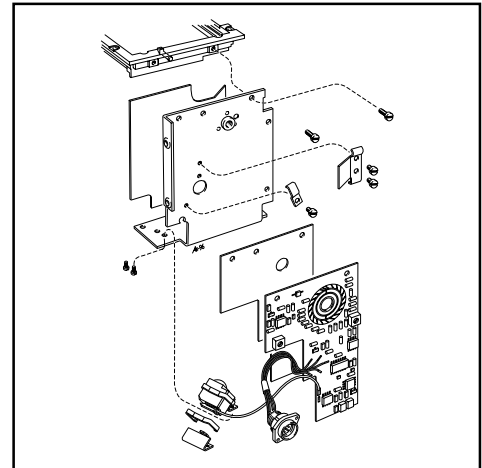

Fig. 3

### Front bayonet plate (30777)

Disconnect the spring (814512) from the push rod (22369). Remove the release bar (30375) by gently lifting it with a screwdriver so that it is freed from the front gear wheel and then easing it forward.

Remove the front bayonet plate (30777) by removing two screws (820015) in each of the right and left sides, two (821017) in the view finder screen frame and two (823655) in the bottom plate. Carefully draw the front plate forward.

Fig. 4.

**Note! The drive spring should be held when the gear wheel is released to prevent damage to the drive spring by releasing the tension too quickly.**

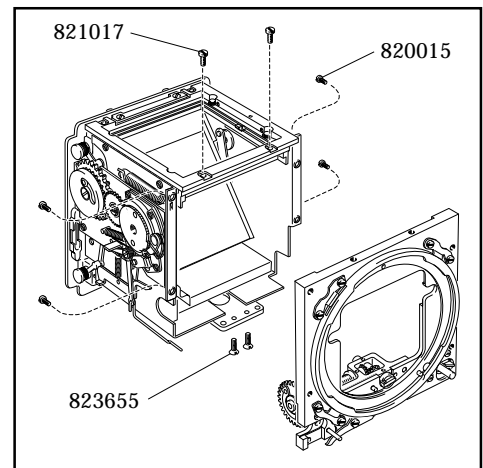

Fig. 4

### Rear plate (30300) (including auxiliary shutter)

Disconnect the arm (22781) secured to the mirror frame by a clip (817115). Remove the washer (810649) underneath the arm. Remove two screws (821017) on top of the focusing screen frame and six (820015) then partly withdraw the rear plate. When partly removed, disconnect both the upper and lower connecting rods. The rear plate can now be removed completely.

Fig. 5.

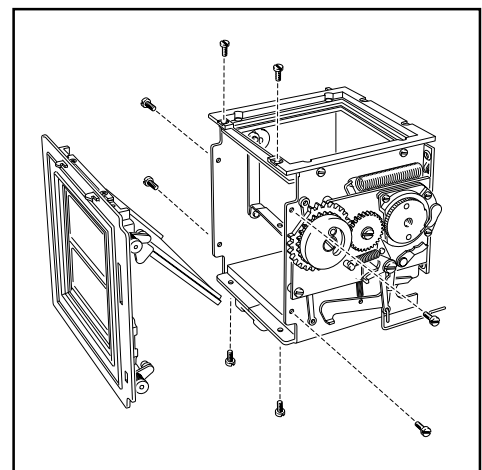

Fig. 5

## Camera body 503CW

## Disassembly

### Focusing screen frame (22812)

Remove the two remaining screws (820015) holding the focusing screen frame to the right hand wall and lift the frame off.

### Right hand wall (21095-1)

Remove (or cut) the foam plastic pad (22582) to get access to the three screws (820014). Remove the right hand wall.

### Mechanism plate (21125-1)

Remove the damping ring (22287) by first removing screw (822605) and washer (810836). Put the screw (822605) back, to keep the spring (30384) in place. Remove the screw (821631), washer (810532) and gear wheel (13112). Beneath the gear wheel remove washer (810826). Remove the mirror spring (814827).

Fig. 6.

Remove the mirror actuating lever (13362) from the rear of the right hand side wall together with the lens lock (13280).

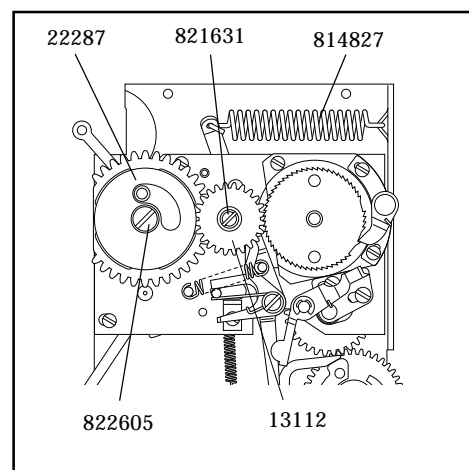

Fig. 6

Remove the following parts shown in Fig. 7.

1. Spring (814826)
2. Screw (821032)
3. Spring (816914)
4. S-arm (21167) and hub (840701)
5. Release arm (13357) including push rod (22369)
6. Stop lever (22769), clip (817119) and spring (816752)

Remove the remaining six screws, the stop angle (13432) and adjustable pawl (13170). Separate the mechanism plate from the right hand wall.

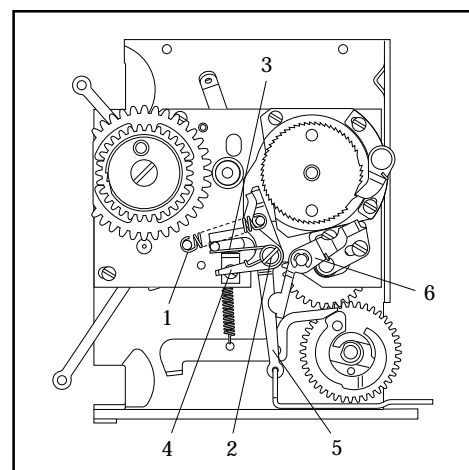

Fig. 7

## Camera body 503CW

## Disassembly

Remove the lower (13101) and the upper (13100) connecting rods and dismantle the remaining parts on the mechanism in the following order.

Fig. 8.

1. Screws (820016) 2 pcs
2. Bearing bracket (13171) and nut (13116)
3. Gear wheel (13167)
4. Screw (822605)
5. Lid (14280)
6. Gear (22699)

### Note!

**When removing the gear (22699) care should be taken to ensure that the spring (30384) does not become displaced.**

Reverse side.

Fig. 9.

10. Gear (13182)
11. Auxiliary shutter stop (22436)
12. Clip (817112) washer (810404) spring (816802)
13. Shutter bar (20912) (Note. The gear housing must be rotated)

### Gear housing (30324)

Remove the gear housing from the mechanism plate and remove the screw (821033) and the cam (22355). Separate the front and rear section of the gear housing and disassemble as follows.

Fig. 10.

1. Disconnect spring (816504)
2. Remove activating hook (20919)
3. Locking ring (810938)
4. Washer (810826)
5. Locking pin (812106)
6. Gear wheel (13169)
7. Ratchet wheel (20924)
8. Washer (810840)
9. Gear wheel (13509)

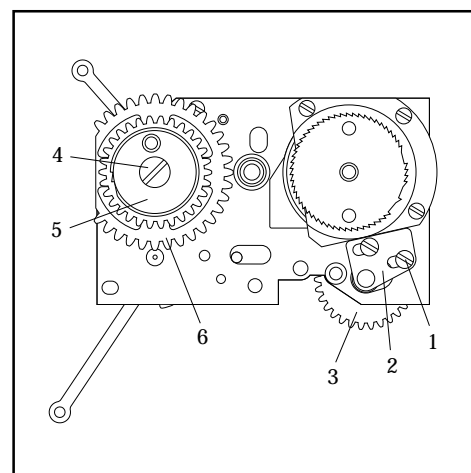

Fig. 8

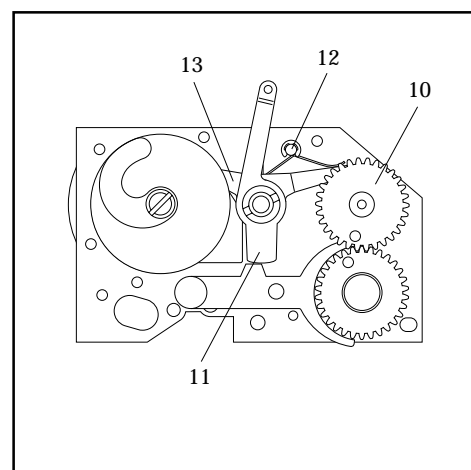

Fig. 9

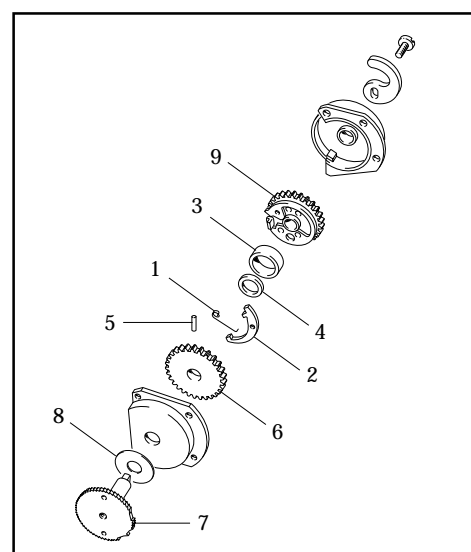

Fig. 10

## Camera body 503CW

## Reassembly

The lubricants mentioned in the text are:

Grease = Isoflex Topas L32

Oil = Isoflex PDP 48

### Gear housing (30324)

Lubricate carefully the washer (810840) with oil. Lubricate with grease and fit (incl. the above mentioned washer) the ratchet wheel (20924) into the front section of the gear housing (30304).

Lubricate with grease and fit the gear wheel (13169).

**Note. The correct relationship between the two gears before inserting the locking pin (812106) into the shaft.**

Fit the locking ring (810938) and the activating hook (20919), lubricate carefully with oil. Fit the spring (816504) and the washer (810826).

Place the stop gear (13509) into the rear section of the gear housing (13157).

Lubricate the shaft of the ratchet wheel (20924) and put the front and rear section together.

Fit the mirror cam (22355) and secure with the screw (821033).

**Note! The position of the mirror cam (22355) relative to ratchet wheel (20924).**

Fig.11.

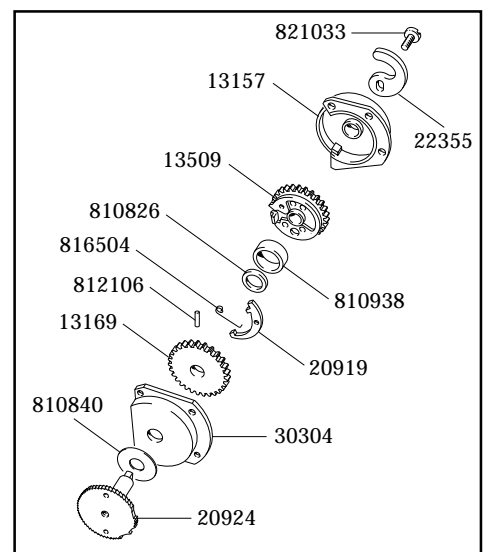

Fig. 11

### Mechanism plate (21125-1)

Ensure the auxiliary shutter release connecting rod coupling and the control gear wheel move freely (i.e. with no friction). Lubricate lightly with oil. Lubricate the gear wheel's cam with grease.

If it is necessary to replace the coil spring (30384) fit it into the spring mounting on gear wheel (22699) as shown in fig.12. Use a new spring, contained in its plastic ring. Lubricate with grease.

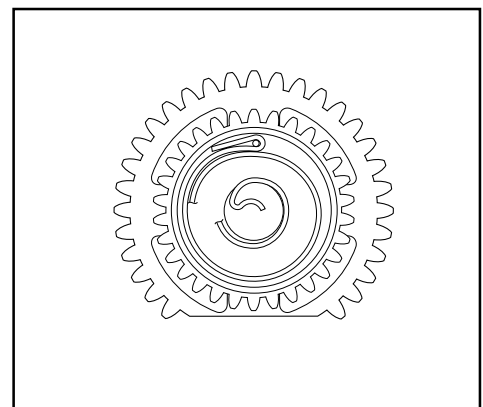

Fig. 12

## Camera body 503CW

## Reassembly

Mount the gear housing (30324) to the mechanism plate.

On the reverse side of the mechanism plate lubricate the hub with grease and fit the shutter stop bar (20912) spring (816802), washer (810404) and clip (817112). Fig. 13.

**Note! The gear housing must be rotated when fitting the stop bar (20912).**

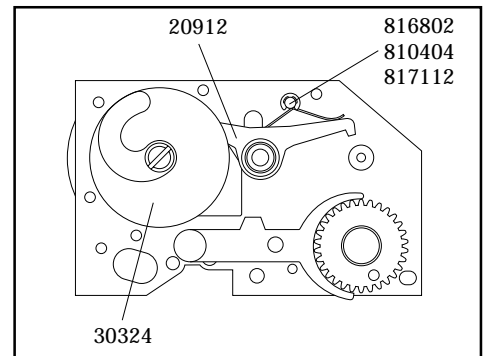

Fig. 13

Lubricate the cam of the gear wheel (13182) with grease and fit to the mechanism plate.

**Note! The position of the gear wheel engagement according to fig.14.**

Hold the gear wheels in position and on the reverse side of the mechanism plate, position washer (810932) and lubricate the hub with grease. Fit gear wheel (22699) together with the coil spring. Lubricate the coil spring with grease.

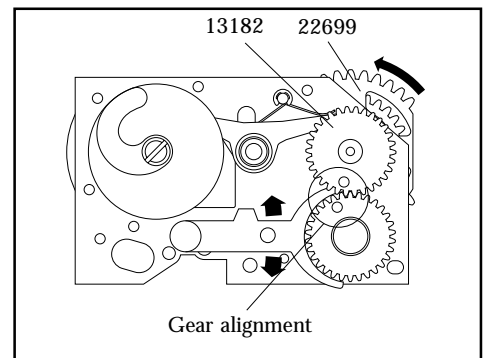

Fig. 14

Assemble the lid (14280) and temporarily secure with the screw (822605). Fig. 15.

Tension the spring by rotating the gear wheel (22699) in the direction shown in fig. 14. Test the operation by pushing the shutter release connecting rod up and down several times (tension the spring after each operation). The gear wheels should rotate freely. Fig. 14.

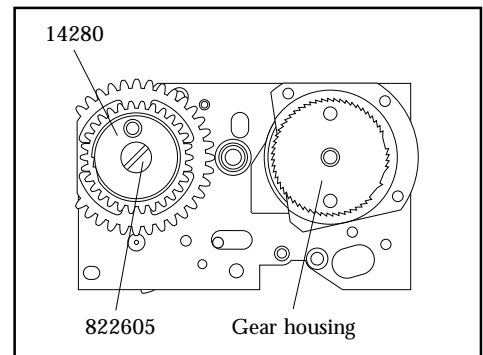

Fig. 15

Lubricate with grease and fit the intermediate gear wheel (13167), bearing bracket (13171), nut (13116) and two screws (820016).

Position the bearing bracket (13171) and mesh the gear teeth, secure the two mounting screws (820016). Fig. 16.

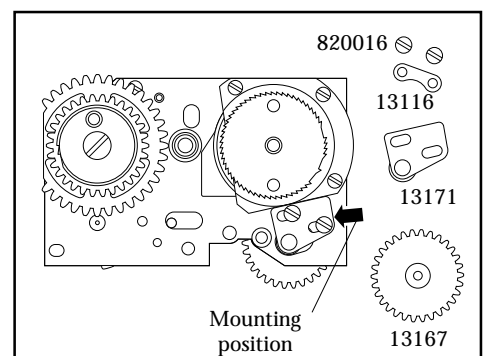

Fig. 16

## Camera body 503CW

## Reassembly

### Fitting the mechanism plate to the right hand wall

On the mechanism plate fit the upper and lower connecting rods to the pins on the gear wheels. (13100) for the upper shutter and (13101) for the lower shutter. Lubricate with grease. Position the auxiliary shutter stop (22436) in place.

Place the mechanism plate in position on the right hand wall. Attach the adjustable pawl assembly (13170) with two screws (820022). Lubricate the pawl with a drop of oil and ensure that it is free to operate. Attach the stop angle (13432) with screw (821017).

Secure the mechanism plate with the remaining three screws (823015), (820020) and (820015).

**Note! The longer connecting rod (13101) which operates the lower shutter is fitted below the lower-left mounting post behind the signal arm.**

Fig. 17.

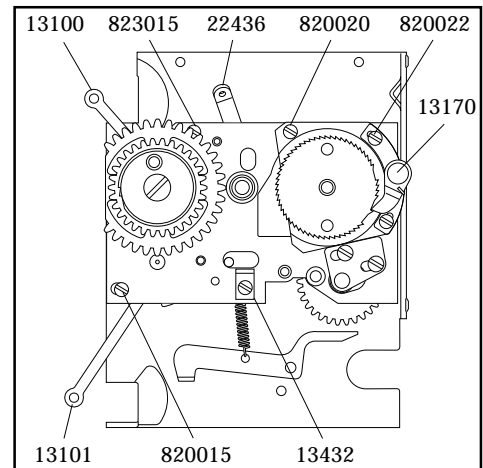

Fig. 17

Connect the push rod (22369) to the release arm (13357). Place the arm on the pre-greased pin (836514).

Fit the S-arm (21167), hub (840701), spring (816914) and secure into position using screw (821032). Check for ease of operation.

Connect the spring 816914 to the S-arm and position the straight end to the pin on the shutter release connecting rod reverse side. Connect spring (814826) between the two pins. Check for ease of operation.

Fig. 18.

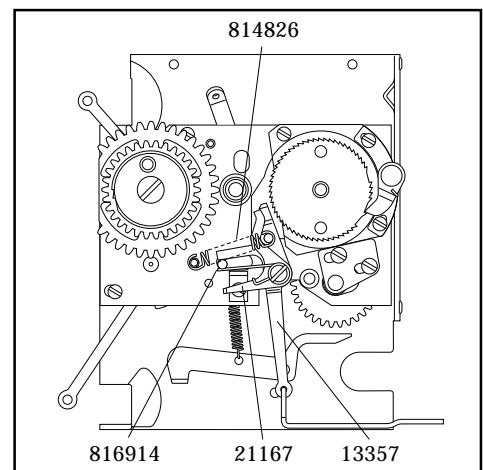

Fig. 18

## Camera body 503CW

## Reassembly

Fit the stop lever (13355) and spring (816752) to the pre-greased hub (13108). Secure with the clip (817119).

Lubricate the hub (13108) with grease and place a shim onto it. This shim can be in several thicknesses for adjustment as follows: 0.10; 0.20; 0.30 mm with corresponding part numbers 810826, 810827, 810828. Attach spring (814827) between the auxiliary shutter stop (22436) and the right hand wall.

Fig. 19.

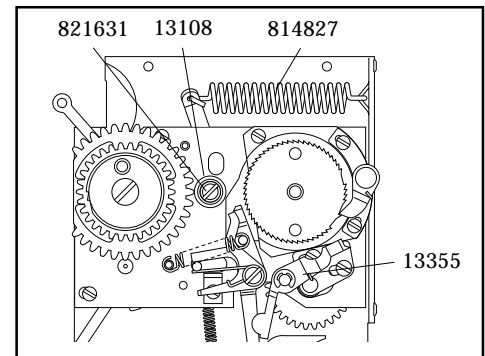

Fig. 19

On the reverse side of the right hand wall fit the mirror actuating lever (13362) and the lens lock (13280). Lubricate with grease. The lens lock pin (13280) fits into a pin on the mirror actuating lever.

Fig. 20.

Secure the mirror actuating lever (13362) temporarily with screw (821631) from the other side according to Fig. 19.

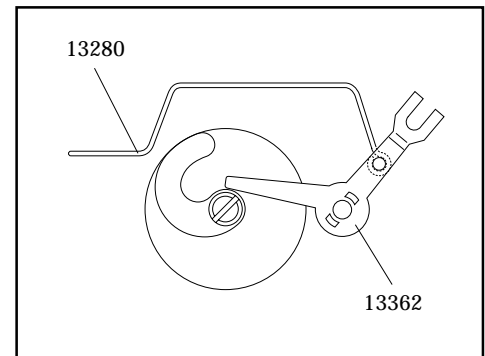

Fig. 20

Fit the mirror catch 13356-1 onto the pin. Lubricate with grease. Connect the spring (816720) with its long shackle in the hole in the right hand wall and the short one under the mirror catch.

Hold the blocking lever and spring and install the push fit cover (30727). Check that the mirror catch moves freely.

Fig. 21.

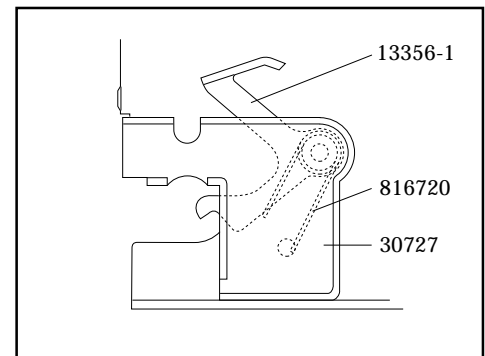

Fig. 21

Connect the right and left hand walls to the bottom plate (30686), secure with six screws (820014).

Apply safety lacquer to screw-threads.

Put back the foam plastic pad (22582).

### Focusing screen frame (22812)

Put the focusing screen frame back and at the same time secure the upper part of the inner side cover (22813).

Fit the spring (30755) and secure with screws (829425).

Fit four screws (820015), two through the right hand wall and two (temporarily) through the left hand wall.

Fig. 22.

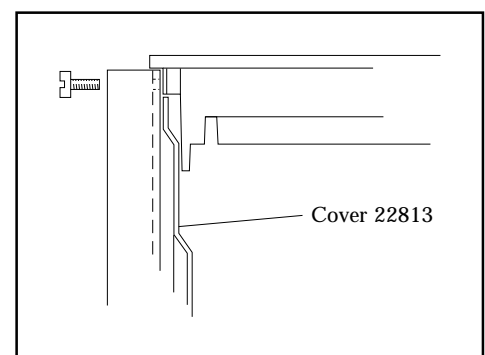

Fig. 22



## Camera body 503CW

## Reassembly

### Rear plate (30300)

Fitting the rear plate

Fig. 23 and 24.

Lubricate the shutter driving arm's shaft hub and the mirror's moving peg with grease. Connect the arm and the connecting rods and fix the rear plate into the chassis. Ensure that the mirror actuating lever grips the pin on the mirror frame and that the mirror is positioned correctly on the upper side of the mirror support.

Connect the driving arm (22781) to the mirror frame and secure with a clip (817115). Do not forget the washer (810649) between the frame and the arm. Check that the mirror and shutter driving arms move freely.

Secure the rear plate to the camera using six screws (820015) and two screws (821017).

Check that the mirror and the auxiliary shutters are centred and move freely. Adjust if necessary the brackets (Qty. 4) in the side hinges of the auxiliary shutter and mirror frame.

If the magazine hook (22423) has been removed, put it back with two screws (823640) and seal the screws with loctite.

Seal between the rear plate and both side walls using black silicone or similar. (Lower and upper end).

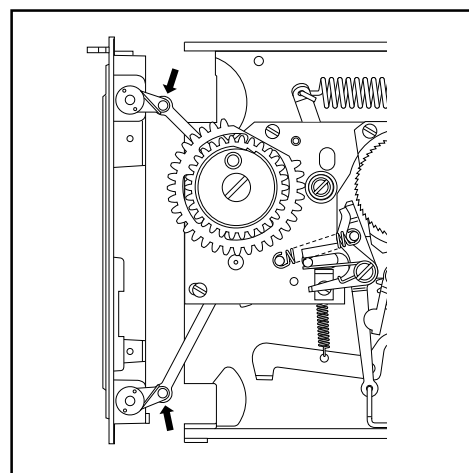

Fig. 23

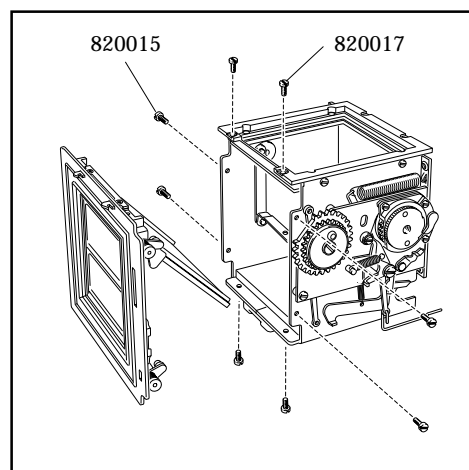

Fig. 24

## Camera body 503CW

## Reassembly

### Front plate (30777)

Fitting the front bayonet plate to the camera body

Tension the drive spring by turning the outer gear wheel clockwise four turns. The front key will be positioned at the red index dot.

A locking pin can be inserted through the inner cog wheel and the bracket to prevent the spring from unwinding.

Install the winding knob V-2206 and tension the gear housing.

**Note! Make sure the aux-shutter is closed at this time.**  
Fig.25.

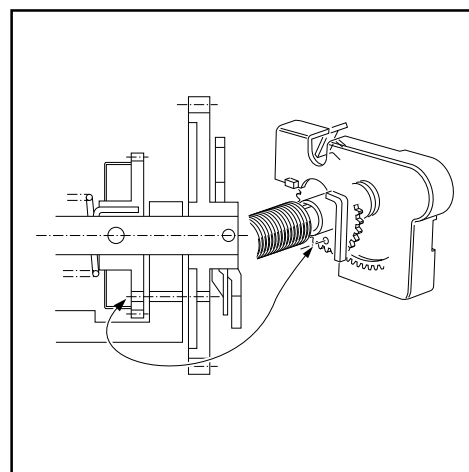

Fig. 25

Install the front bayonet plate. Ensure that the push rod (22369) passes through the hole in the front plate and that the lens lock pin (13280) passes through the appropriate hole when the front plate is fitted and secured.

Secure the two screws (823655) in the bottom plate and seal with loctite. Secure the four screws (820015) in the left and right hand walls, and the two screws (821017) in the focusing screen frame.

Remove the temporary locking pin.  
Fig. 26.

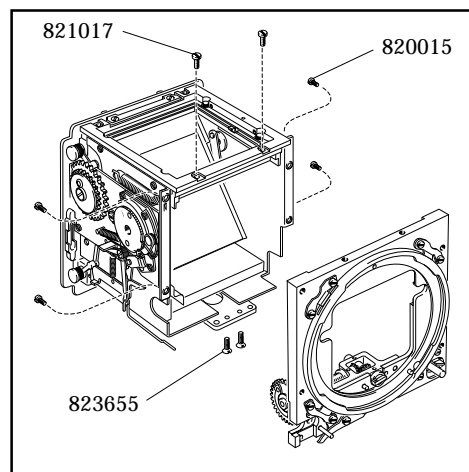

Fig. 26

### Intermediate gear (13112)

Remove the screw (821631) and fit gear wheel (13112). Before meshing, align the gear (22699) with the rear plate and ensure that the adjustable pawl (13170) is in the middle cut out of ratchet wheel (20924).

Hold the mirror actuating lever from the inside and secure the gear wheel (13112) with washer (810532) and screw (821631).

Fig. 27.

Fit the release bar (30375) and the spring (814512).

**Perform the necessary adjustment as described in section 5.**

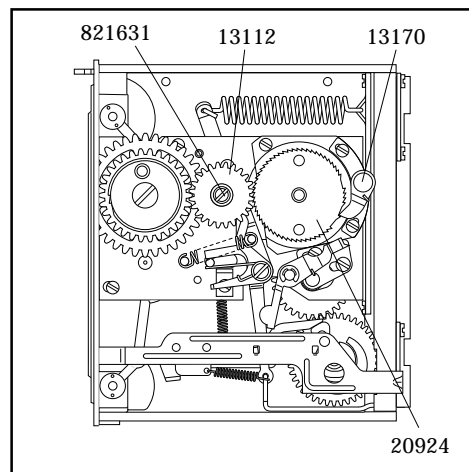

Fig. 27

## Camera body 503CW

## Adjustment

The lubricants mentioned in the text are:

Grease = Isoflex Topas L32

Oil = Isoflex PDP 48

Install the winding knob V-2206 and tension the auxiliary shutter spring (30384) by releasing the pawl (20919). Turn the knob clockwise and tension the spring two turns at this time. Test the camera's function.

If the spring is too tight the pressure can be reduced by operation of the shutter mechanism and then pressing the signal arm down.

Fig. 28.

**Note! Always check that the auxiliary shutter is closed before turning the winding knob, otherwise there is a risk that the top flap of the shutter will be damaged when the mirror moves downwards.**

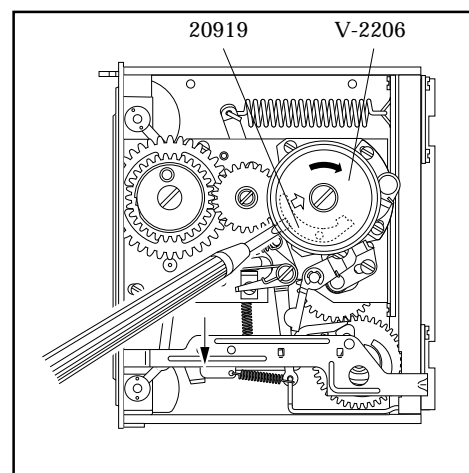

Fig. 28

Temporarily adjust the key position by loosening the screws and moving the bearing bracket (13171) forward until the key position is aligned to the red index dot on the front plate. If the adjustment is insufficient disengage the cogs between the front gear wheel and the gear wheel (13167). Hold the gear by hand during this operation so that the drive spring tension is not lost.

Fig. 29.

Loosen the front plate just sufficiently to ensure that the mesh of the teeth is removed and turn the gear one tooth at a time.

Retighten the screws.

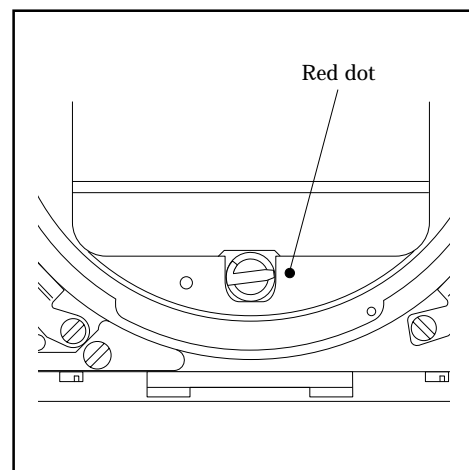

Fig. 29

The camera body should now function normally, i.e. shutter release and winding on can be carried out in the normal manner.

## Camera body 503CW

## Adjustment

### Focal length

The camera body's focal length is inspected and adjusted by using tool V-2229. The focal length is 71.40 mm ± 0.03 mm.

Zero the dial indicator by placing it on surface "A". Mount the front plate "B" into the front bayonet of the camera.

Connect the camera to the focal length gauge. Ensure that the rear plate is flat. In the event of any unevenness loosen the screws which hold the rear plate and push it in the desired direction. Place the ruler with indicator clock onto the gauge and move the indicator around the periphery of the front plate and check that the length is within the tolerance.

Fig. 30.

Adjustment is carried out by moving the camera rear plate forward or backward.

Minor adjustments can be done by striking the front plate tool with a plastic faced hammer.

Fig. 31.

Tighten up all screws.

**Note! The focal length is checked once more when the camera body is mounted in to the camera shell.**

### Adjustment of the front key's angular position

Remove the knob V-2206 and insert the bayonet plate tool 904644. Mount V-2206 again.

Mount the key inspection tool 902658 (V-2075) to the camera's front bayonet plate. Ensure the indicator is pointing upwards when the camera is cocked.

Fig. 32.

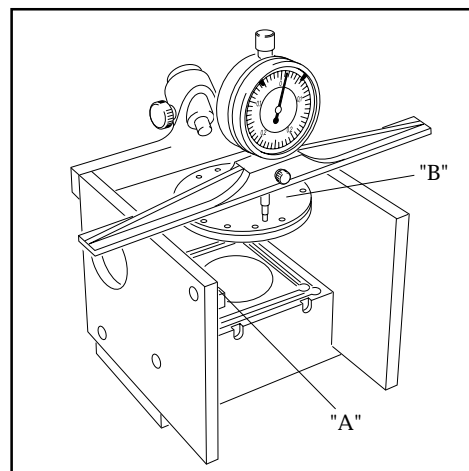

Fig. 30

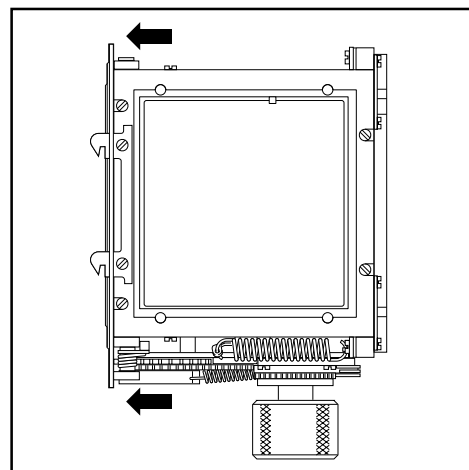

Fig. 31

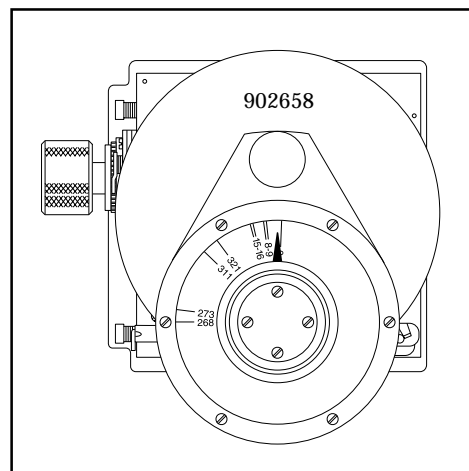

Fig. 32

## Camera body 503CW

## Adjustment

### Adjustment No. 1 (Overtravel)

With the film winding mechanism tensioned, check the angle 15-16° with the bayonet plate tool 904644 pushed hard against the stop arm (13355). Measure the angle with a spring tension of 300 gm/cm. Adjust by altering the position of the bearing bracket (13171). When the correct angle is achieved tighten the screws. Check that meshing between intermediate gear (13167) and the front drive gear is as close as possible without binding. Fig. 33.

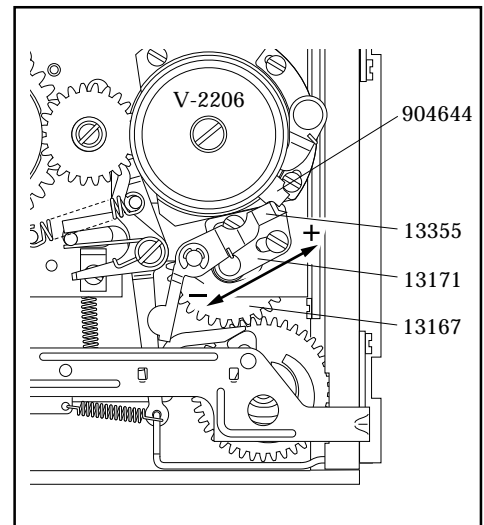

Fig. 33

### Adjustment No. 2 (Cocked position)

With the winding mechanism in the "free" position, (no tension on the winding crank) adjust for an angle of 8-9° by loosening the screws holding the adjustable pawl (13170), and move it until the correct angle is obtained. This measurement should also be carried out at 300 gm/cm. When the adjustment is complete tighten the screws.

Recheck adjustment No. 1 and secure the spring (816507) with safety lacquer.

Fig. 34

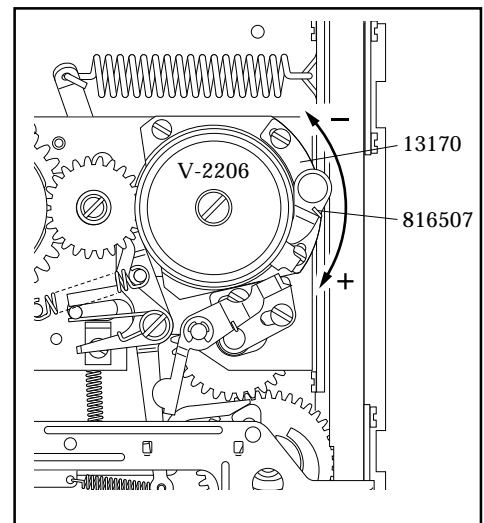

Fig. 34

Possible wear in the front gear (30383) can be checked by increasing the spring pressure of the inspection tool to 1400 gm/cm. The angle value should not fall below 3°. If it does the front gear (30383) should be replaced.

### Inspection of the release sequence (angular value):

Free the mechanism by holding the release button depressed (B-position). The indicator should read between 268-273° at 300 gm/cm.

Let the mechanism turn to fully released position. The angle should be 311°, tolerance: 306.5-321°.

Inspect the pre-released position, this should be 118° with a tolerance 113-122°. If any of the measurements are incorrect the possible cause will be in the bevel gear or the stop gear (13509).

Remove tool 902658( V-2075).

### Adjustment of the release mechanism

Check that the release bar (30375) is free from the signal arm pawl. Adjust by carefully bending the forward part of the signal arm. Use tool V-2200. Minimum free play: 0.2 mm.

With the camera fully cocked the release bar should protrude a maximum of 0.9 mm through the rear plate. Adjust this by bending the release arm (13357) using tool V-2224. Fig. 35.

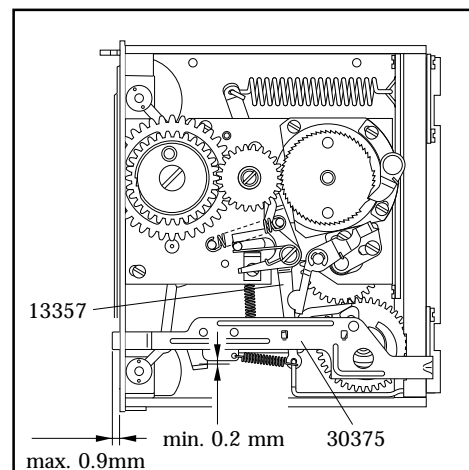

Fig. 35

The mirror function should be checked and possibly adjusted before proceeding to adjust the release mechanism.

The mirror should be locked by the mirror catch lever (13356-1). Movement can be increased or reduced by adjusting the mirror actuating lever (13362). Adjustment is carried out by holding the arm fixed using tool V-2205 and gently bend the forward part of the arm using tool V-2201. Bend downwards for increased mirror movement.

**Note! The inner side cover (22813) must be removed before an adjustment can be made.**

The mirror's overtravel should be min. 1 mm. Lubricate the mirror cam (22355) with grease. Fig. 36.

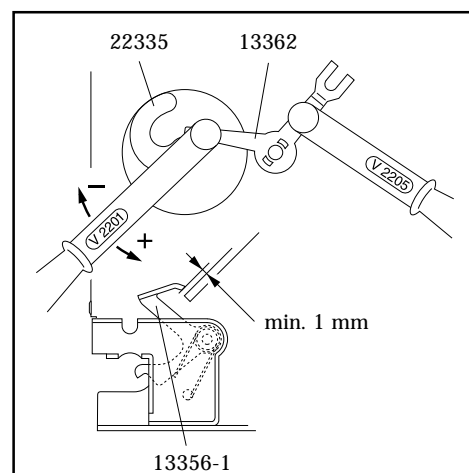

Fig. 36

## Camera body 503CW

## Adjustment

The push rod (22369) is adjusted so that it is set 0.15 mm below the release bar (30375) forward angle setting. Check by using the tool V-5942.

Adjust by gently bending (22369).

Fig. 37.

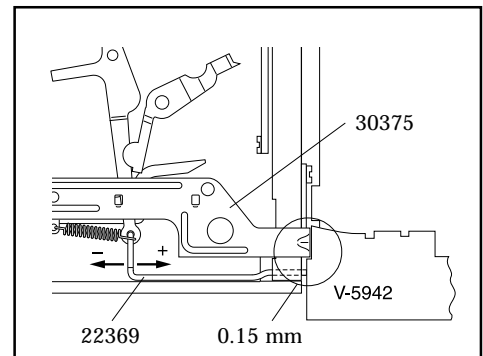

Fig. 37

Position tool V-5942 as shown and press against the front plate. The mechanism should not release. When the tool is moved upwards the mechanism should release.

If a large adjustment is needed bend the release arm (13357) using tool V-2224. Bend forward for an earlier release and backwards for a delay in release. For a small adjustment the push rod (22369) can be bent.

Fig. 38.

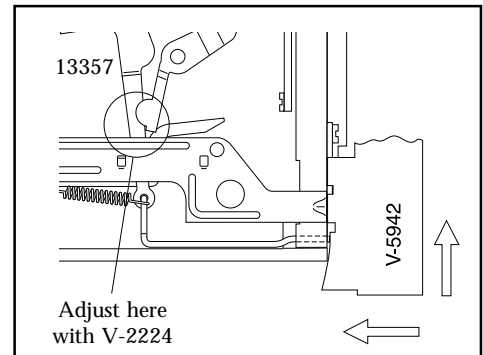

Fig. 38

Fig. 39 and 40.

Pre-release the camera shutter by operating the S-arm (21167) towards the angle stop (13432). Shutter release should occur just as the S-arm strikes the angled stop and at the same time cam "A" should be positioned on stop "B".

Adjust by bending the S-arm with tool V-2202. Do not forget to re-adjust the angle stop (13432).

Minor adjustments can be carried out by just moving or bending the angle stop (13432) without any adjustments to the S-arm.

**Note! That spring 816914 should not rest against the angle stop when the camera is completely released.**

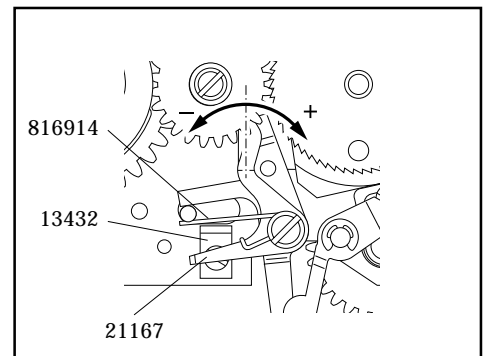

Fig. 39

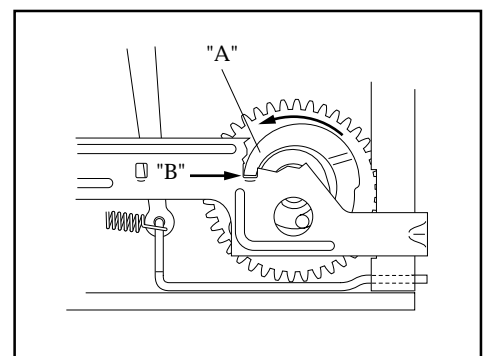

Fig. 40

## Camera body 503CW

## Adjustment

### Adjustment of the release sequence

Make sure the winding knob V-2206 and the bayonet plate tool 904644 are installed.

Release the camera and keep it released by holding the release bar and push rod back.

Move the release bar and push rod to the front slowly and observe the closing sequence.

Fig. 41.

1. Key releases to fully released position.
2. Auxiliary shutter closes. Note that the winding knob is blocked all the time until the auxiliary shutter closes.
3. The stop lever disengage giving clearance for the winding knob.

The auxiliary shutter closing position can be adjusted by bending the rear of the release arm (13357) which bears on pin "A" as shown.

Use the tool V-2203.

Check for free play between the release bar and signal arm when the camera is fully released.

Fig. 42.

**Note! The final sequence check is done when the chassis is mounted in to the shell by using the exposure gauge V-2354. (See page 5:11).**

Check that the auxiliary shutter does not close spontaneously when the camera is pre-released. Carry out a number of operations of the release arm (13357). If the auxiliary shutters do close using this test, adjust the tongue on lever (22769) which stops the release arm against the signal arm.

Check the lever does not jam between the release arm and the signal arm when the camera is released.

Test by operating the shutter and letting the release bar return slowly. Check that the lever has a small amount of play during this movement.

Fig. 43.

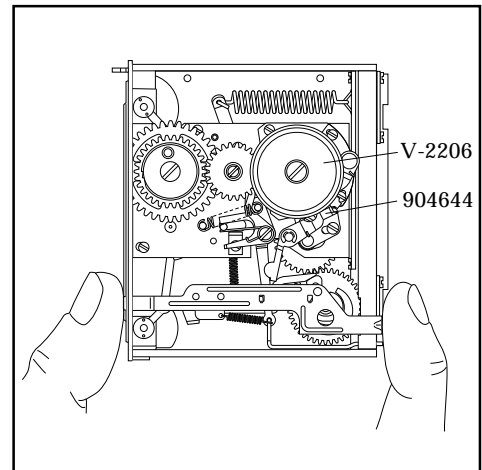

Fig. 41

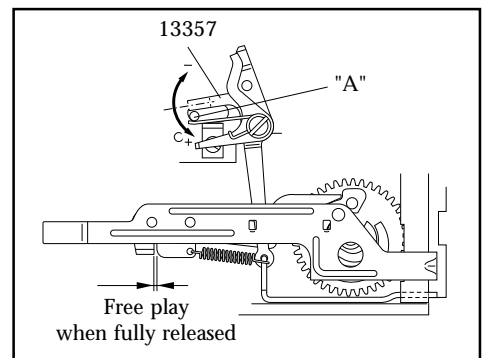

Fig. 42

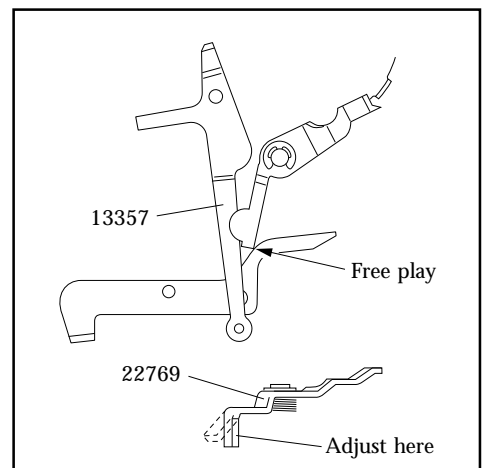

Fig. 43



## Camera body 503CW

## Adjustment

Operate the winding knob V-2206 to cock the shutter. Check that the bayonet plate tool 904644 is blocked by the stop lever (22769) when the camera is completely cocked.

Adjust by bending the front of the lever. The lever engagement should be retained until the camera is fully released.

Fig. 44.

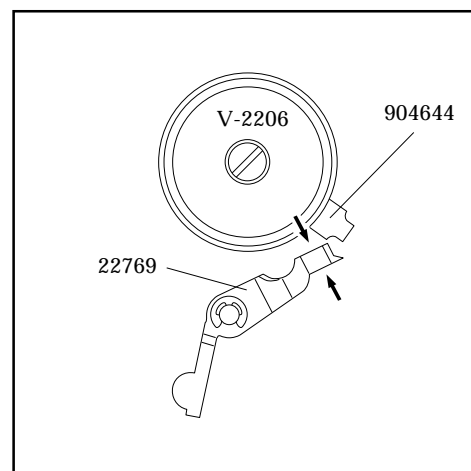

Fig. 44

### Fitting the damping ring (22287)

Hold the lid (14280) in position and unscrew (822605). Position the damping ring (22287). Lubricate carefully with grease and insert washer (810836) with the concave side facing up. Refit the screw and tighten. Check for ease of movement. Operate the camera and check that the auxiliary shutters close distinctly without slamming.

Fig. 45.

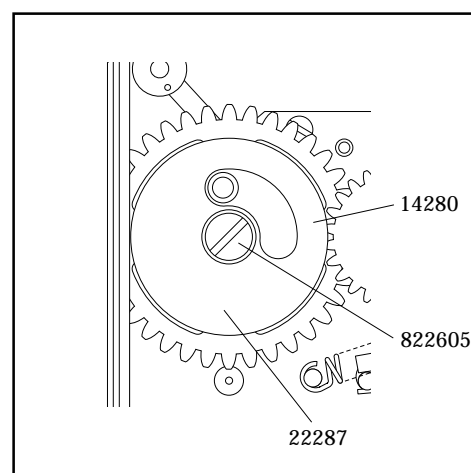

Fig. 45

Adjust the spring pressure if necessary. Test the function by opening the shutter and letting it close slowly. Both shutters should close steadily. Check that the shutters are level to ensure a light seal around the edge.

Operate the pre-release lever so that the camera auxiliary shutters opens to the B-position. Check that the auxiliary shutter blinds do not influence on the light path. Alignment of the blinds can be adjusted by holding the shaft using pliers and carefully bending in the desired direction.

Check that the shutter pivot point is not loose on the shaft. If this is the case a new shutter must be fitted. Check that the top shutter is positioned 4-5 mm in front of the lower shutter blind on closing.

Fig. 46.

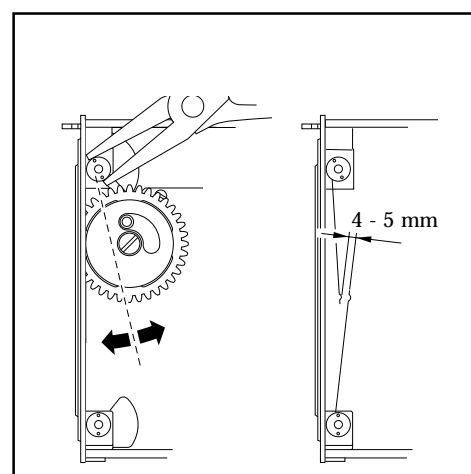

Fig. 46

**Secure all screws with safety lacquer.**

## Camera body 503CW

## Adjustment

### Fitting the Circuit board (22575) \*22882

**CAUTION! When handling the circuit board a grounded bench mat and a wrist strap must be used to prevent ESD damage.**

Put the insulating plate (22746) in position and place the circuit board on top of it. Secure the board by first fitting the two screws (820015) followed by the attachment (22453).

**\* Note! The circuit board (22882) is fixed to the wall by an insulating double-sided tape, screws and attachment.**

Put the photo diode in position on the inside of the bottom part of the left hand wall and secure from the outside with two screws (820325).

Fit the cable holder (12453) and securing the cables with screw (820011).

Fig. 47.

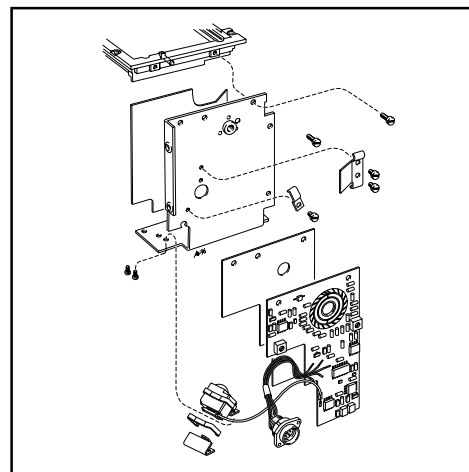

Fig. 47

### Fitting the camera body into the shell

Install the lens release button (13139), release button (22759), buffer (22367), and the distance washers (810620) into the shell.

Put the teflon cone (103373) in position on the camera body.

The camera body can be fitted into the shell.

Fig. 48.

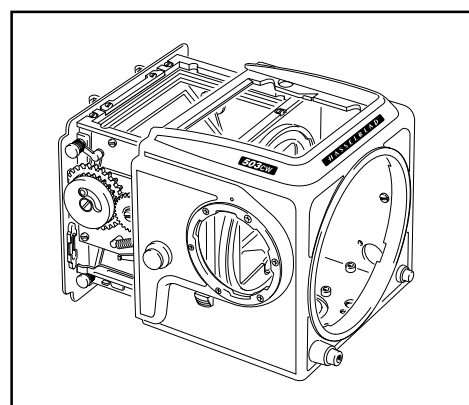

Fig. 48

**Note! That the S-arm (21167) has to be fitted using a spring hook to ensure that the pre-lease button (22385) is positioned beneath the S-lever.**

Fig. 49.

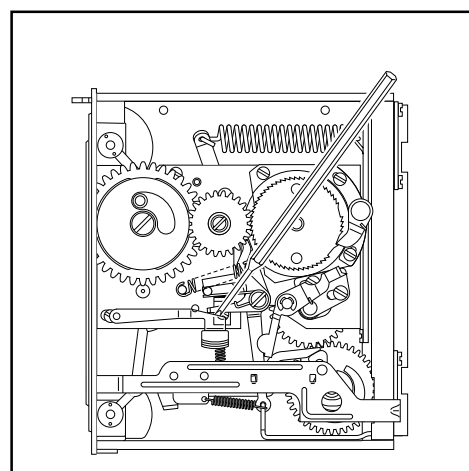

Fig. 49

\* From camera serial No. 19ER18271

## Camera body 503CW

## Adjustment

Adjust the lower rear plate/shell alignment and tighten the two rear screws (829755) and seal with loctite. Fit and tighten the two front screws (820781).

Check the upper edge alignment of rear plate and shell. Adjust, if necessary, the two screws (825760) which are accessible behind the leathers mounted on the shell.

**Note! The rear edge of the shell must not protrude over the rear plate at any point.**

Fit the tripod foot (30763) with the remaining six screws (829755). Screws sealed with loctite.

Fit the washer (22799) and coupling (22767). Secure with screw (830060).

Fit the ISO selector knob and secure it with the screw (822701). Fit the shim (22473) and leather (13374). Do not damage the sliding contacts.

Fit the two screws (823335) behind the leather securing the chassis connector.

Operate the pre-release on the camera body and fit the front gear cover (22876) and a new side cover (22813), if it has been removed.

The side cover is held in position by double sided tape and the upper part of it held by the screen frame.

Mount the spring (30775) in the mirror box using the small screwdriver (Tool No. 905020).

Mount the winding crank.

Operate the camera body and make sure it is working properly.

### Final checks

Place the camera in the focusing gauge V-2229. Zero the dial indicator by placing it on surface "A". Mount the front plate "B" into the front bayonet of the camera. Place the ruler with indicator clock onto the gauge and move the indicator around the periphery of the front plate and check that the length is within the tolerance  $\pm 0.03$  mm. If too long, the camera can be shortened by carefully striking the plate with a plastic hammer. (Focal length is 71.40 mm).

**Note! If the camera is too short it must be taken out from the shell again for an adjustment.**

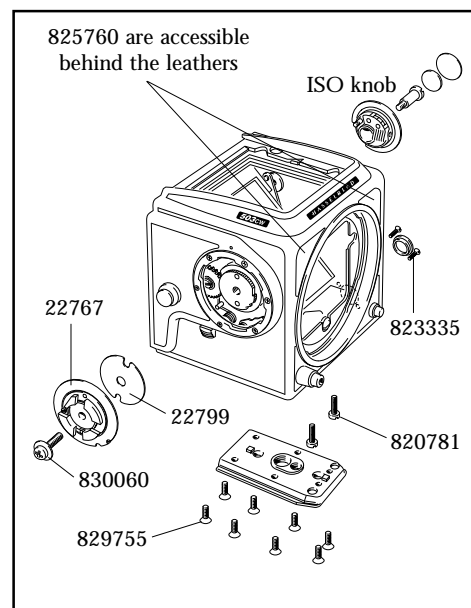

Fig. 50

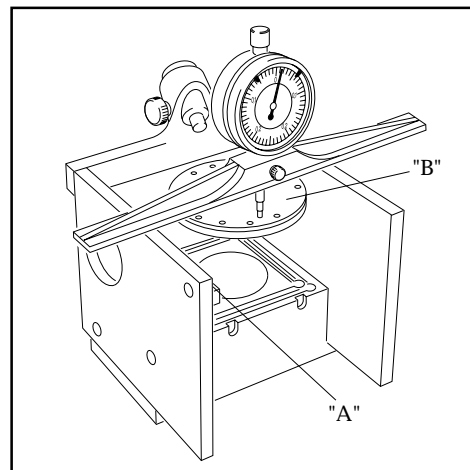

Fig. 51

## Camera body 503CW

## Adjustment

Check the mirror 45° angle using the sighting tube which fits in the holder on the gauge. Tighten the locking screw. Shine a light source towards the oval cut-out in the upper part of the tube so that the white ring of the ocular is illuminated.

When the mirror is at 45° the pattern in the sighting tube will appear as shown.

Check that the inner white circle is symmetrical and does not lie outside the inner black field.

The mirror level is adjusted by bending the mirror support (13121) on the left hand wall and/or the mirror catch lever (13356-1).

Fig. 52.

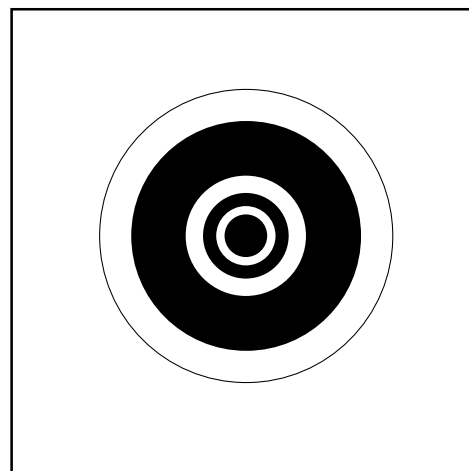

Fig. 52

After adjustment is completed remove the sighting tube.

To adjust the screen position there are four special screws (21606) in the screen frame. Use key V-4704 for the adjustment. Each rotation of the screw alters the height by 0.35 mm. A cross is engraved on the tool's upper surface to help determine the amount of adjustment that has been carried out.

First check the flatness of the screen. Use the screen adapter V-4705 and the ruler with the indicator clock. The same measurement should be obtained at all four corners.

Fig. 53.

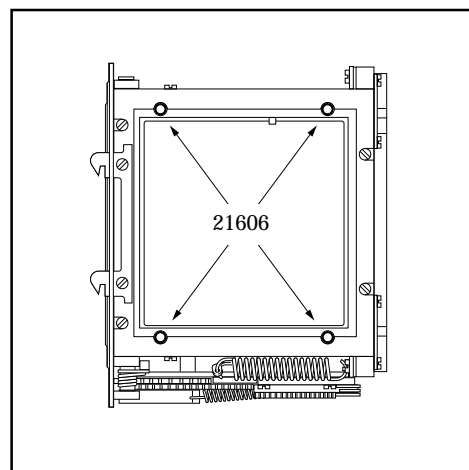

Fig. 53

Then fit tool V-4151 into the camera's front bayonet plate. The tool should be powered by 6 volt DC.

Position the microscope V-2236 on the screen adapter V-4705. Adjust (all four screws) the screen height with V-4704 until the green line is central between the two red lines.

Use the engraved cross on tool as reference.

Fig. 54.

Remove the camera body from V-2229 and secure the screws (21606) with safety lacquer.

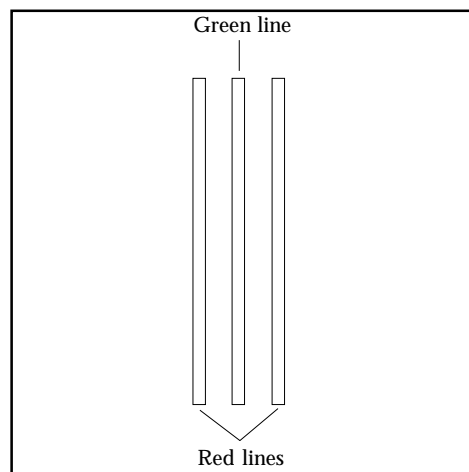

Fig. 54

## Camera body 503CW

## Adjustment

Check the camera functions. Check that the auxiliary shutter is clear of the internal covers.

Check the release sequence using a micrometer V-2354.

Mount the micrometer in the exposure button's cable release socket. Carefully screw in the micrometer's screw until the camera releases. After releasing it should be possible to turn the micrometer a further 3 to 5 notches before it bottoms. Screw out the micrometer slowly and observe the closing sequence.

1. Key releases to fully released position.
2. Auxiliary shutter closes. Note that the winding knob is blocked all the time until the auxiliary shutter closes.
3. The stop lever disengage giving clearance for the winding knob.

**Note! If the release sequence is incorrect the camera should be dismantled from the camera shell and adjusted as previously described in section "adjustment of the release mechanism", page 5:6.**

Check that a magazine can be fitted on the camera and that the locking functions work properly.

If the lock does not function the magazine hook can be adjusted by filing.

Ensure when filing that tests are made often and finally that the magazine fits snugly otherwise it will result in play between the camera body and the magazine.

Mount the screen and the focusing hood.

Test run the camera with loaded magazine and a lens fitted.

Check the flash metering system.

## Calibration and control of the flash metering system TTL

Control/calibration should be carried out each time the camera has been in for repair.  
The tolerance for the flash meter is  $\pm 0.3$  EV at all settings.

If the Hasselblad Service System 970600 is used, follow the step by step instruction in the STS user manual.

Note! For calibration work use ISO 100 and LV15. \* (ISO 400/LV12).

If the Test box 902474 is used follow the instruction below.

### Calibration requires the following test equipment:

- Planar CF80 mm lens with controlled diaphragm values.  
Deviation max.  $\pm 10\%$ .
- Magazine fitted with Kodak's grey card.
- Stabilized DC power supply adjustable to 7.5 volt  $\pm 0.1$  volt.
- Calibrated light box with LV12 and 15.
- Test box 902474.
- Non-conductive trimmer, 2 - 2,5mm.

### Set-up for calibration:

Lens	Shutter Aperture	B or F f 5.6	
Camera body	ISO	100	* (400)
Magazine	Fitted with grey card		
Test box 902474	Exposure knob Tolerance knob	0 Trim	* (+1)
Power supply	Voltage	7.5 $\pm$ 0.1v	
Light box	LV K-factor	15 1.3	* (12)

\* From camera serial No. from 19ER18271 - See Service info No. 12/98

## Camera body 503CW

## Adjustment

### Calibration

On pressing the MEASURE button one of the three LED's will light. The variable resistor in the camera (access behind the leather beside the ISO dial) should be turned so that the green LED lights when the MEASURE button is pressed again.

If the red LED lights, the resistor is turned anticlockwise and if the yellow LED lights, it is turned clockwise. At least two seconds must be allowed between measurements.

### Control

To ensure the ISO dial functions, the measurement should also be made for two other ISO settings (50 and 800). \* **(100 and 1600)**.

In each case the green LED should light when the MEASURE button is pressed.

ISO	Exposure knob	Tolerance knob	LV
50	+ 1	1/2	15
800	0	1/2	12
<b>100</b>	<b>0</b>	<b>1/2</b>	<b>15</b>
<b>1600</b>	<b>- 1</b>	<b>1/2</b>	<b>12</b>

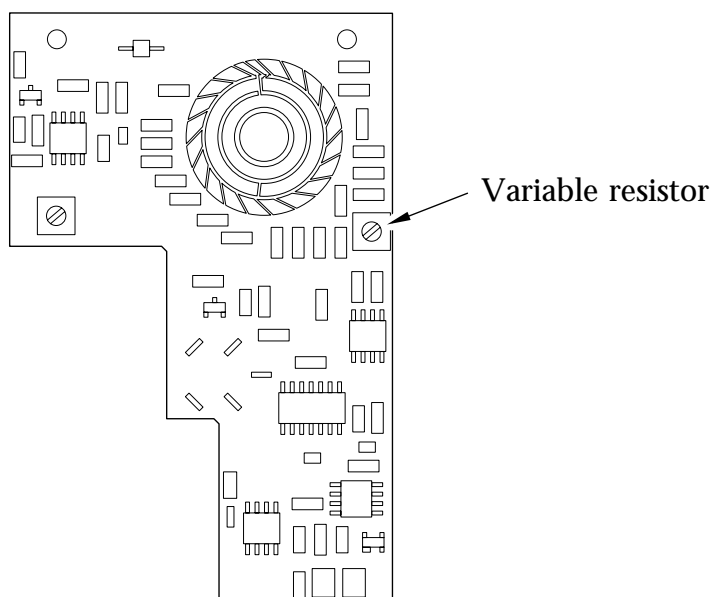

\* From camera serial No. from 19ER18271 - See Service info No. 12/98

## Camera body 503CW

## Front bayonet plate

### Front plate reassembly

Fit the four bayonet tongues (103439) and secure with eight screws (820425).

Fit the release button return spring (21096) with one screw (820015).

Behind the front plate glue the two sponge seals (13212) and (13213) as well as the foils (22829) and (22832) into place.

Place the lens catch lever (103440) in position and fit the cover plate (105107). Secure with screw (823440). Install the spacer (810409) and the spring (816858). Secure the second screw (823440). Check the lens catch lever for ease of operation.

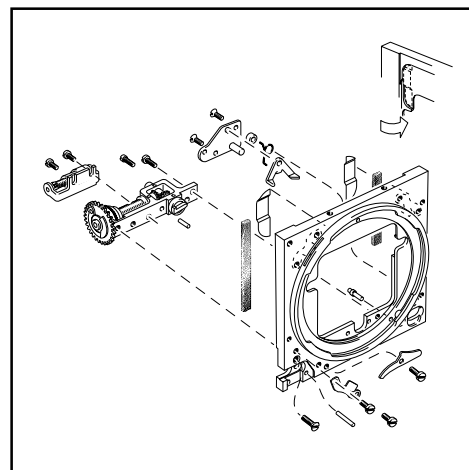

Fig. 55

### Front gear (30383)

Check the front gear ease of operation. The long shaft from the drive gear wheel to the bevel gear wheel sometimes has too little play which can give rise to tightness. A light blow with a plastic faced hammer on the cog wheel end of the shaft will generally overcome the problem.

Fit the front gear on the front bayonet plate using one screw (823019) in the front and one (820018) from the rear. Check the freedom of operation. Do not tighten the screws to much.

Centring the front gear key.

Mount the tool 902658 (V-2075) into the lens bayonet plate and connect tool 902918 (V-2219). Turn the key using 902918 to a vertical position. Check that the free play is even in both directions. If there is more resistance at one direction than the other move the front gear to obtain a balance. Carry out the same procedure with the key in a horizontal position. Also check at the 180° points in both vertical and horizontal position.

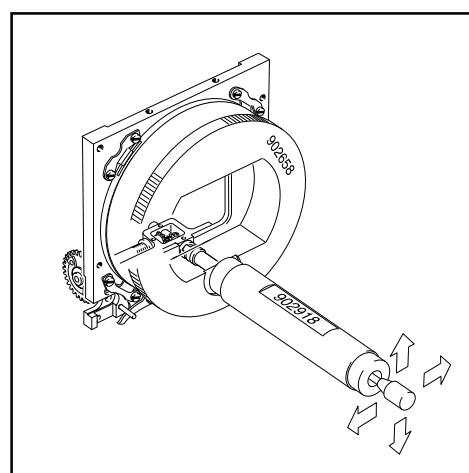

Fig. 56

When the key is centralised tighten both screws in the front gear and secure with safety lacquer.



## Camera body 503CW

## Front bayonet plate

The hole for the locating pin (812202) is bored with 1.15 mm drill. Use tool V-2211 for driving in the pin. Drive the pin in until the face of the tool touches the front bayonet plate. When a new front plate is installed the hole must be drilled using tool 902658 (V-2075), which is equipped with two drill bushes.

Fit the governor (30386) using two screws (820014), ensure the gears mesh and then secure the screws.

Remove the swarf and lubricate the bevel gears with grease. Force grease using a syringe into the three small holes and lubricate the weight of the centrifugal brake.  
**Note! Do not over lubricate.**

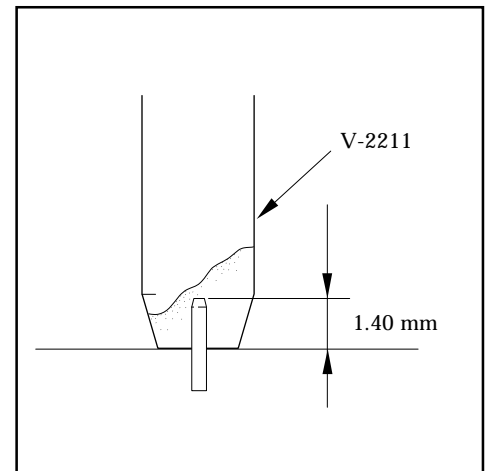

Fig. 57

## Camera body 503CW

## Auxillary shutter & Mirror

### Exchanging the mirror (22775)

Release the camera.

Inside the mirror box, remove the clip "A" and disengage the arm (22781) from the mirror frame. Remove the washer (810649) located behind the arm and the frame.

Remove the sleeve (22800).

Fig. 58.

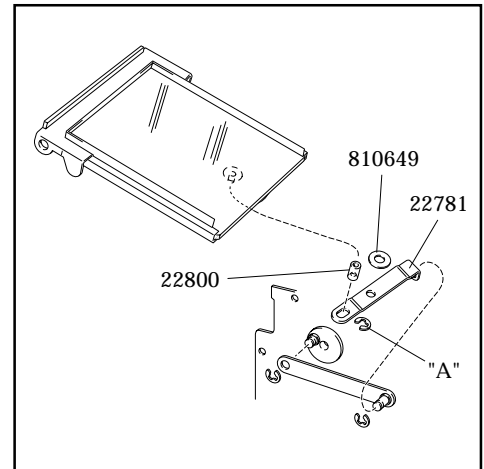

Fig. 58

Carefully wind on until the mirror is visible in the front plate cut-away.

Remove the mirror (22775) and the light trap (22776) which is placed underneath the mirror.

Fig. 59.

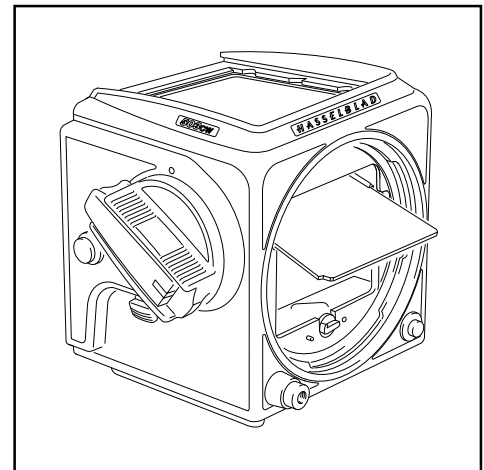

Fig. 59

After a new mirror has been mounted in to the frame check for ease of operation.

Mount a new sleeve (22800) with the counter sunk side facing out.

**Note! If the spring (22804) has to be replaced, the new one should be glued in the mirror frame with Loctite 480.**

### Exchanging the auxiliary shutter

**Note! For convenience use the aux. shutter jig V-5423 when removing/mounting the pins (811108).**

Remove the two pins (811108), spring retainer, spring (816805) and lever 13185.

Remove the safety lacquer and loosen the locking screws (825661). Remove the hubs (840514).

The upper shutter flap and mirror frame can now be removed. Ensure that all adjustment washers on the shaft are retained. The lower shutter flap is dismantled in a similar manner. The light trap 13125 is held in place by two screws (821203).

Fig. 60.

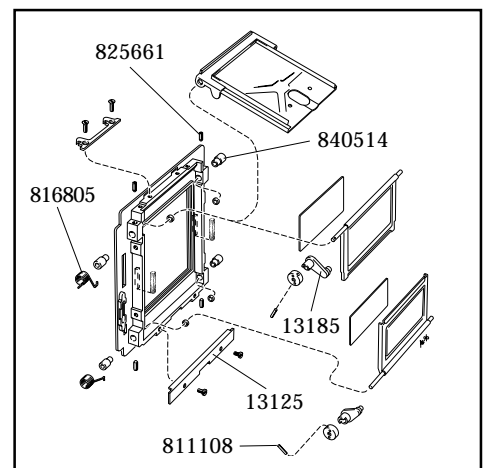

Fig. 60

## Camera body 503CW

## Auxillary shutter & Mirror

Remount the mirror frame and the upper shutter flap by holding the frame in position and aligning the upper shutter flap to the bearing holes.

Push in both bearing hubs and centralise the mirror and shutter flap side movement by using shim washers.

These come in two thicknesses 0.10 and 0.20 mm (810503) and (810505) respectively.

Tighten up both screws (825661) and secure with safety lacquer.

Fit a washer (810503) on each side of the lower shutter flap shaft and mount in the same way as the upper one.

Check that the shutter flaps and the mirror frame move freely and that the flaps are central to the rear plate inner frame.

Fig. 61.

Check that the foam plastic dampers (13397) are in place and glued to the rear plate where the flaps meet.

Assemble the lever, spring and spring retainer. Locate the spring so the three items are together.

Connect the three items to the shutter shaft and secure it with pin (811108).

Fig. 62.

The lower shutter is completed in the same manner but note that a weaker spring is used, (816804).

Check that the upper shutter spring pressure is approximately twice as strong as the lower shutter.

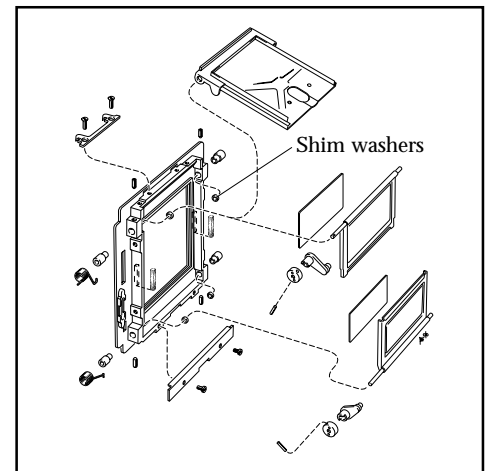

Fig. 61

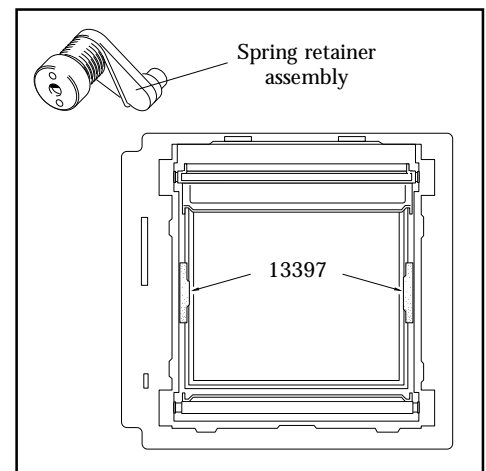
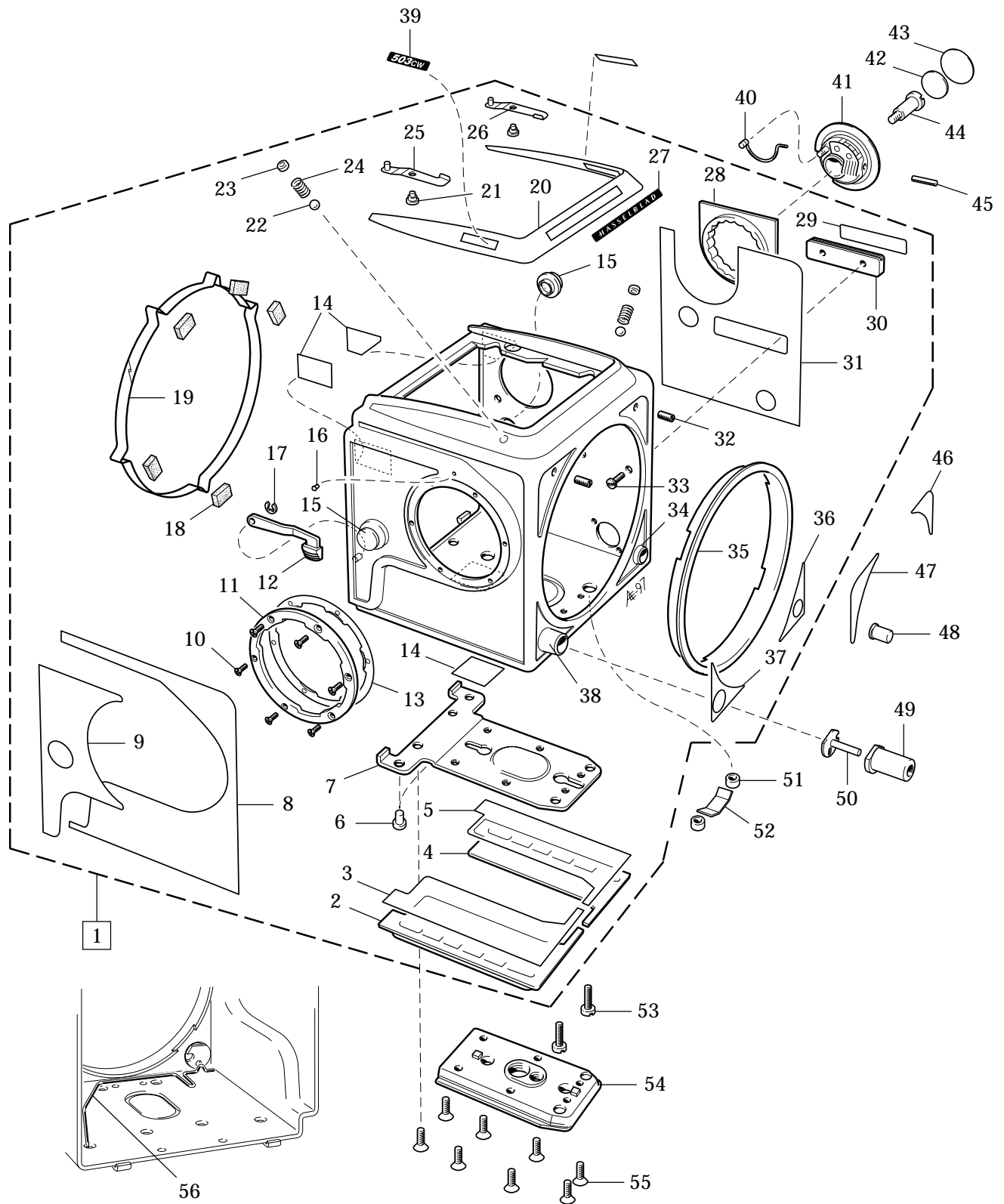

Fig. 62

# Camera body 503CW



# H A S S E L B L A D

## Camera body 503CW

7

Pos No.	Pcs	Spare Part No.	Description	Remark	
1	1	40 393	Shell, complete (chrome)	Part No. 40394 (black)	
2	1	30 762	Support, right		
3	1	105 872	Tape		
4	1	30 760	Support, left		
5	1	105 870	Tape		
6	2	831 502	Rivet		
7	1	40 387	Support		
8	1	103 504	Leather		
9	1	105 509	Leather		
10	6	829 304	Screw		
11	1	103 387	Bayonet	From camera serial No. 19ER18271	
12	1	22 385	Quick release arm		
13	1	103 388	Bayonet spring		
14	3	22 514	Reflection protector		
15	2	13 466	Strap button		
16	1	103 536	Index		
17	1	817 112	Clip		
18	5	13 315	Foam plastic pad		
19	1	22 515	Locking ring		
20	1	105 926	Leather		
21	2	835 001	Rivet		
22	2	809 120	Steel ball		
23	2	12 978	Plate		
24	2	815 604	Spring		
25	1	13 906	Holder, right		
26	1	13 907	Holder, left		
27	1	13 190 -1	Name plate		
28	1	40 331	ISO plate		
	1	40 417	ISO plate		
29	1	22 607	Leather		
30	1	22 472	Accessory rail		
31	1	22 455	Leather		
32	2	825 760	Screw		
33	2	821 661	Screw		
34	1	105 498	Bushing		
35	1	22 516	Front ring		
36	1	103 510	Leather		
37	1	103 509	Leather		
38	1	105 357	Bushing		
39	2	22 502	Name plate		
40	1	22 587	Spring		
41	1	22 495	ISO Selector		
42	1	22 473	Shim		
43	1	13 374	Leather		
44	1	822 701	Screw		
45	1	22 533	Dog		
46	1	103 508	Leather		
47	1	103 507	Leather		
48	1	13 139	Lens release button		
49	1	22 759	Release button		
50	1	22 367	Buffer		
51	2	810 620	Spacer		
52	1	103 424	Spring		
53	2	820 781	Screw		
54	1	30763	Tripod foot		
55	8	829 755	Screw		
56	1	22 850	Spring		From serial No. 19EU11261 (Replaces p/n 21096, page 11)

# Camera body 503CW

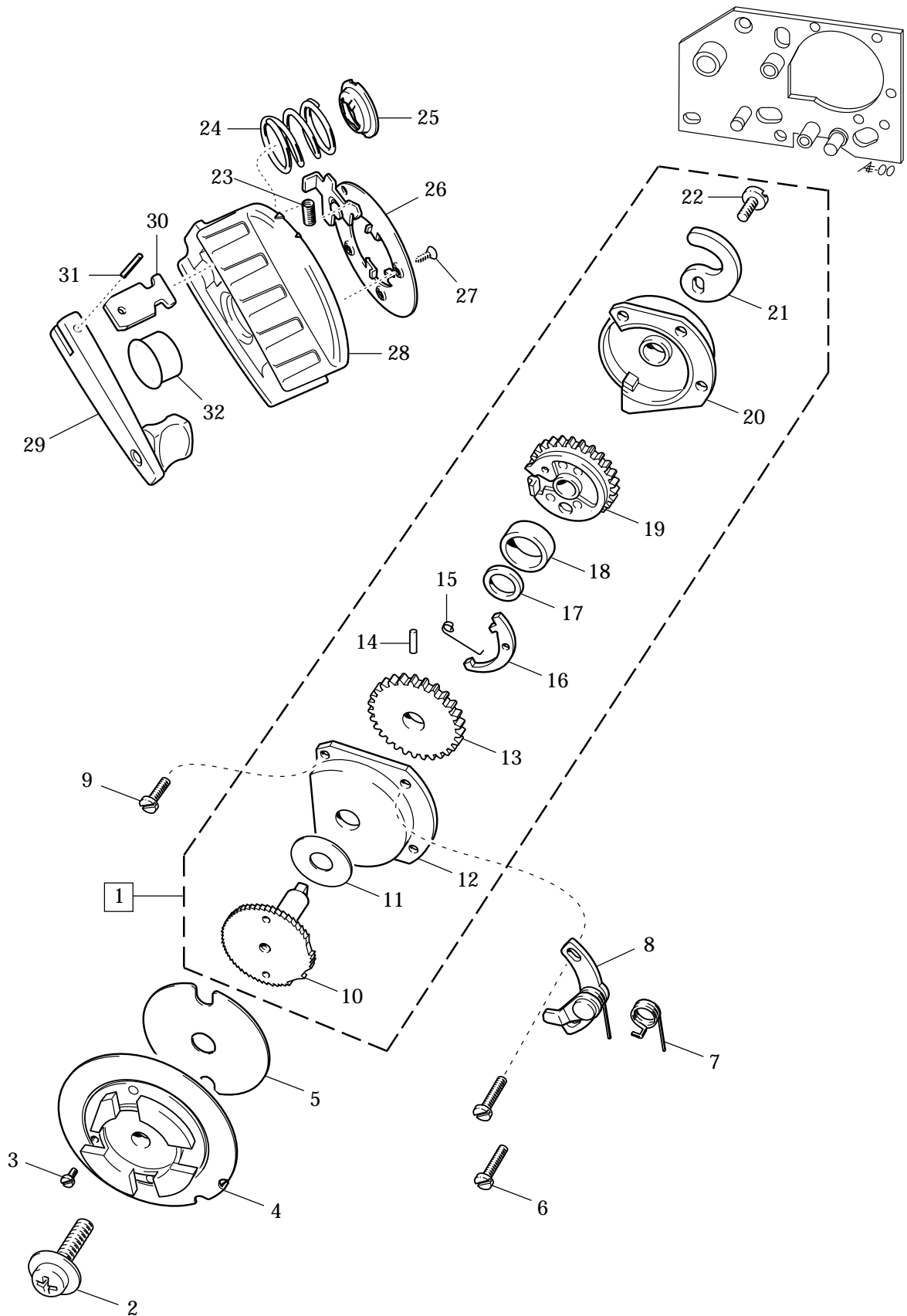

# H A S S E L B L A D

## Camera body 503CW

8

Pos No.	Pcs	Spare Part No.	Description	Remark	
1	1	30 324	Gear housing	Complete	
2	1	830 060	Screw		
3	1	820 415	Screw		
4	1	22 767	Coupling		
5	1	22 799	Washer		Alternatively 2 pcs
6	2	820 020	Screw		
7	1	816 507	Spring		
8	1	13 170	Adjustable pawl		
9	1	820 019	Screw		
10	1	20 924	Ratchet wheel		
11	1	810 840	Washer		
12	1	30 304	Gear housing, front		
13	1	13 169	Gear		
14	1	812 106	Pin		
15	1	816 504	Spring		
16	1	20 919	Hook		
17	1	810 826	Washer		
18	1	810 938	Locking ring		
19	1	13 509	Stop gear		
20	1	13 157	Gear housing, rear		
21	1	22 355	Mirror cam		
22	1	821 033	Screw		
23	1	815 707	Spring		New type of winding crank from camera serial No. 19EU11514
24	1	815 904	Spring		
25	1	103 516	Washer		
26	1	412 105	Crank bayonet		
27	3	826 401	Screw		
28	1	412 323	Crank support		
29	1	412 104	Crank arm		
30	1	103 514	Slide		
31	1	812 301	Pin		
32	1	22 683	Rubber plug		

# Camera body 503CW

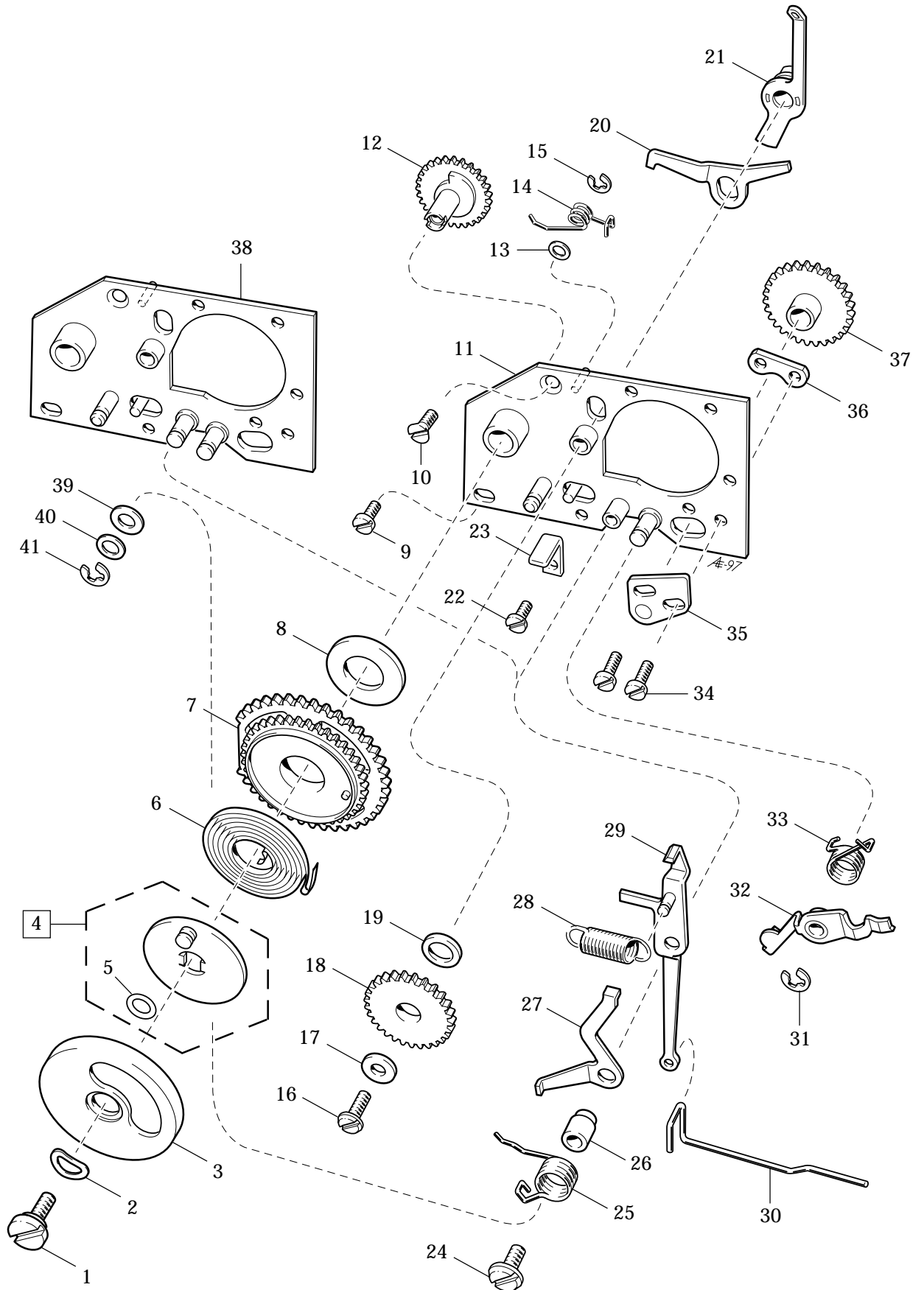



# H A S S E L B L A D

## Camera body 503CW

9

Pos No.	Pcs	Spare Part No.	Description	Remark
1	1	822 605	Screw	
2	1	810 836	Washer	
3	1	22 287	Damping ring	
4	1	14 280	Lid	
5	1	14 278	O-ring	
6	1	30 384	Spring	
7	1	22 699	Gear	
8	1	810 953	Washer (0.3 mm)	
9	1	820 015	Screw	
10	1	823 015	Screw	
11	1	21 125-1	Mechanism plate	
12	1	13 182	Gear	
13	1	810 404	Washer (0.3 mm)	
14	1	816 802	Spring	
15	1	817 112	Clip	
16	1	821 631	Screw	
17	1	810 532	Washer	
18	1	13 112	Gear	
19	1	810 826	Washer (0.10 mm)	For adjustment 810 827 (0.20 mm)
20	1	20 912	Stop bar	
21	1	22 436	Aux. shutter stop	
22	1	821 017	Screw	
23	1	13 432	Stop angle	
24	1	821 032	Screw	
25	1	816 914	Spring	
26	1	840 701	Hub	
27	1	21 167	S-arm	
28	1	814 826	Spring	
29	1	13 357	Release arm	
30	1	22 369	Push rod	
31	1	817 119	Clip	
32	1	22 769	Stop lever	
33	1	816 752	Spring	
34	2	820 016	Screw	
35	1	13 171	Bearing bracket	
36	1	13 116	Fixing plate	
37	1	13 167	Gear	
38	1	21 125-1	Mechanism plate	From serial No. 19ET10850
39	1	810 729	Washer (0.5 mm)	"
40	1	810 705	Washer (0.2 mm)	"
41	1	817 119	Clip	"

Camera body 503CW

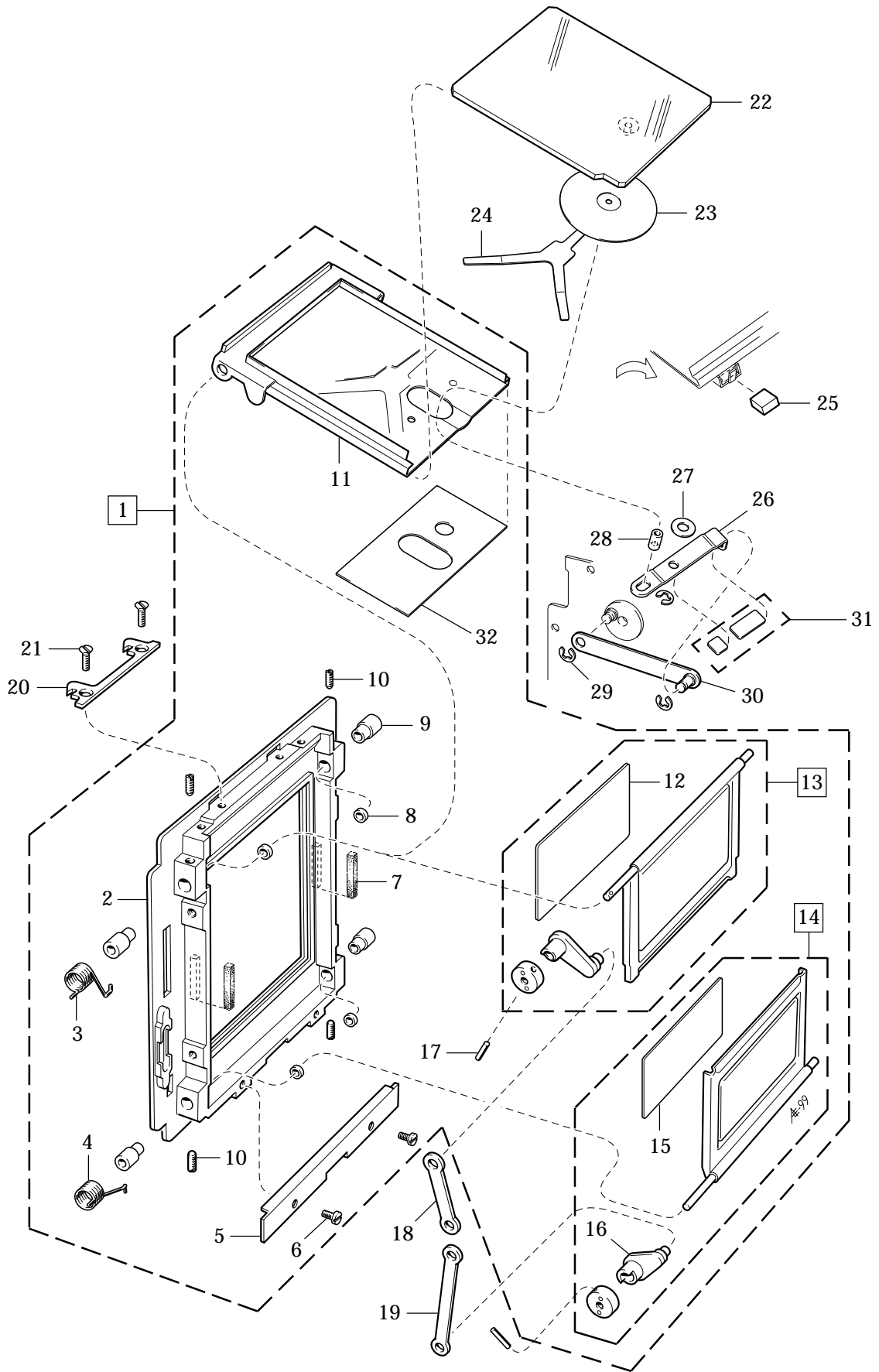

# H A S S E L B L A D

## Camera body 503CW

# 10

Pos No.	Pcs	Spare Part No.	Description	Remark
1	1	30 300	Rear plate, complete	State serial No.
2	1	40 237	Rear plate	State serial No.
3	1	816 805	Spring	
4	1	816 804	Spring	
5	1	13 125	Light trap	
6	2	821 203	Screw	
7	2	13 397	Foam plastic strip	
8	4	810503	Washer (0.10 mm)	For adjustment 810 505 (0.20 mm)
9	4	840 514	Hub	
10	4	825 661	Screw	
11	1	30 770	Mirror frame	Incl. reflection protector 22 874
12	1	22 419	Reflection protector	
13	1	90 711	Top flap	
14	1	90 712	Bottom flap	
15	1	22 420	Reflection protector	
16	2	13 185	Lever	
17	2	811 108	Pin	
18	1	13 100	Connecting rod	
19	1	13 101	Connecting rod	
20	1	22 423	Magazine hook	
21	2	823 640	Screw	
22	1	22 775	Mirror	
23	1	22 776	Light trap	
24	1	22 804	Spring	
25	1	22 819	Magnet	
26	1	22 878	Arm	Incl. reflection protector 22 875
27	1	810 649	Washer	
28	1	22 800	Sleeve	
29	3	817 115	Clip	
30	1	22 779	Driving arm	
31	1	22 875	Reflection protector	
32	1	22 874	Reflection protector	

Camera body 503CW

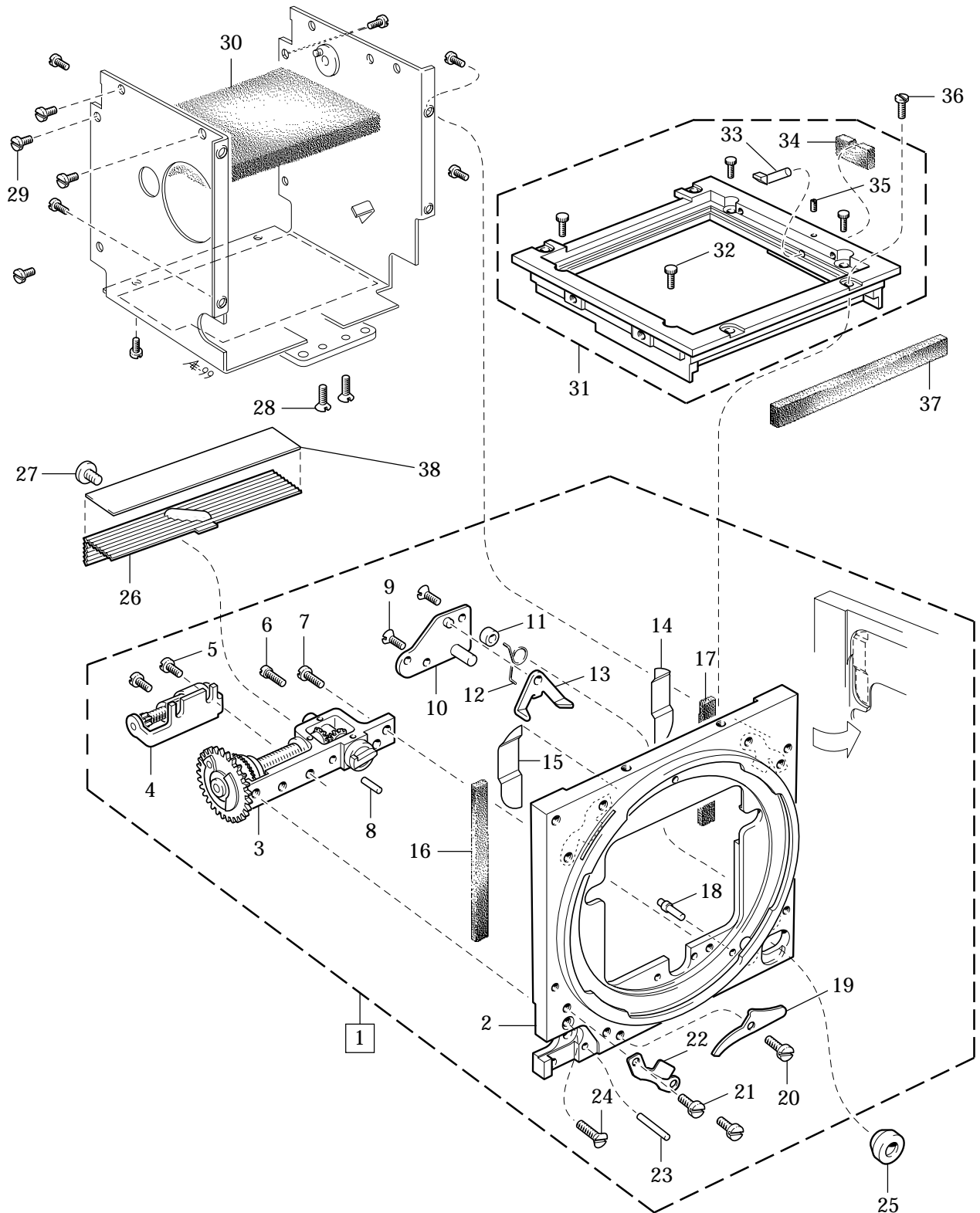

# H A S S E L B L A D

## Camera body 503CW

# 11

Pos No.	Pcs	Spare Part No.	Description	Remark
1	1	30 777	Front bayonet plate	Complete
2	1	40 403	Front bayonet plate	
3	1	30 383	Front gear	
4	1	30 386	Governor	
5	2	820 014	Screw	
6	1	821 009	Screw	
7	1	820 018	Screw	
8	1	812 202	Pin	
9	2	823 440	Screw	
10	1	105 107	Cover plate	
11	1	810 409	Spacer	Replaced by p/n 22850, page 7
12	1	816 858	Spring	
13	1	103 440	Lens catch	
14	1	22 832	Foil, left	
15	1	22 829	Foil, right	
16	1	13 213	Foam plastic strip	
17	1	13 212	Foam plastic strip	
18	1	836 107	Stop pin	
19	1	21 096	Plate spring	
20	1	820 015	Screw	
21	8	820 425	Screw	Incl. reflection protector 22 873
22	4	103 439	Bayonet flange	
23	1	812 213	Pin	
24	1	823 019	Screw	
25	1	103 773	Teflon button	
26	1	22 876	Cover	
27	1	821 031	Screw	
28	2	823 655	Screw	
29	12	820 015	Screw	
30	1	22 582	Foam plastic pad	
31	1	22 812	Frame, complete	
32	4	21 606	Screw	
33	1	22 467	Light pipe	
34	1	22 655	Foam plastic strip	
35	1	825 420	Screw	
36	4	821 017	Screw	
37	1	22 828	Foam plastic strip	
38	1	22 873	Reflection protector	

Camera body 503CW

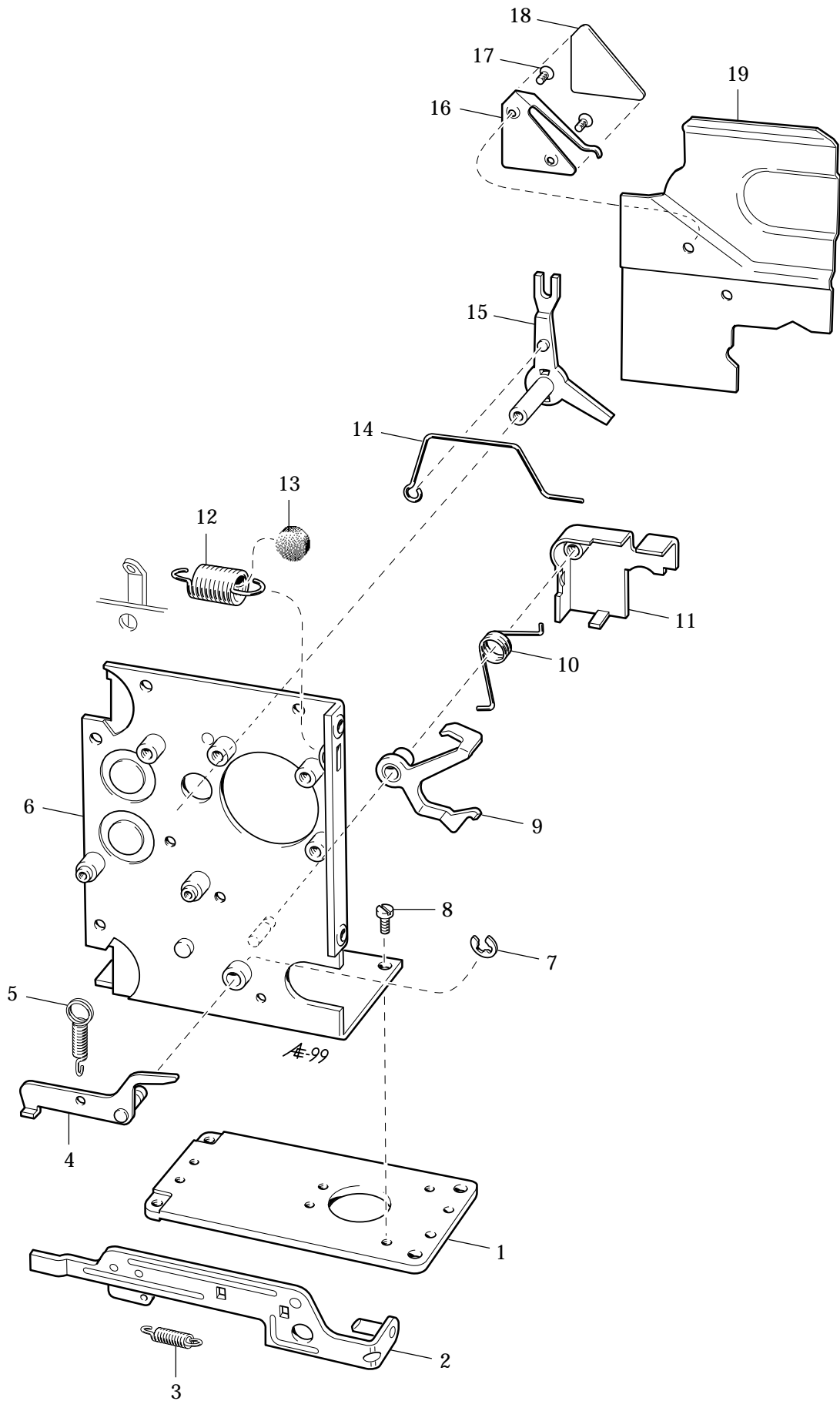

# H A S S E L B L A D

## Camera body 503CW

12

Pos No.	Pcs	Spare Part No.	Description	Remark
1	1	30 686	Bottom plate	
2	1	30 375	Release bar	
3	1	814 512	Spring	
4	1	22 717	Signal arm	
5	1	814 603	Spring	
6	1	21095-01	Inner wall, right	
7	1	817 119	Clip	
8	6	820 014	Screw	
9	1	13 356-01	Mirror catch	
10	1	816 720	Spring	
11	1	30 727	Cover	
12	1	814 827	Spring	
13	1	22 532	Rubber plug	
14	1	13 280	Lens lock	
15	1	13 362	Mirror lever	
16	1	30 775	Spring	
17	2	829 425	Screw	
18	1	22 872	Reflection protector	
19	1	22 813	Cover	

# Camera body 503CW

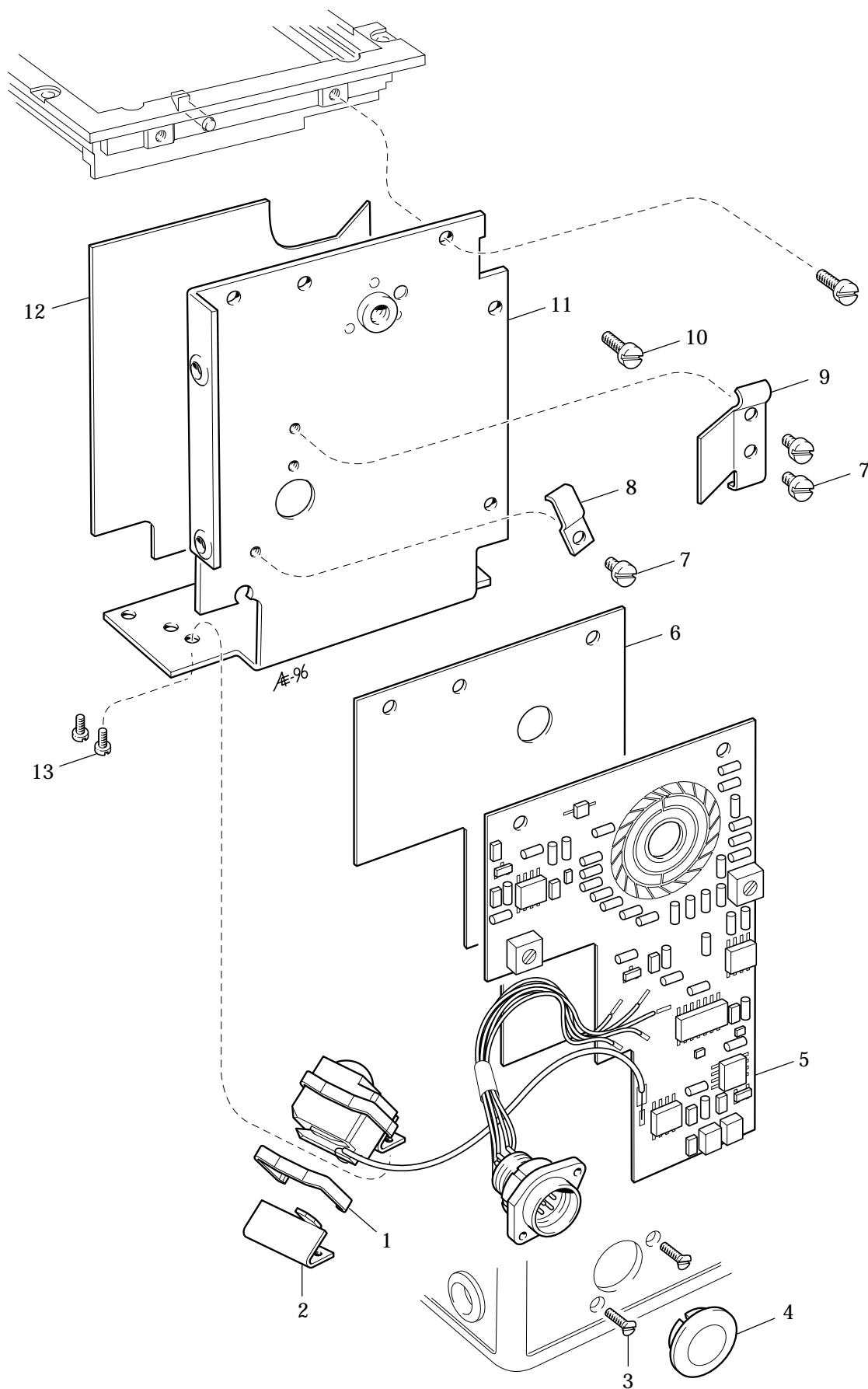



# H A S S E L B L A D

## Camera body 503CW

# 13

Pos No.	Pcs	Spare Part No.	Description	Remark
1	1	22 577	Clip	See below
2	1	22576	Bracket	
3	2	823 335	Screw	
4	1	22 470	Socket cap	
5	1	22 575	PC board	
6	1	22 746	Insulating plate	
7	3	820 011	Screw	
8	1	12 453	Cable holder	
9	1	22 453	Attachment	
10	2	820 015	Screw	
11	1	40 397	Inner wall, left	
12	1	22 815	Reflection protector	
13	2	820 325	Screw	
		22 882	PC board (incl. tape)	From camera serial No. 19ER18271 See Service Info 12/98
		22 879	Double-sided tape	

Camera body 503CW

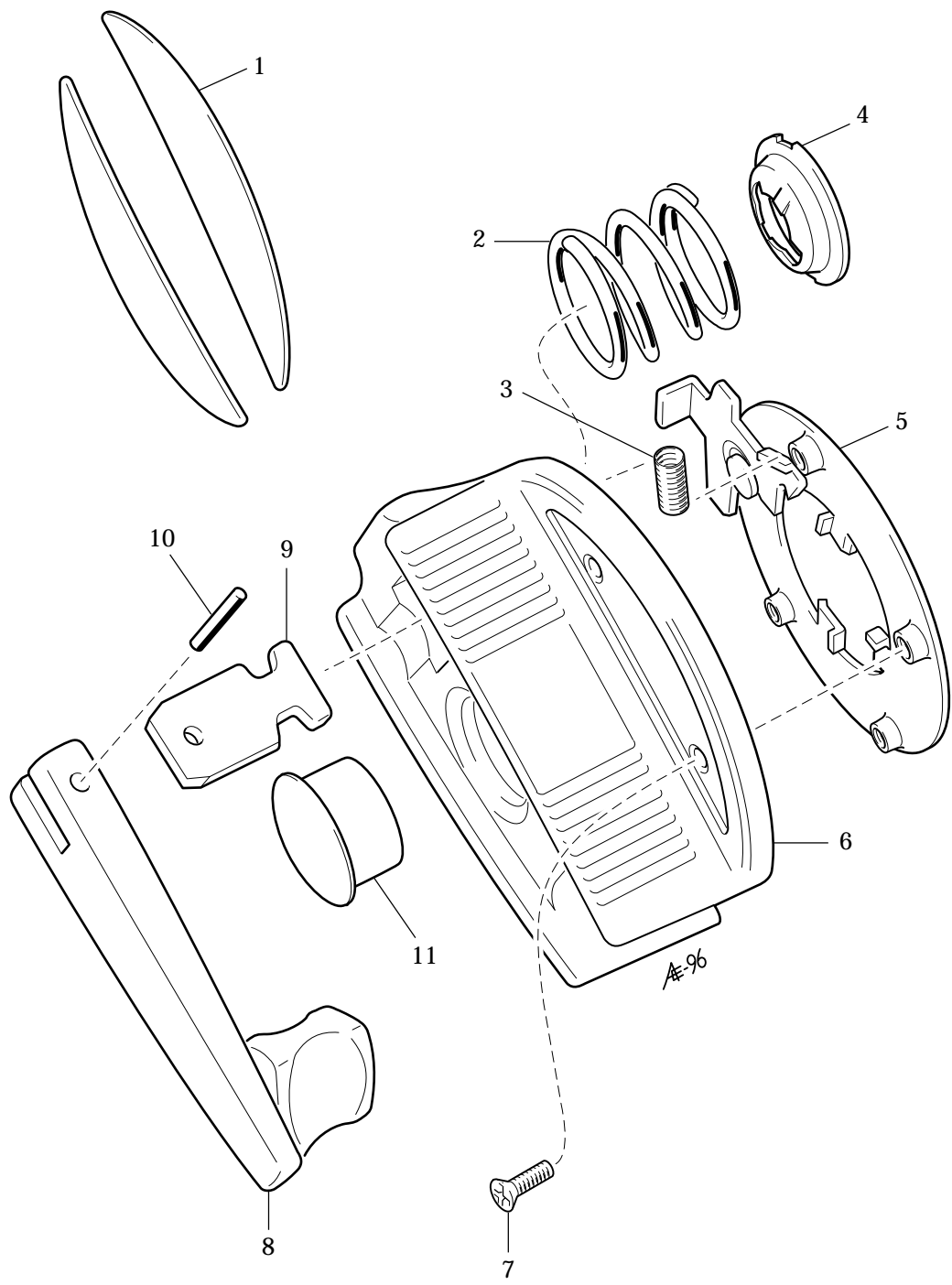

**H A S S E L B L A D**  
**Camera body 503CW**

**14**

<b>Pos No.</b>	<b>Pcs</b>	<b>Spare Part No.</b>	<b>Description</b>	<b>Remark</b>
1	2	103 517	Leather	
2	1	815 904	Spring	
3	1	815 707	Spring	
4	1	103 516	Washer	
5	1	103 113	Crank bayonet	
6	1	107 409	Crank support	
7	4	829 540	Screw	
8	1	103 151	Crank arm	
9	1	103 514	Slide	
10	1	812 301	Pin	
11	1	22 683	Rubber plug	

# Camera body 501C

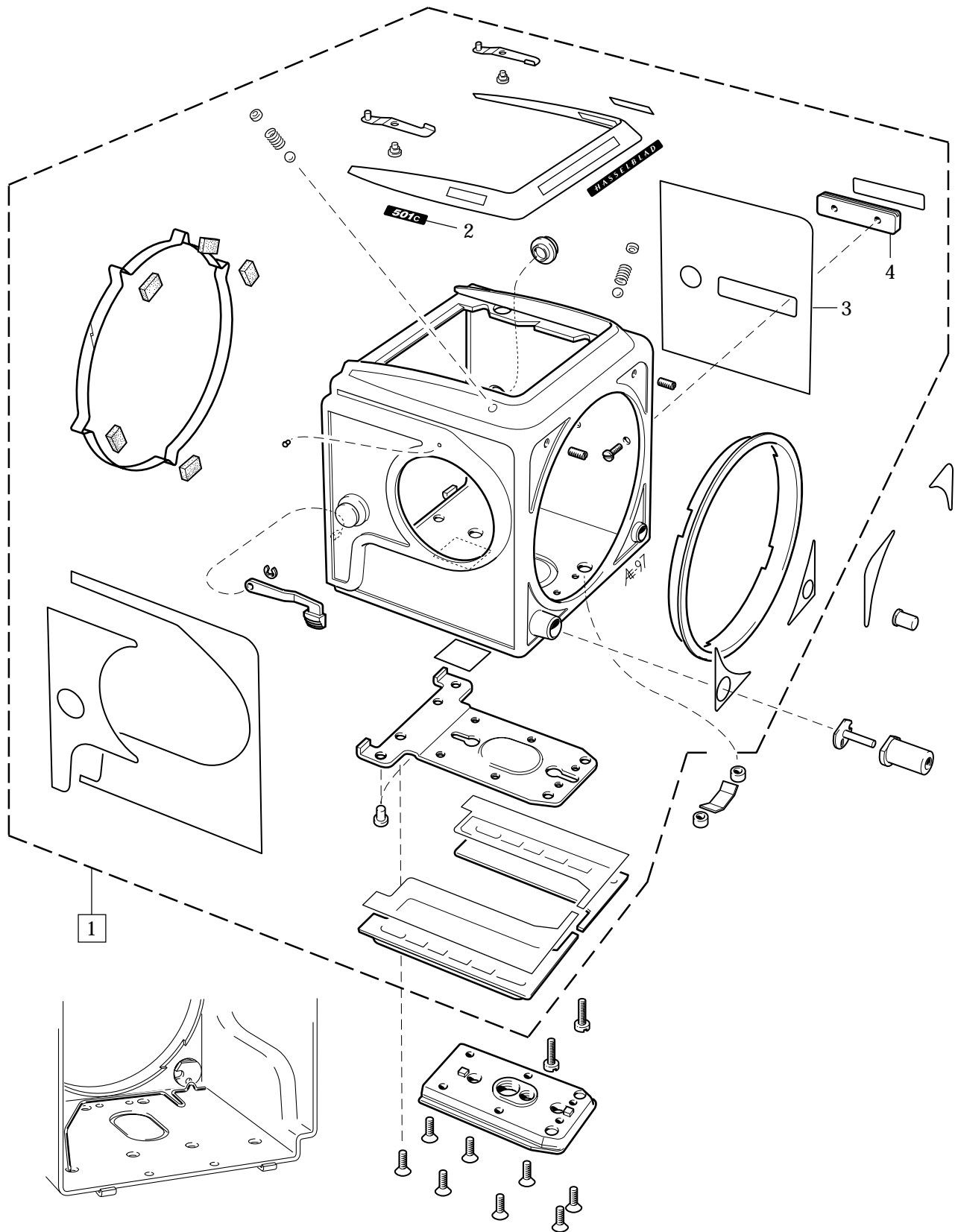

**H A S S E L B L A D**  
**Camera body 501C**

**15:1**

<b>Pos No.</b>	<b>Pcs</b>	<b>Spare Part No.</b>	<b>Description</b>	<b>Remark</b>
1	1	40 384	Shell, complete	
2	2	22 782	Name plate	
3	1	103 592	Leather	
4	1	103 529	Accessory rail	

**Spare parts not listed are the same as for 503CW**

Camera body 501C

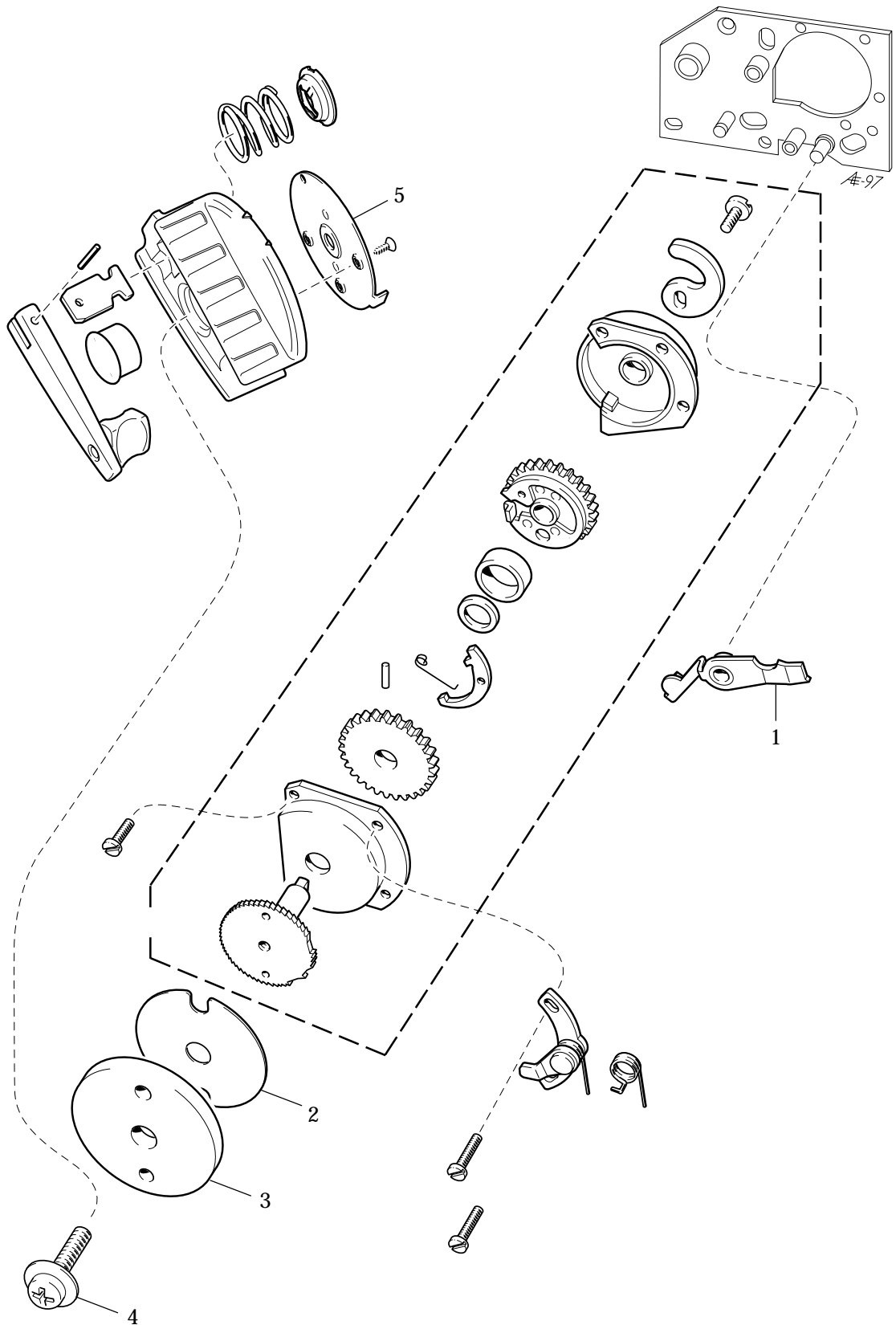

# H A S S E L B L A D

## Camera body 501C

# 15:2

Pos No.	Pcs	Spare Part No.	Description	Remark
1	1	13 355	Stop lever	
2	1	22 799	Washer	Alternatively none or 1 pc
3	1	412 401	Spacer	
4	1	830 061	Screw	
5	1	412 103	Coupling	New type of winding crank from camera serial No.17EU10379

Spare parts not listed are the same as for 503CW

# Camera body 501C

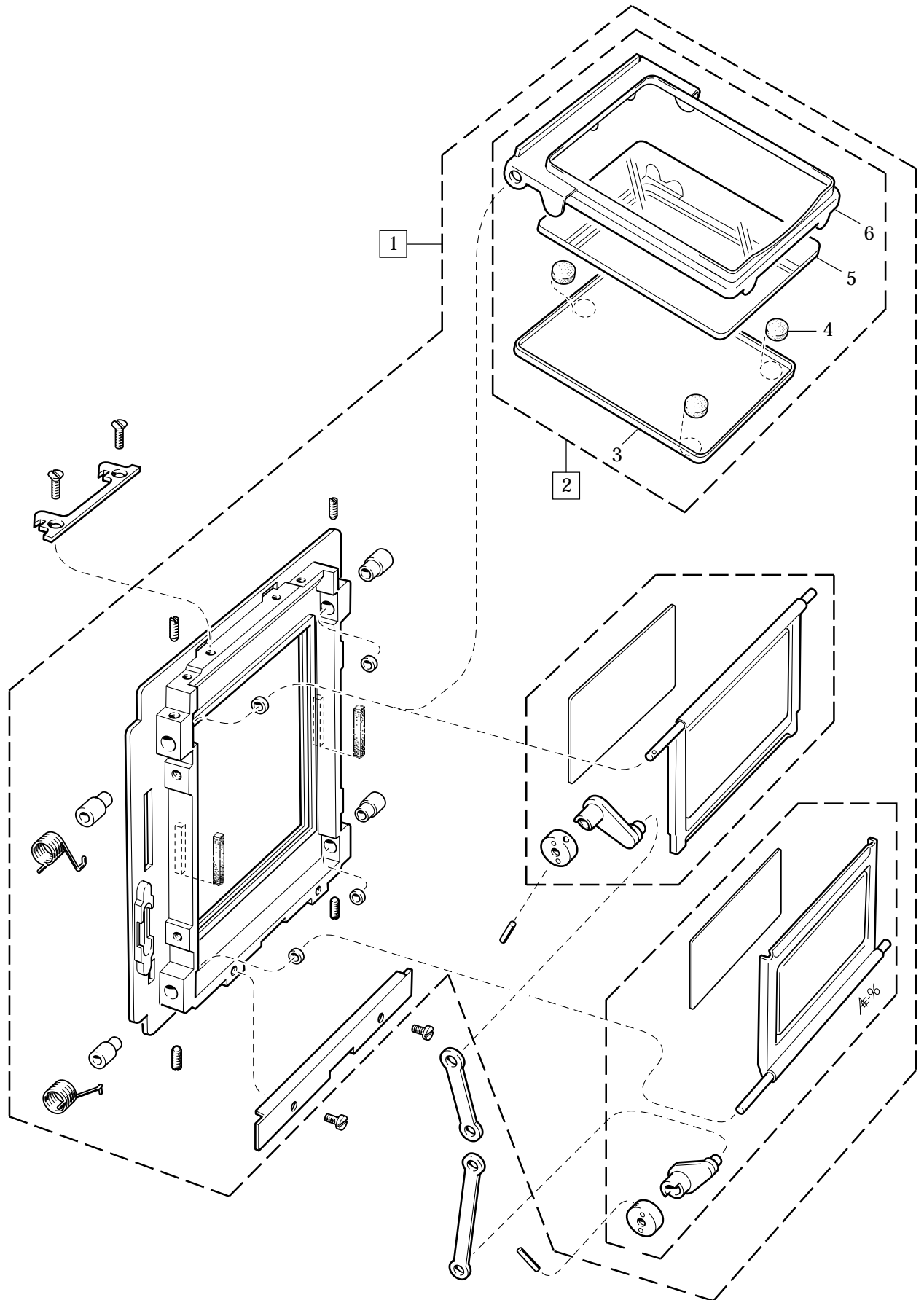



**H A S S E L B L A D**  
**Camera body 501C**

**15:3**

<b>Pos No.</b>	<b>Pcs</b>	<b>Spare Part No.</b>	<b>Description</b>	<b>Remark</b>
1	1	30 519-3	Rear plate, complete	State serial No.
2	2	20 958	Mirror assembly	
3	1	20 901	Mirror protection	
4	3	13 141	Foam plastic pad	
5	1	20 854	Mirror	
6	1	20 956	Frame	

**Spare parts not listed are the same as for 503CW**

## Camera body 501C

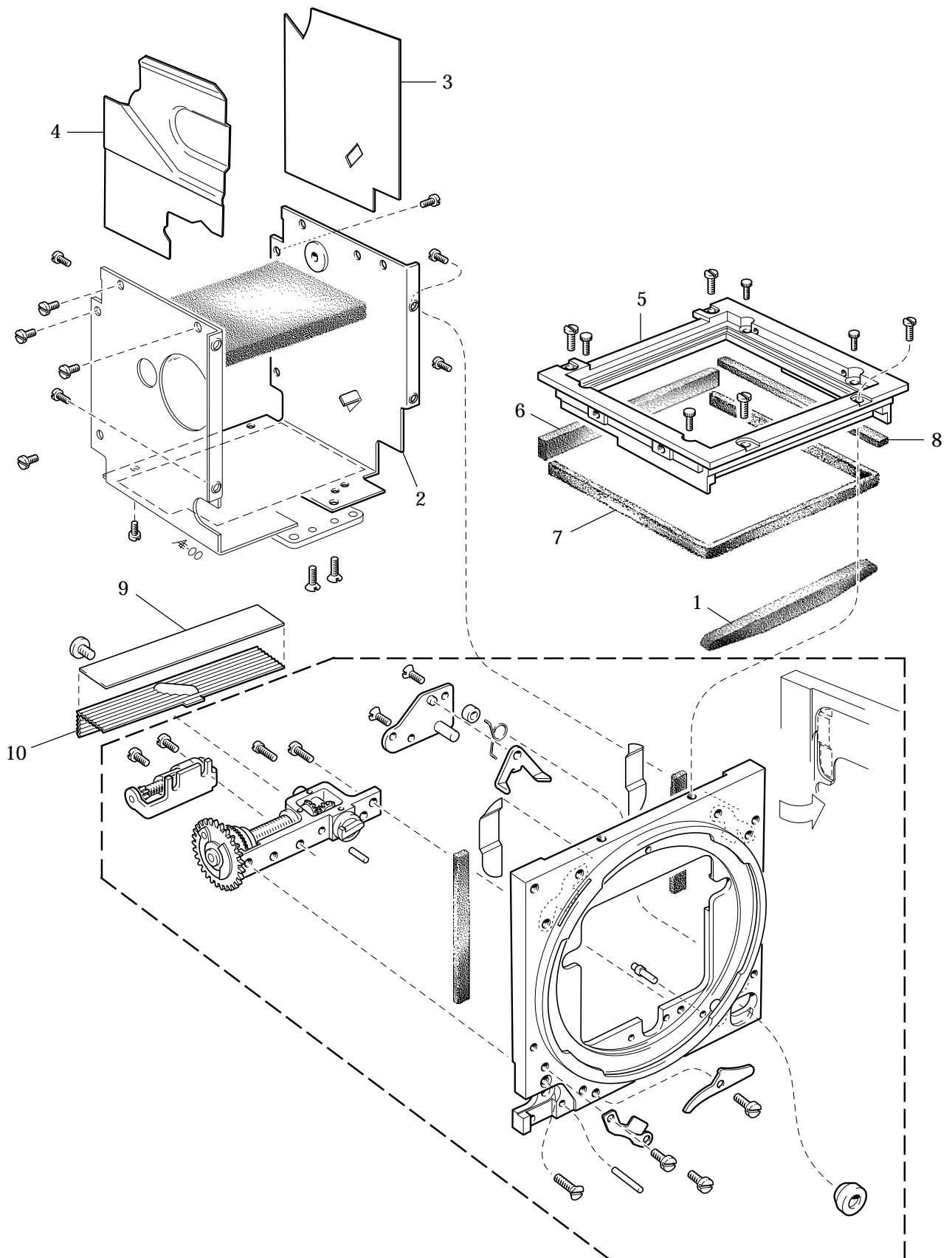

**H A S S E L B L A D**  
**Camera body 501C**

**15:4**

<b>Pos No.</b>	<b>Pcs</b>	<b>Spare Part No.</b>	<b>Description</b>	<b>Remark</b>
1	1	22 422	Foam plastic strip	
2	1	20 959	Inner wall, left	
3	1	22 580	Reflection protector	
4	1	22 598	Cover	
5	1	21 611-1	Frame, complete	Incl. light seals
6	1	13 351	Foam plastic strip	
7	1	13 211	Foam plastic strip	
8	1	22 429	Foam plastic strip	
9	1	22 873	Reflection protector	
10	1	22 892	Cover	Incl. reflection protector 22 873

**Spare parts not listed are the same as for 503CW**

Camera body 501C

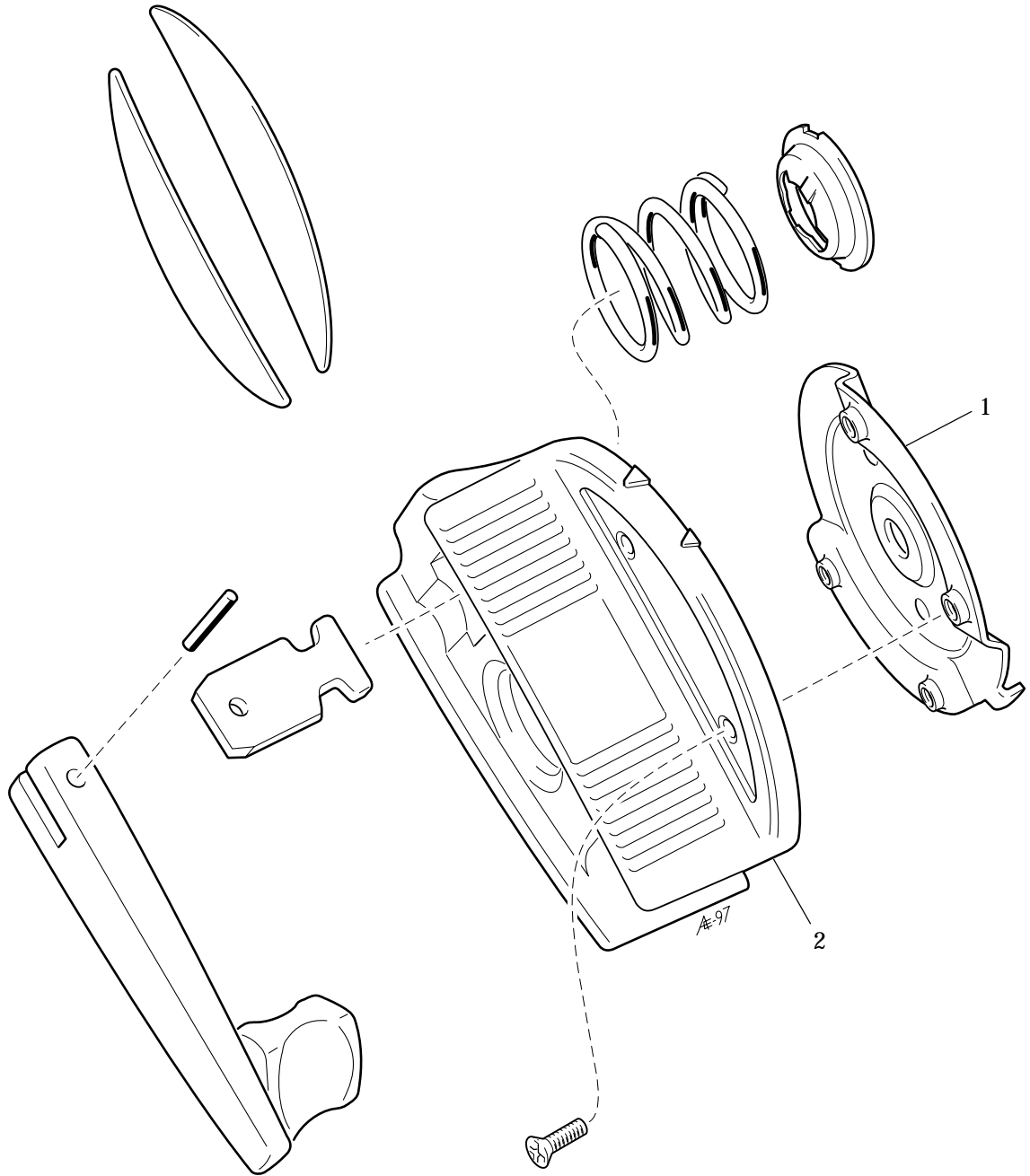

**H A S S E L B L A D**  
**Camera body 501C**

**15:5**

<b>Pos No.</b>	<b>Pcs</b>	<b>Spare Part No.</b>	<b>Description</b>	<b>Remark</b>
1	1	22 750	Coupling	
2	1	22 751	Crank support	

**Spare parts not listed are the same as for 503CW**

Camera body 503CXi

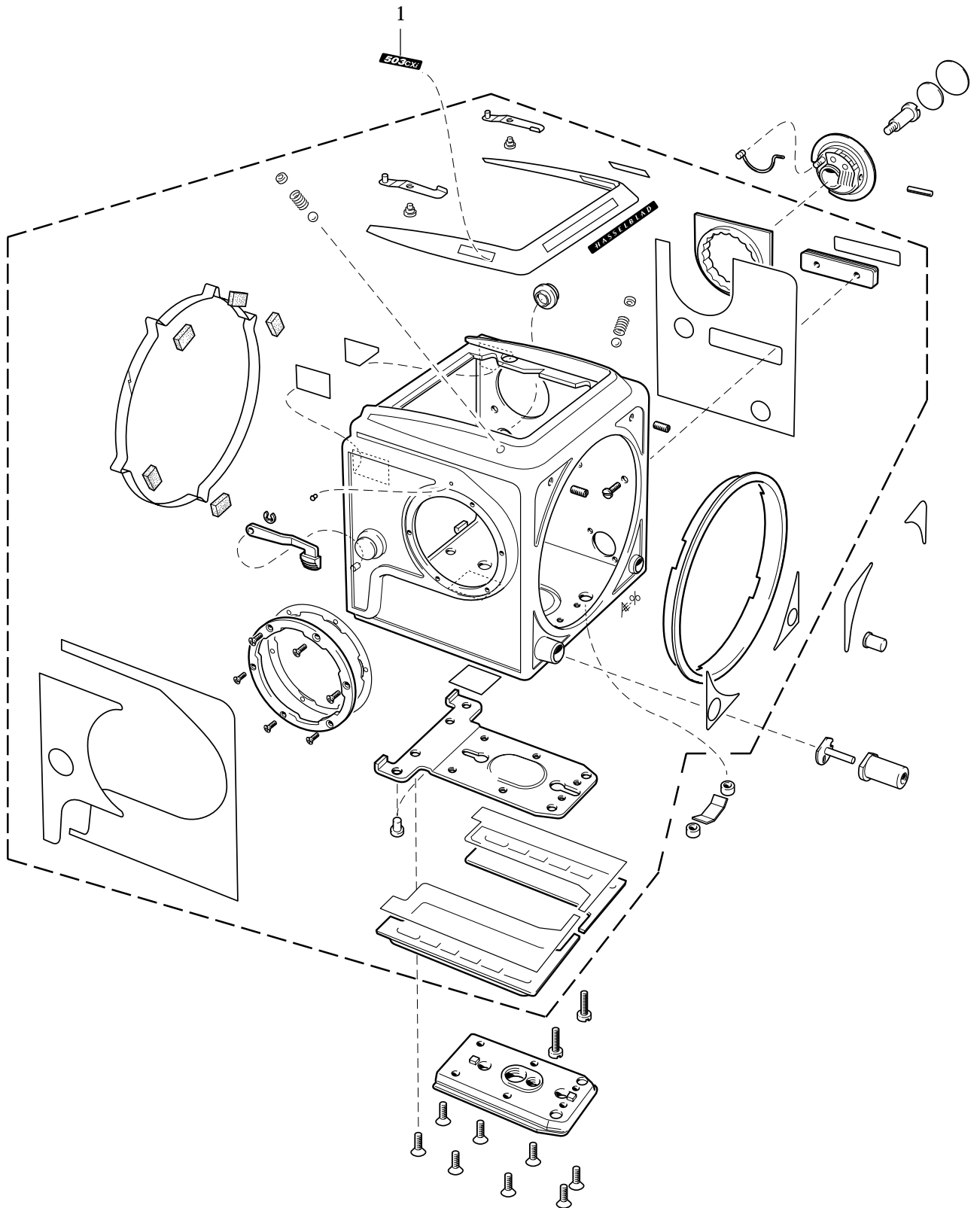

**H A S S E L B L A D**  
**Camera body 503CXi**

**16:1**

<b>Pos No.</b>	<b>Pcs</b>	<b>Spare Part No.</b>	<b>Description</b>	<b>Remark</b>
1	2	22 771	Name plate	

**Spare parts not listed are the same as for 503CW**

# Camera body 503CXi

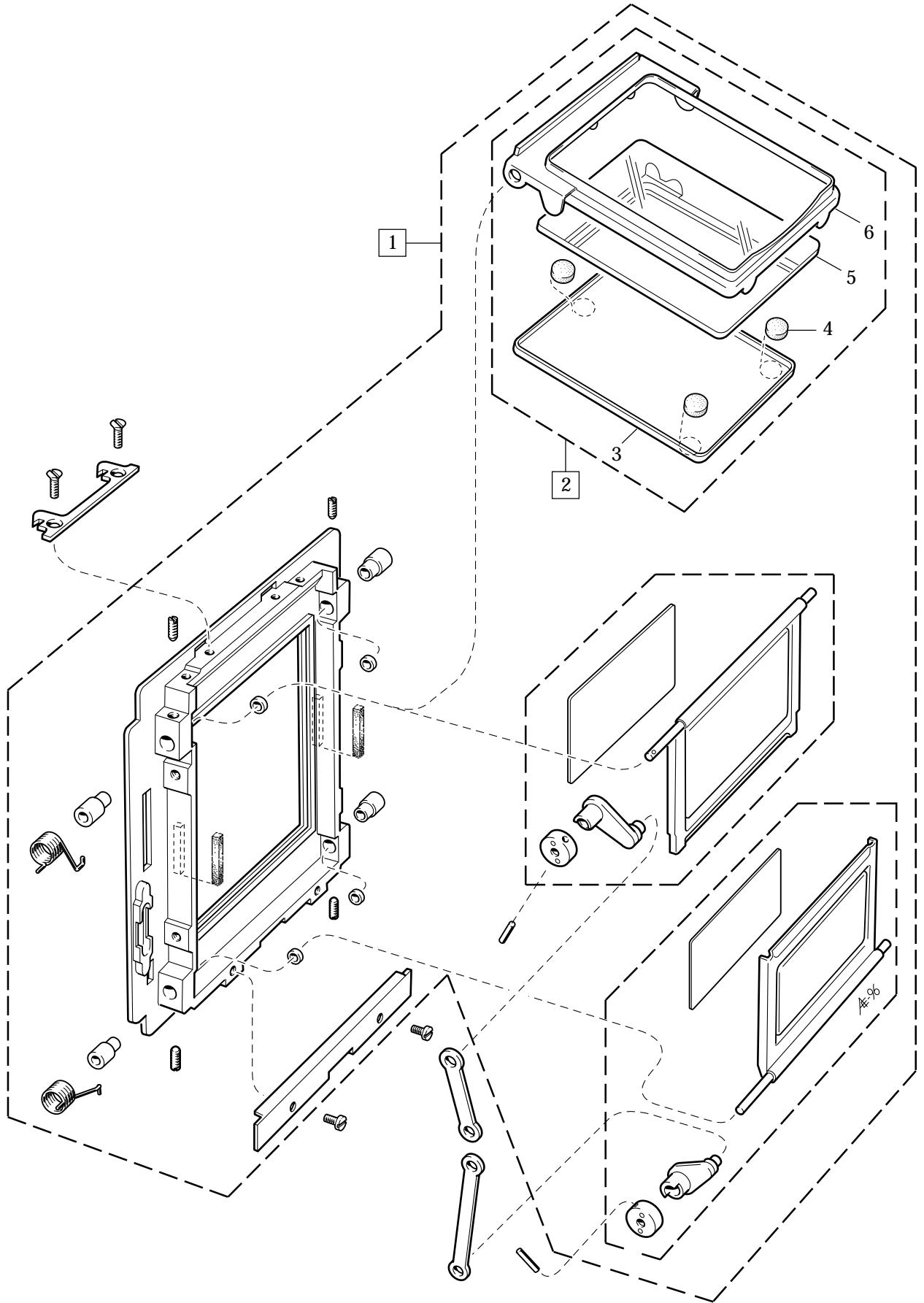



**H A S S E L B L A D**  
**Camera body 503CXi**

**16:2**

<b>Pos No.</b>	<b>Pcs</b>	<b>Spare Part No.</b>	<b>Description</b>	<b>Remark</b>
1	1	30 519	Rear plate, complete	State serial No.
2	2	20 958	Mirror assembly	
3	1	20 901	Mirror protection	
4	3	13 141	Foam plastic pad	
5	1	20 854	Mirror	
6	1	20 956	Frame	

**Spare parts not listed are the same as for 503CW**

Camera body 503CXi

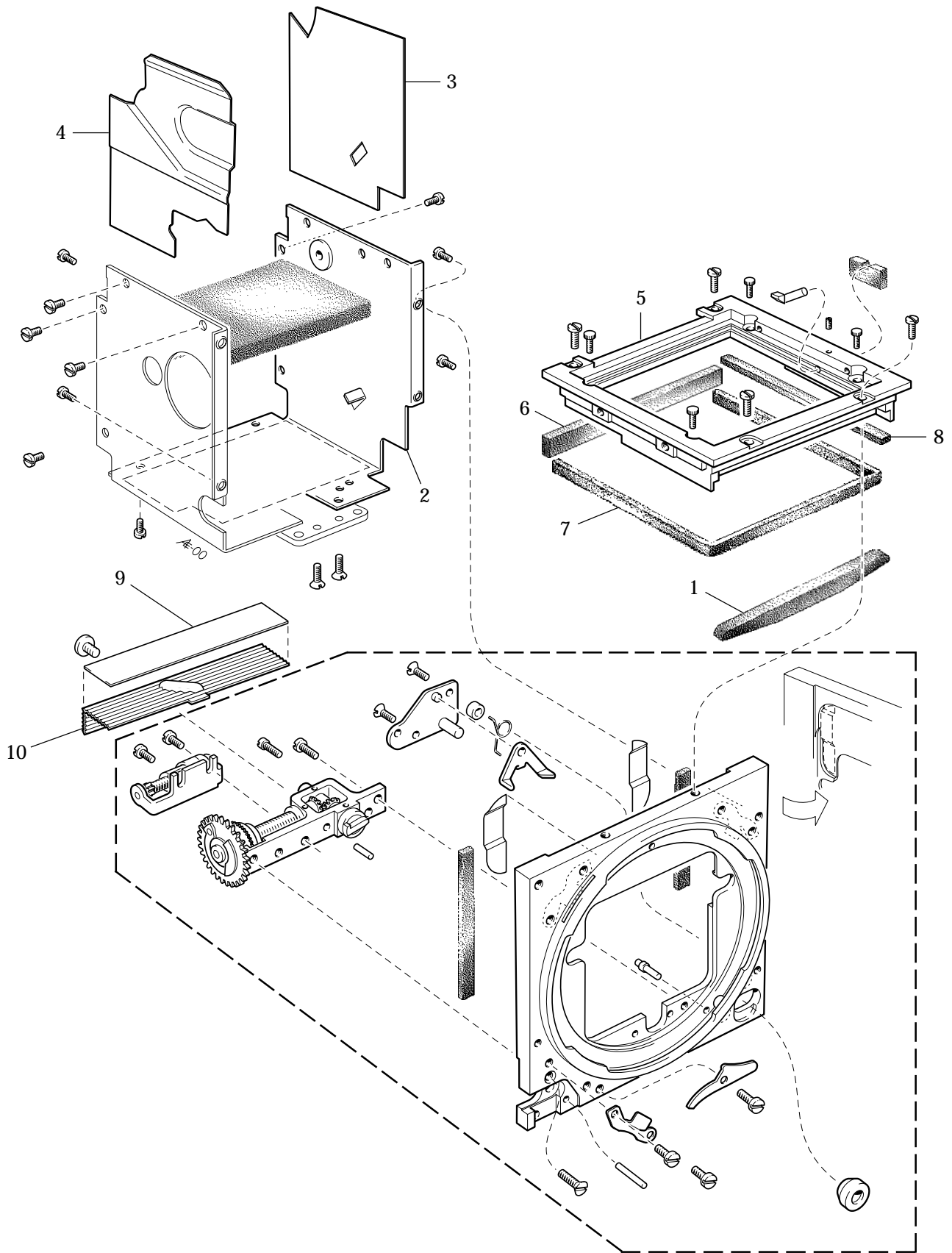

**H A S S E L B L A D**  
**Camera body 503CXi**

**16:3**

<b>Pos No.</b>	<b>Pcs</b>	<b>Spare Part No.</b>	<b>Description</b>	<b>Remark</b>
1	1	22 422	Foam plastic strip	
2	1	20 959	Inner wall, left	
3	1	22 580	Reflection protector	
4	1	22 598	Cover	
5	1	21 611-01	Frame, complete	Incl. light seals
6	1	13 351	Foam plastic strip	
7	1	13 211	Foam plastic strip	
8	1	22 429	Foam plastic strip	
9	1	22 873	Reflection protector	
10	1	22 876	Cover	Incl. reflection protector 22 873

**Spare parts not listed are the same as for 503CW**

# Camera body 503CX

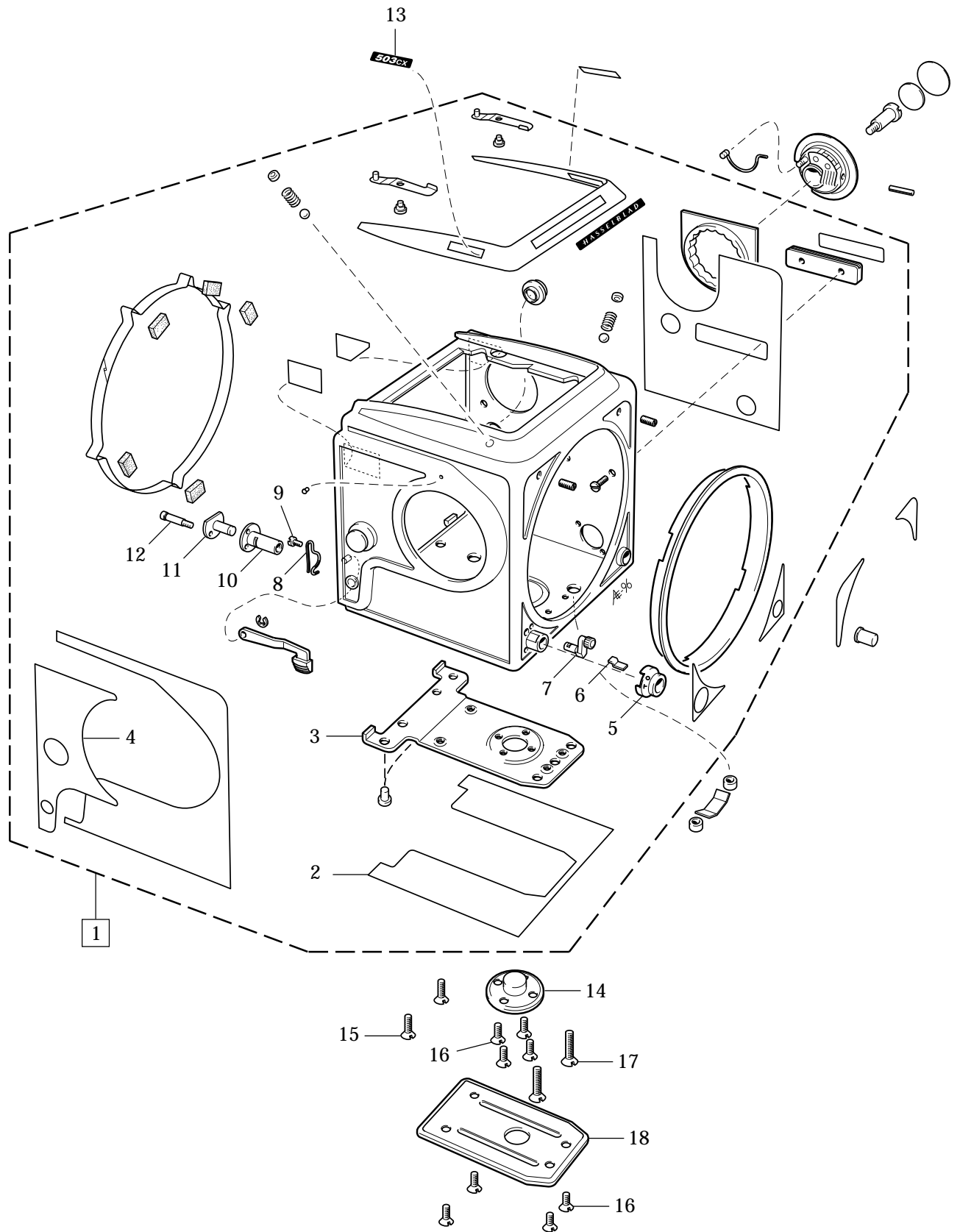

**H A S S E L B L A D**  
**Camera body 503CX**

**17:1**

<b>Pos No.</b>	<b>Pcs</b>	<b>Spare Part No.</b>	<b>Description</b>	<b>Remark</b>
1	1	40 346	Shell, complete (chrome)	Part No. 40347 (black)
2	1	103 506	Leather	
3	1	103 327	Support	
4	1	103 503	Leather	
5	1	20 948	Socket	
6	1	13 418	Plate spring	
7	1	13 417	T-arm	
8	1	816 759	Spring	
9	1	821 206	Screw	
10	1	13 134	Release button	
11	1	22 367	Buffer	Standard Optional
12	1	13 137	Screw	
13	2	22 608	Name plate	
14	1	103 846	Tripod socket 1/4"	
	1	402 347	Tripod socket 3/8"	
15	2	824 701	Screw	
16	8	823 735	Screw	
17	2	823 781	Screw	
18	1	103 349	Slide	

**Spare parts not listed are the same as for 503CW**

# Camera body 503CX

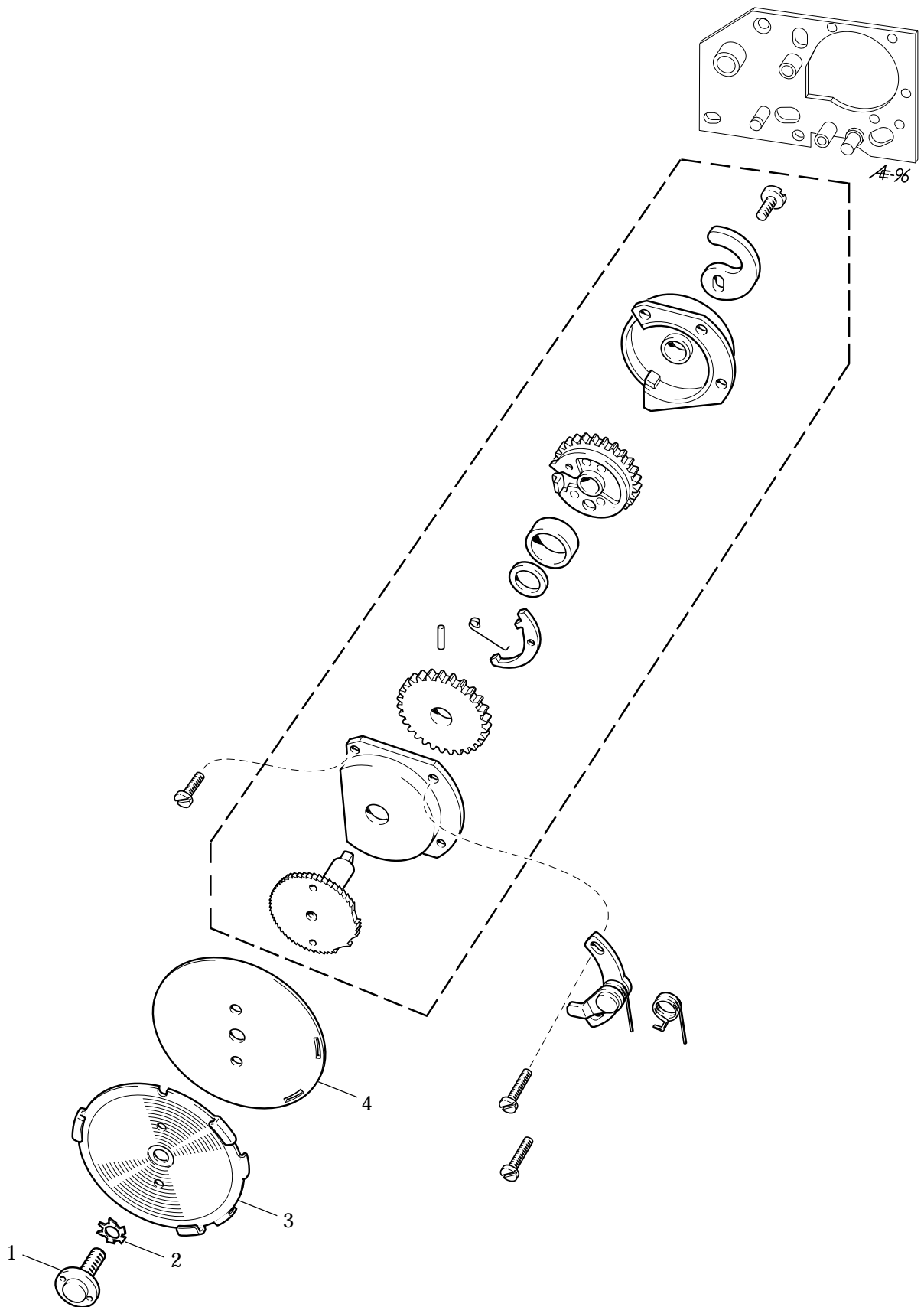

**H A S S E L B L A D**  
**Camera body 503CX**

**17:2**

<b>Pos No.</b>	<b>Pcs</b>	<b>Spare Part No.</b>	<b>Description</b>	<b>Remark</b>
1	1	821 806	Screw	For adjustment 13360-01, 0.4 mm
2	1	13 436	Locking washer	
3	1	13 163	Bayonet plate	
4	1	13 360	Shim, 0.2 mm	

**Spare parts not listed are the same as for 503CW**

# Camera body 503CX

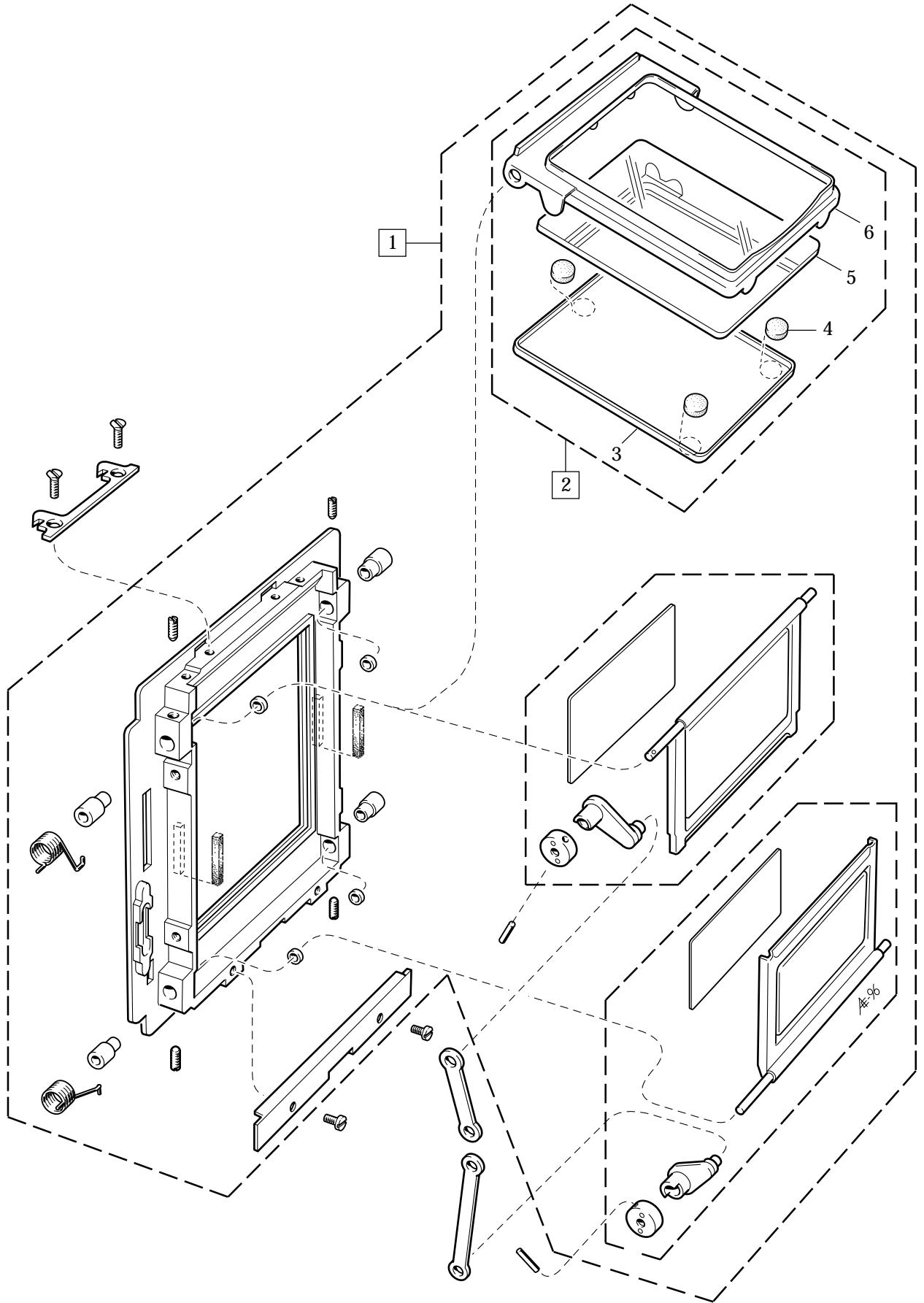



**H A S S E L B L A D**  
**Camera body 503CX**

**17:3**

<b>Pos No.</b>	<b>Pcs</b>	<b>Spare Part No.</b>	<b>Description</b>	<b>Remark</b>
1	1	30 519	Rear plate, complete	State serial No.
2	2	20 958	Mirror assembly	
3	1	20 901	Mirror protection	
4	3	13 141	Foam plastic pad	
5	1	20 854	Mirror	
6	1	20 956	Frame	

**Spare parts not listed are the same as for 503CW**

# Camera body 503CX

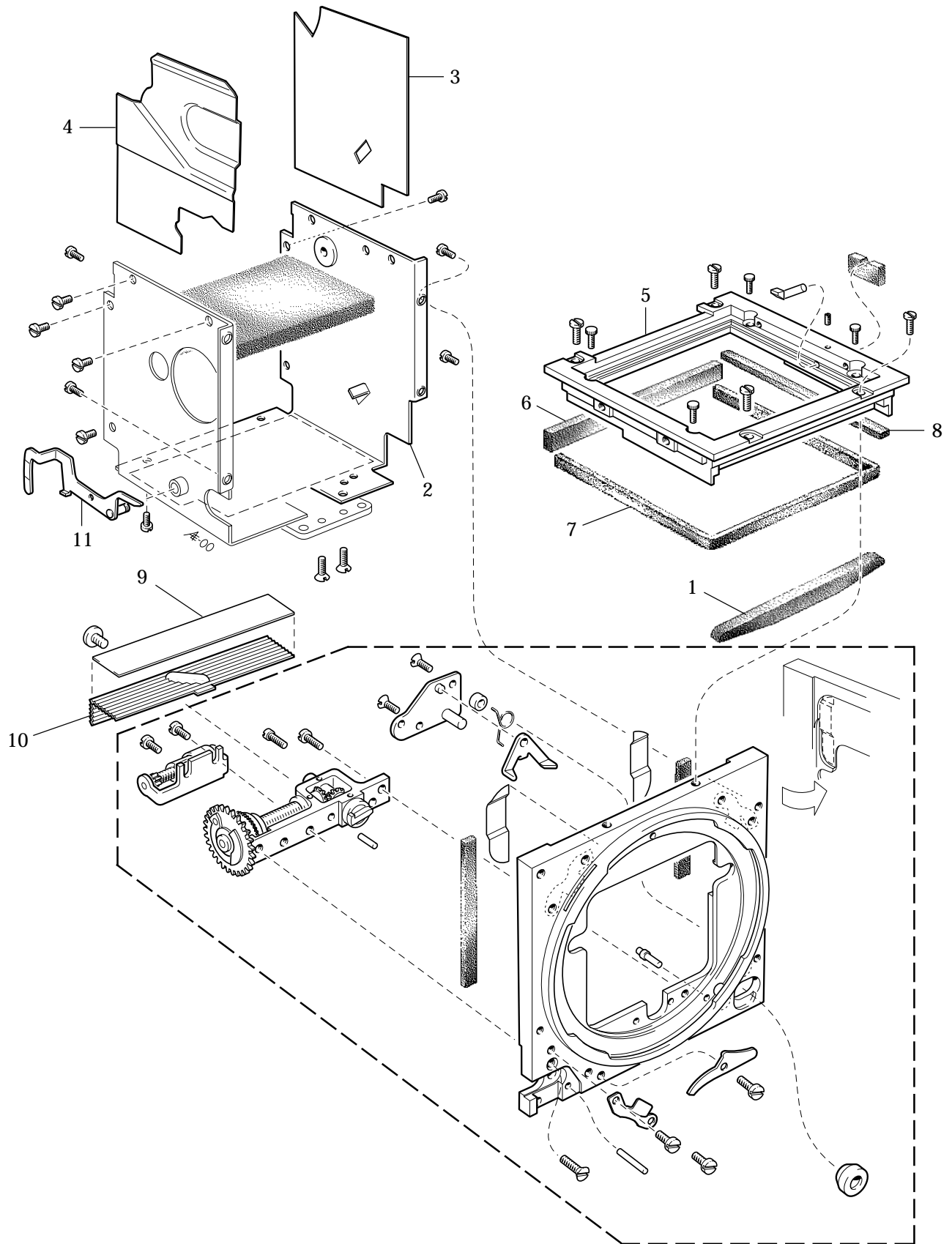

**H A S S E L B L A D**  
**Camera body 503CX**

**17:4**

<b>Pos No.</b>	<b>Pcs</b>	<b>Spare Part No.</b>	<b>Description</b>	<b>Remark</b>
1	1	22 422	Foam plastic strip	
2	1	20 959	Inner wall, left	
3	1	22 580	Reflection protector	
4	1	22 598	Cover	
5	1	21 611-01	Frame, complete	Incl. light seals
6	1	13 351	Foam plastic strip	
7	1	13 211	Foam plastic strip	
8	1	22 429	Foam plastic strip	
9	1	22 873	Reflection protector	
10	1	22 876	Cover	Incl. reflection protector 22 873
11	1	13 220	Signal arm	Mounted on the right inner wall

**Spare parts not listed are the same as for 503CW**

# Camera body 503CX

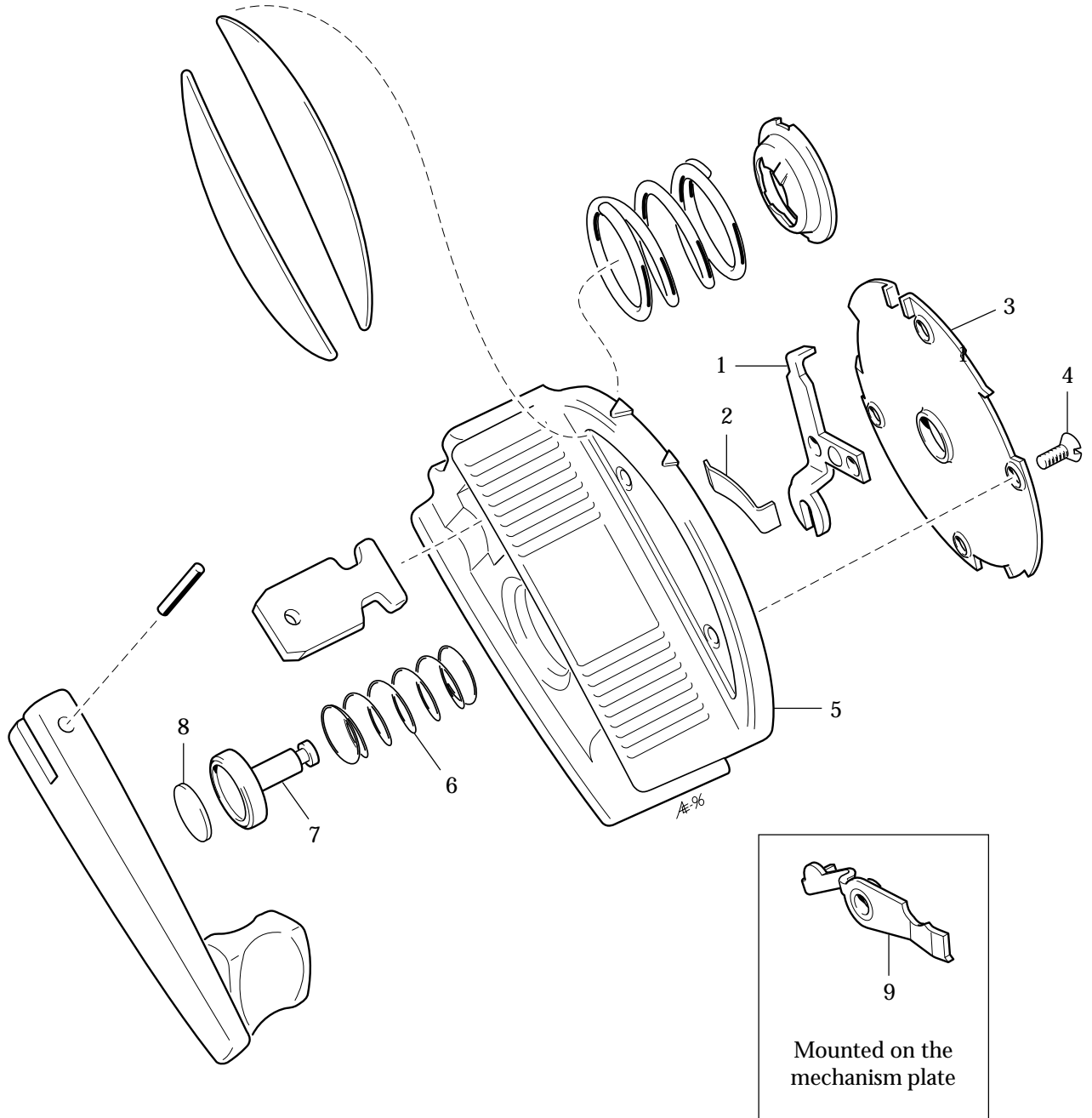

**H A S S E L B L A D**  
**Camera body 503CX**

**17:5**

<b>Pos No.</b>	<b>Pcs</b>	<b>Spare Part No.</b>	<b>Description</b>	<b>Remark</b>
1	1	402 411	Catch	
2	1	402 412	Spring	
3	1	402 414	Bayonet plate	
4	4	824 602	Screw	
5	1	402 321	Crank support	
6	1	815 856	Spring	
7	1	402 413	Button	
8	1	14 221	Leather	
9	1	13 355	Stop lever	Mounted on the mechanism plate

**Spare parts not listed are the same as for 503CW**

Camera body 500C/M (Classic)

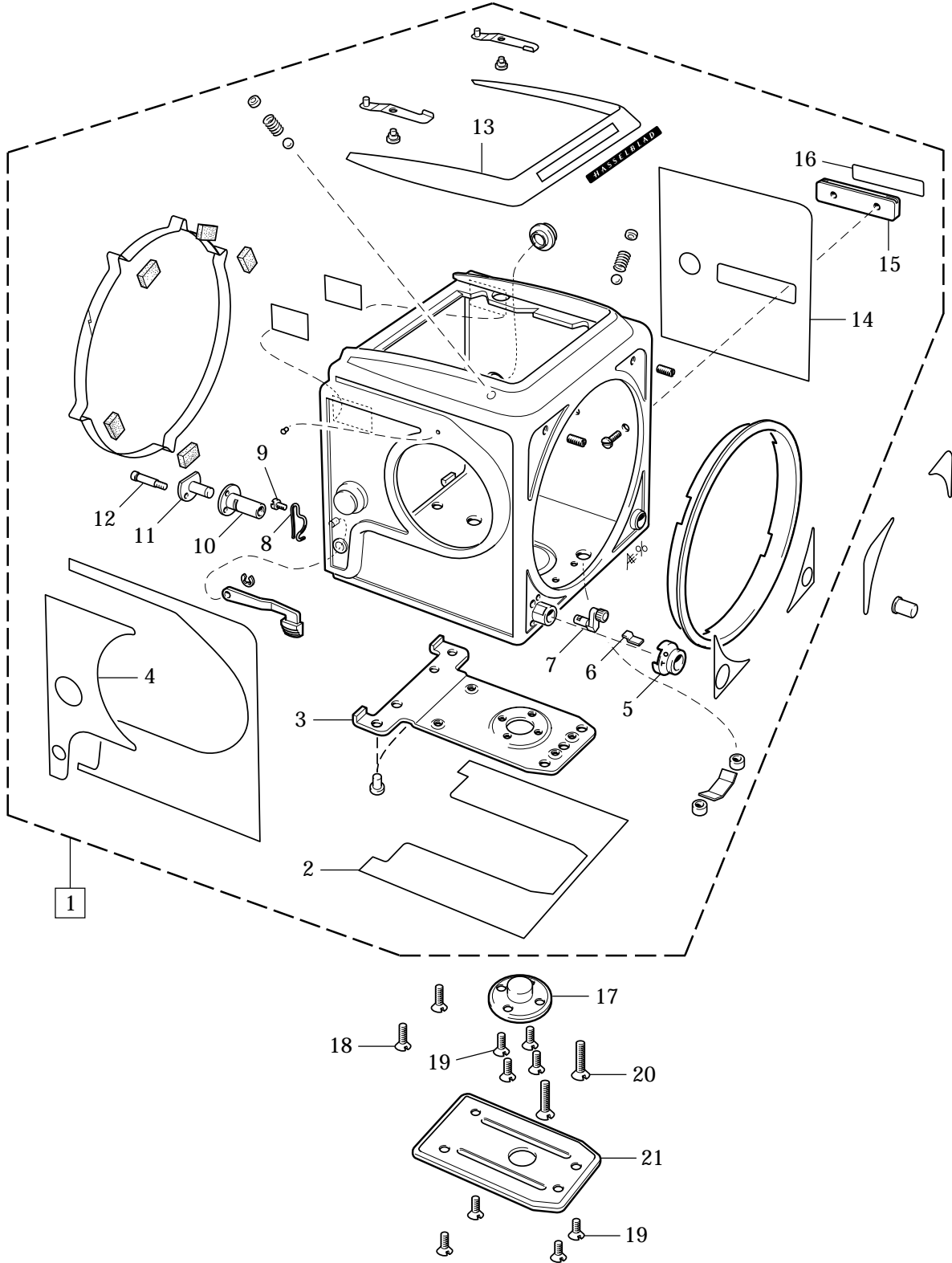

**Camera body 500C/M (Classic)**

<b>Pos No.</b>	<b>Pcs</b>	<b>Spare Part No.</b>	<b>Description</b>	<b>Remark</b>
1	1	40 309	Shell, complete (chrome)	Part No. 40308 (black)
2	1	103 506	Leather	
3	1	103 327	Support	
4	1	103 503	Leather	
5	1	20 948	Socket	
6	1	13 418	Plate spring	
7	1	13 417	T-arm	
8	1	816 759	Spring	
9	1	821 206	Screw	
10	1	13 134	Release button	
11	1	22 367	Buffer	
12	1	13 137	Screw	
13	1	103 511	Leather	
14	1	103 592	Leather	
15	1	103 529	Accessory rail	
16	1	14 188	Name plate	Standard Optional
17	1	402 347	Tripod socket 3/8"	
18	2	824 701	Screw	
19	8	823 735	Screw	
20	2	823 781	Screw	
21	1	103 349	Slide	

**Spare parts not listed are the same as for 503CW**

Camera body 500C/M (Classic)

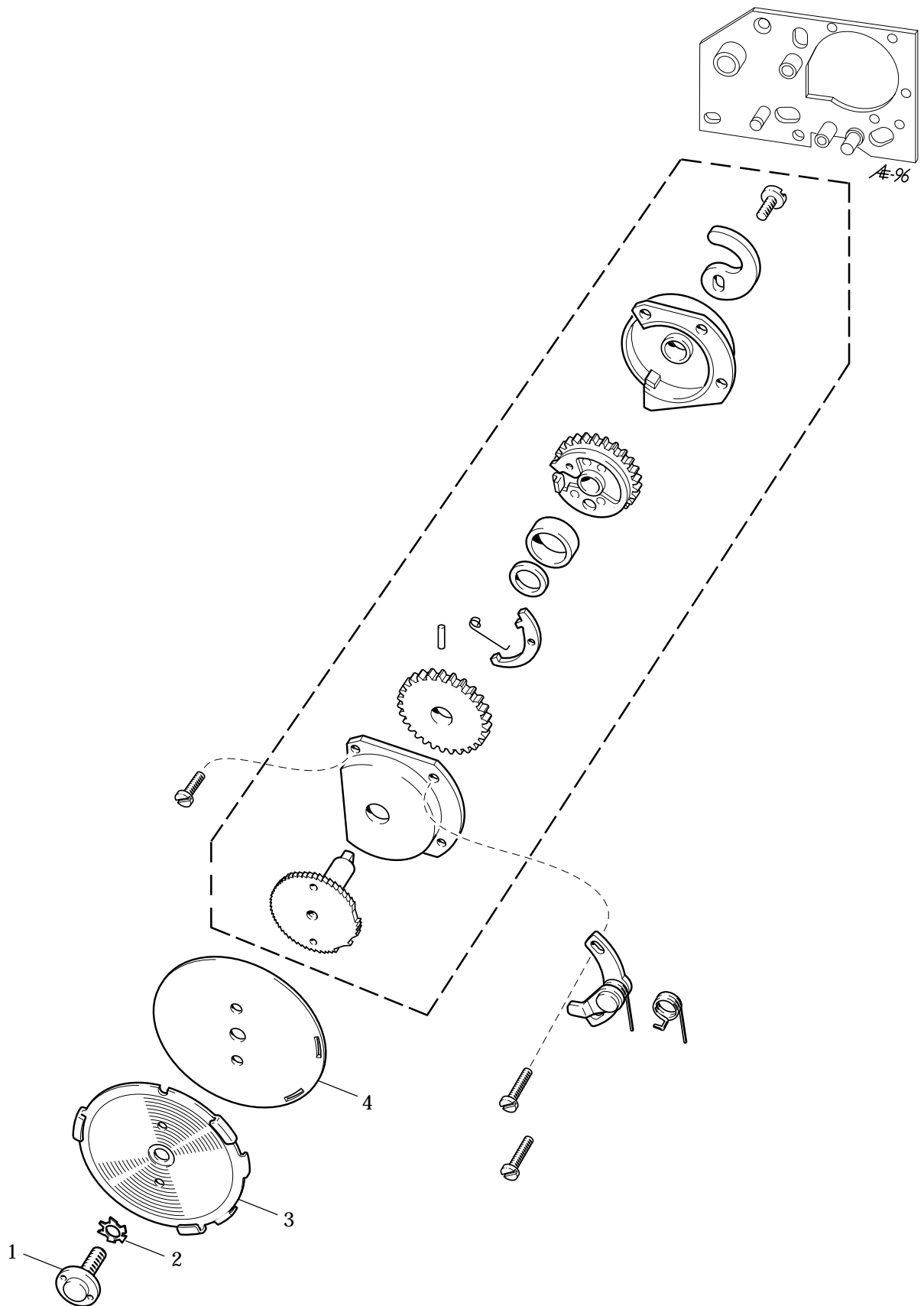



**H A S S E L B L A D**  
**Camera body 500C/M (Classic)**

**18:2**

<b>Pos No.</b>	<b>Pcs</b>	<b>Spare Part No.</b>	<b>Description</b>	<b>Remark</b>
1	1	821 806	Screw	For adjustment 13360-01, 0.4 mm
2	1	13 436	Locking washer	
3	1	13 163	Bayonet plate	
4	1	13 360	Shim, 0.2 mm	

**Spare parts not listed are the same as for 503CW**

Camera body 500C/M (Classic)

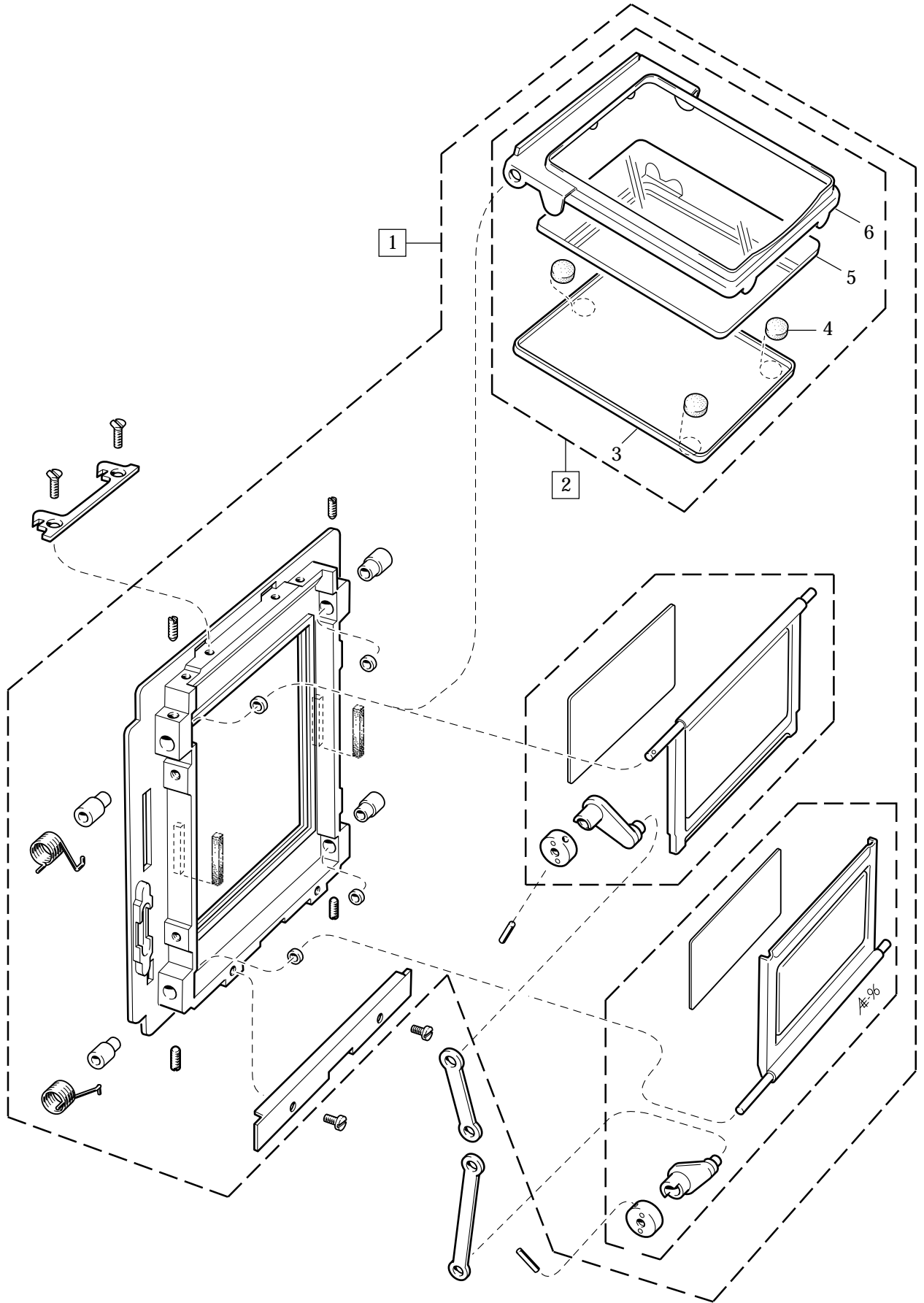

**H A S S E L B L A D**  
**Camera body 500C/M (Classic)**

**18:3**

<b>Pos No.</b>	<b>Pcs</b>	<b>Spare Part No.</b>	<b>Description</b>	<b>Remark</b>
1	1	30 519	Rear plate, complete	State serial No.
2	2	20 958	Mirror assembly	
3	1	20 901	Mirror protection	
4	3	13 141	Foam plastic pad	
5	1	20 854	Mirror	
6	1	20 956	Frame	

**Spare parts not listed are the same as for 503CW**

# Camera body 500C/M (Classic)

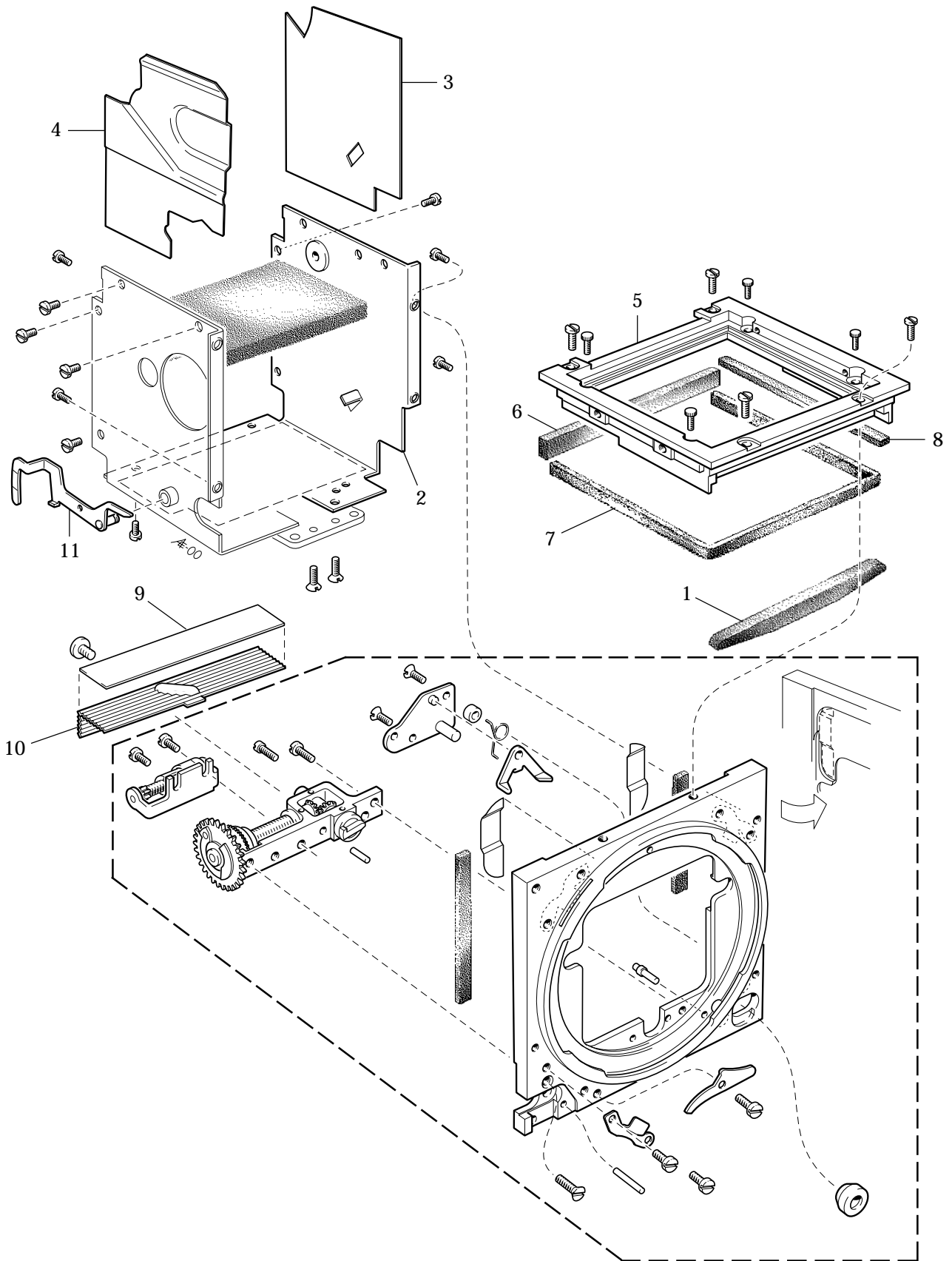

**H A S S E L B L A D**  
**Camera body 500C/M (Classic)**

**18:4**

<b>Pos No.</b>	<b>Pcs</b>	<b>Spare Part No.</b>	<b>Description</b>	<b>Remark</b>
1	1	22 422	Foam plastic strip	
2	1	20 959	Inner wall, left	
3	1	22 580	Reflection protector	
4	1	22 598	Cover	
5	1	21 611-01	Frame, complete	Incl. light seals
6	1	13 351	Foam plastic strip	
7	1	13 211	Foam plastic strip	
8	1	22 429	Foam plastic strip	
9	1	22 873	Reflection protector	
10	1	22 892	Cover	Incl. reflection protector 22 873
11	1	13 220	Signal arm	Mounted on the right inner wall

**Spare parts not listed are the same as for 503CW**

Camera body 500C/M (Classic)

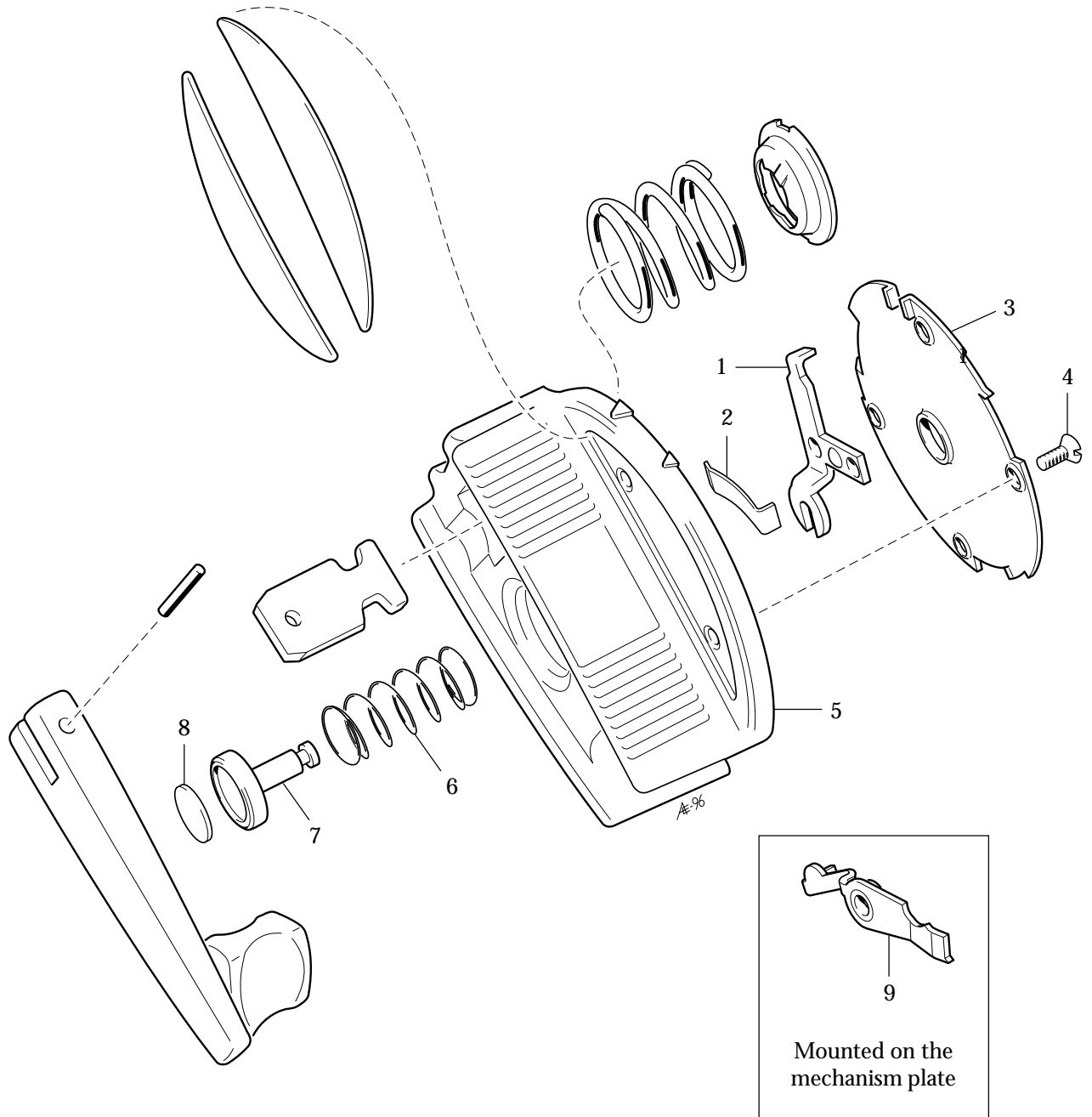

**Camera body 500C/M (Classic)**

<b>Pos No.</b>	<b>Pcs</b>	<b>Spare Part No.</b>	<b>Description</b>	<b>Remark</b>
1	1	402 411	Catch	
2	1	402 412	Spring	
3	1	402 414	Bayonet plate	
4	4	824 602	Screw	
5	1	402 321	Crank support	
6	1	815 856	Spring	
7	1	402 413	Button	
8	1	14 221	Leather	
9	1	13 355	Stop lever	Mounted on the mechanism plate

**Spare parts not listed are the same as for 503CW**

# Camera body 501CM

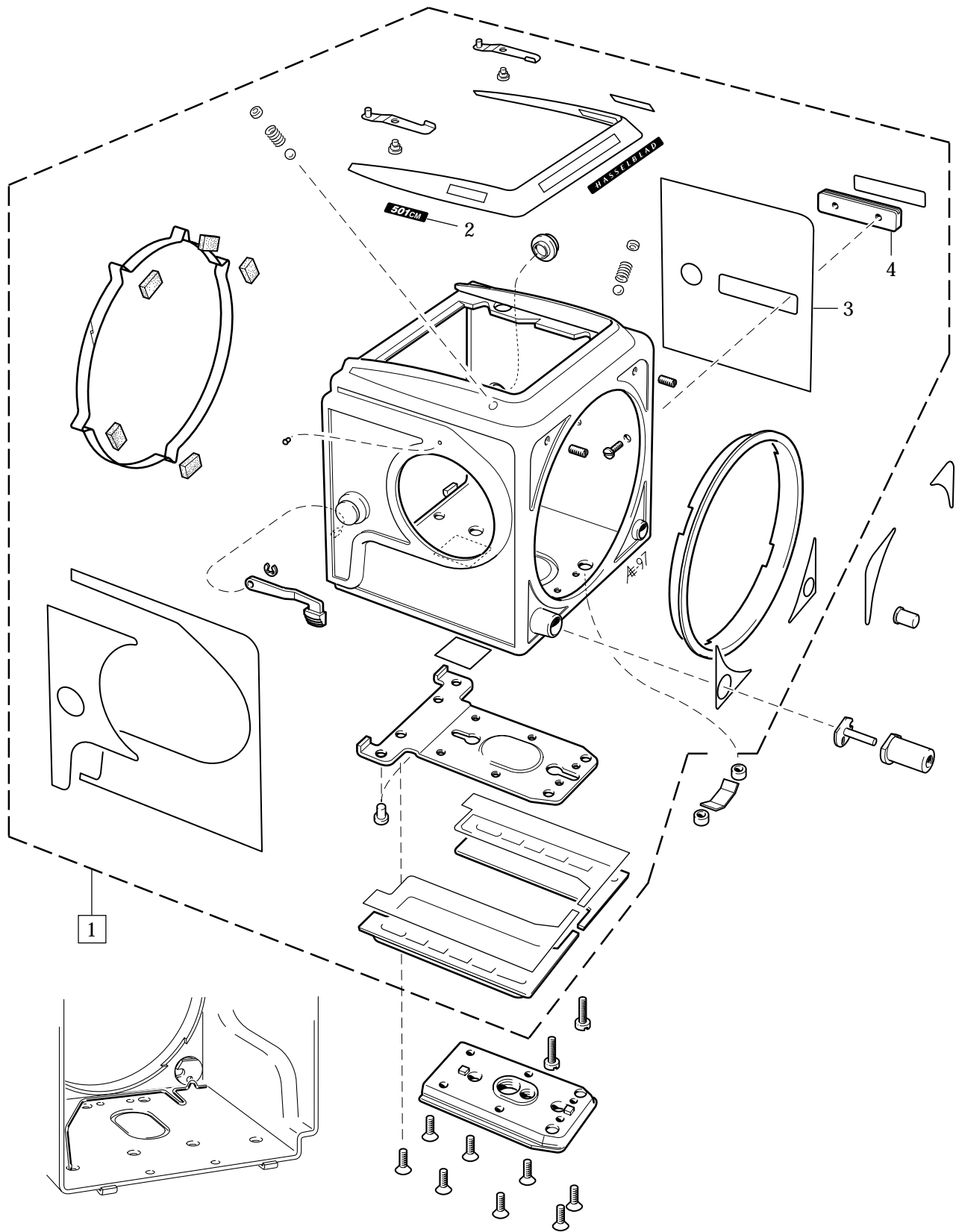



**H A S S E L B L A D**  
**Camera body 501CM**

**19:1**

<b>Pos No.</b>	<b>Pcs</b>	<b>Spare Part No.</b>	<b>Description</b>	<b>Remark</b>
1	1	40 407	Shell, complete (Chrome)	Part No. 40408 (black)
2	2	22 862	Name plate	
3	1	103 592	Leather	
4	1	103 529	Accessory rail	

**Spare parts not listed are the same as for 503CW**

Camera body 501CM

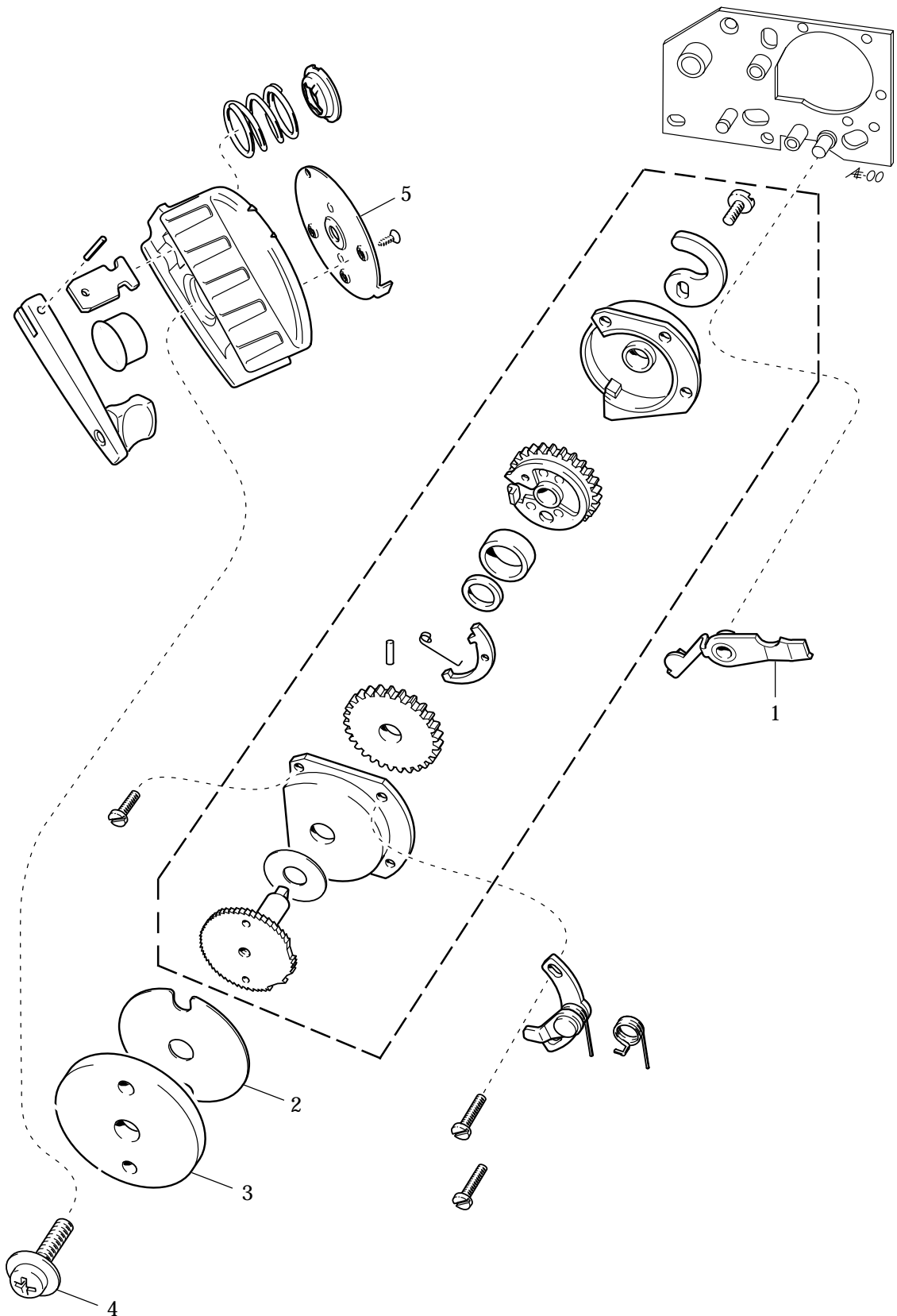

**H A S S E L B L A D**  
**Camera body 501CM**

**19:2**

<b>Pos No.</b>	<b>Pcs</b>	<b>Spare Part No.</b>	<b>Description</b>	<b>Remark</b>
1	1	13 355	Stop lever	Alternatively none or 1 pc
2	1	22 799	Washer	
3	1	412 401	Spacer	
4	1	830 061	Screw	
5	1	412 103	Coupling	

**Spare parts not listed are the same as for 503CW**

# Camera body 501CM

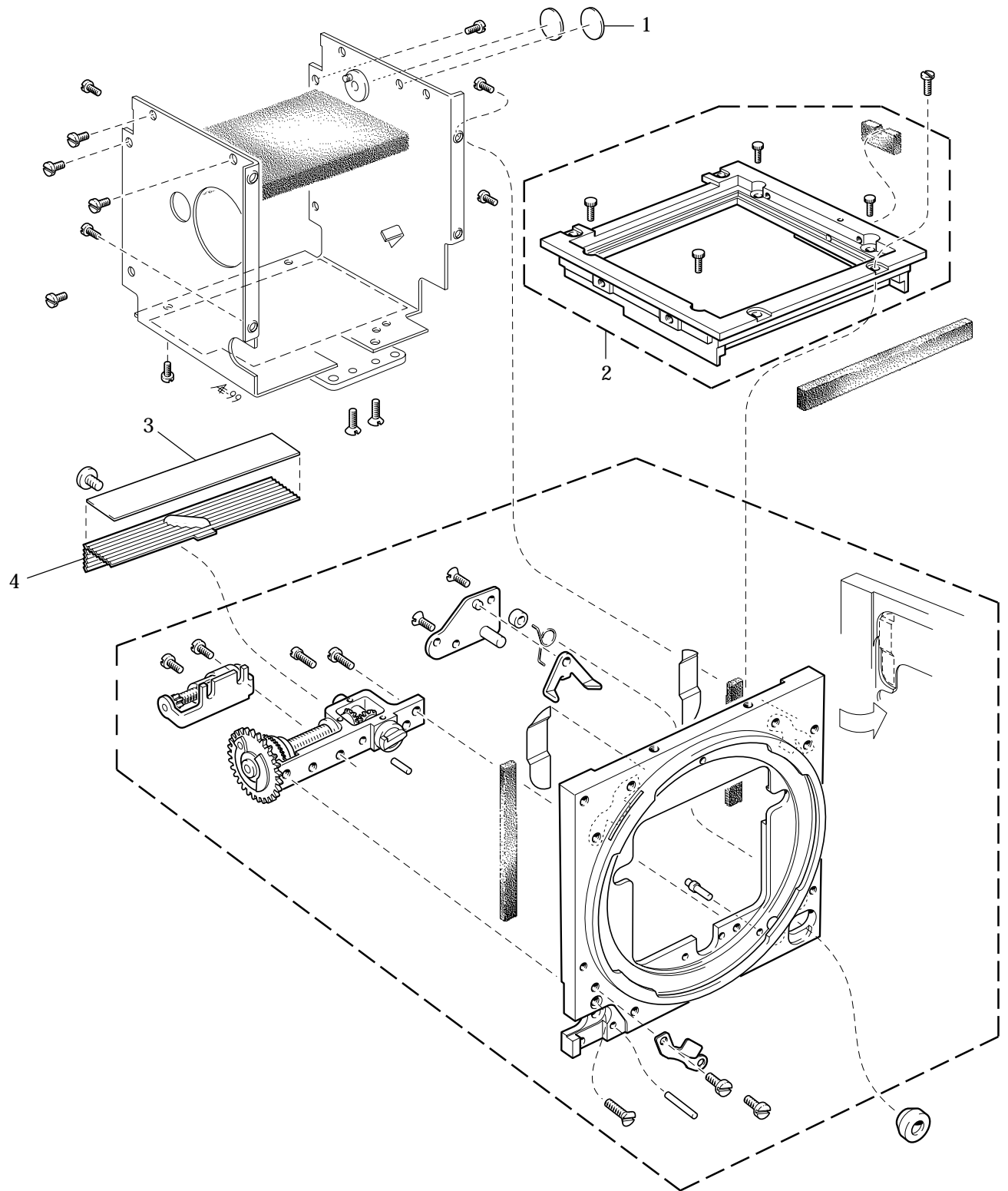

**H A S S E L B L A D**  
**Camera body 501CM**

**19:3**

<b>Pos No.</b>	<b>Pcs</b>	<b>Spare Part No.</b>	<b>Description</b>	<b>Remark</b>
1	2	22 865	Light shield	Incl. reflection protector 22 873
2	1	22 806	Frame, complete	
3	1	22 873	Reflection protector	
4	1	22 892	Cover	

**Spare parts not listed are the same as for 503CW**