

THE PRACTICAL ACCESSORIES

Rolleiflex
Rolleicord

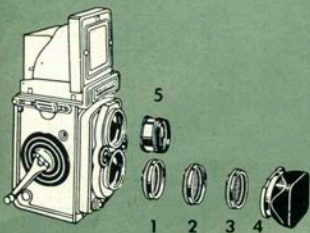

FRANKE & HEIDECKE · BRAUNSCHWEIG



When using several lens accessories:

Taking lens

1. Rolleinar
2. Rolleisoft
3. Filter or Rolleipol
4. Lens Hood

Viewing lens

5. Rolleinar with prism

If two or more supplementary lens accessories are to be used, they must be attached in this order. Rule: Rolleinar always first (lens to lens) and filters last.



Accessories with bayonet fitting,

supplied in three sizes.

- I For Tessar, Triotar and Xenar 3.5
- II For Planar and Xenotar 3.5
- III For Planar and Xenotar 2.8

Please note proper size when ordering! When ordering other accessories, supply the camera number, lens type and lens number.

LENS HOOD

Designed for: Protecting the lens against extraneous light and reflections outside the field of the picture. It thereby assures brilliance and purity of color in the photograph. Also protects against spotting the lens in snow, rain or water sports.

To attach: Place the sun shade on the outer bayonet of the taking lens so that the upper edge is horizontal.

ROLLEIGRID

(Not necessary when using Rolleikin)

Designed for: Brightening the corners of the ground glass image in unfavorable light.

To install: Place the Rolleigrid, small beveled edges upward, on the ground glass screen. Let it slide forward under the retainer tab, then drop the rear edge and fasten by means of the push-button at the rear of the focusing hood (see also p. 13, B 5). The condensing lens must be placed on the ground glass with the grooved side down.

To Remove: Turn the camera over, push the button, letting the Rolleigrid fall out of the hood.

To clean the Rolleigrid:

Use only a wad of cotton and a mild water and soap or detergent solution, squeezed almost dry.

EXTENSION HOOD

Designed for: Extending the focusing hood to normal viewing level; minimizes light reflection from top of ground glass; allowing observation of image without distraction.

To use: Slip over the opened focusing hood so that the upper rounded edge rests on the forehead and the inner folded "breath guard" rests on the bridge of the nose.

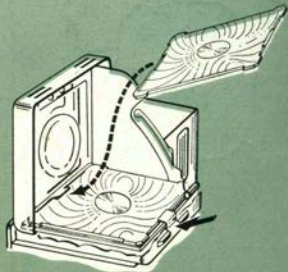

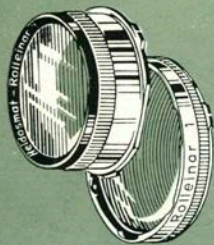

ROLLEINARS 1 and 2

Designed for: Close up shots at distances closer than 1 meter.

Use: With the two Rolleinar sets 1 and 2, the Rollei is converted for a focusing range from $39\frac{1}{2}$ — $17\frac{3}{4}$ ($18\frac{1}{2}$) in. and $19\frac{3}{4}$ — $12\frac{1}{8}$ ($12\frac{1}{2}$) in., see page 5. Each set is composed of two optically matched frontal lenses with different mounts. The Rolleinar with the thicker mount is

for the viewing lens (Heidosmat) and contains a built-in prism for parallax correction. As a result the field of view in the ground glass coincides with the photograph even at very short distances. A red dot on the mount indicates the uppermost side of the lens for correct positioning in use.

The same instructions apply to the Rolleinars with bayonet size I (see page 2), using a separate Rolleipar parallax corrector for each set. Here too the Rolleipar is always attached to the viewing lens Rolleinar red dot up.

Focusing is accomplished as usual on the ground glass screen. The depth of field being rather limited at close range, considerable stopping down is advisable with Rolleinar lenses. The depth of field table indicates the most advantageous stops for the $2\frac{1}{4} \times 2\frac{1}{4}$ - and $1 \times 1\frac{1}{2}$ -inch size.

The advantage of a large reproduction should not mislead to indiscriminate shortening of the camera-to-subject distance with close-ups, as this practice would entail danger of distortion. It is less great with objects having a shallow depth of field. For the same reason portrait heads should, if possible, not be taken at distances closer than 40 in.

Rolleinar Lenses require no increase of exposure.

To install: First attach the taking lens Rolleinar and then the viewing lens Rolleinar with prism in front. Insert into the inner bayonet and turn to the right until they click into position. The red dot on the viewing Rolleinar must be up!

Focal Length and Focusing-Range with Rolleinar Lenses

Rolleinar Lenses	—	1	2
Focal Length	75 (80)* mm.	71 (76)* mm.	68 (72)* mm.
Focusing-Range (in inches)	∞ — $35\frac{1}{2}$ (∞ — $39\frac{1}{2}$)*	$39\frac{1}{2}$ — $17\frac{3}{4}$ ($39\frac{1}{2}$ — $18\frac{1}{2}$)*	$19\frac{3}{4}$ — $12\frac{1}{8}$ ($19\frac{3}{4}$ — $12\frac{1}{2}$)*

Field-Size and Scale of Reproduction

Focused Distance		$31\frac{1}{2}$ in.	$19\frac{3}{4}$ in.	13 in.
Field-Size (in inches)	$2\frac{1}{4} \times 2\frac{1}{4}$	22 x 22	$13\frac{3}{4} \times 13\frac{3}{4}$	$8\frac{3}{4} \times 8\frac{3}{4}$
	Rolleikin	$9 \times 12\frac{1}{2}$	$5\frac{1}{2} \times 7\frac{7}{8}$	$3\frac{1}{2} \times 5\frac{1}{8}$
Scale of Reproduction approx.		1 : 10	1 : 6.3	1 : 3.9

Depth of Field with Rolleinar Lenses

Rolleinar	1		2		f/Stop	
	$31\frac{1}{2}$	$23\frac{1}{2}$	$19\frac{3}{4}$	$15\frac{3}{4}$		
Depth of Field (in inches)	$29\frac{1}{2}$ — $33\frac{1}{2}$	$22\frac{1}{2}$ — $24\frac{3}{4}$	$18\frac{7}{8}$ — $20\frac{1}{2}$		5.6	Rolleikin ↓
	$28\frac{3}{4}$ — $34\frac{1}{4}$	$22\frac{1}{4}$ — $25\frac{1}{4}$	$18\frac{3}{4}$ — $20\frac{7}{8}$	$15\frac{1}{8}$ — $16\frac{1}{2}$	8	
	28— $35\frac{3}{4}$	$21\frac{5}{8}$ —26	$18\frac{1}{8}$ — $21\frac{1}{4}$	15 $16\frac{7}{8}$	11	
	$26\frac{3}{4}$ — $38\frac{1}{4}$	$20\frac{7}{8}$ — $27\frac{1}{4}$	$17\frac{3}{4}$ —22	$14\frac{5}{8}$ — $17\frac{1}{4}$	16	$2\frac{1}{4} \times 2\frac{1}{4}$ ↓
	$25\frac{1}{4}$ — $41\frac{3}{4}$	20— $28\frac{3}{4}$	$16\frac{7}{8}$ — $23\frac{1}{4}$	$14\frac{1}{4}$ — $18\frac{1}{8}$	22	

Distances are measured from lens board to subject. The figures given in the tables are, for all practical purposes, usable with both 75 and 80 mm. lenses. Permissible circle of confusion = approx. $\frac{1}{1000}$ of the focal length of 75 and 80 mm. respectively.

* Figures given in parenthesis apply to a focal length of 80 mm.

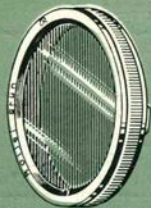

ROLLEI FILTERS

A. Filters for black and white photography

Designed for: Enhancing the contrast and separation of colors, correction of film sensitivity to the various colors and, at times, the elimination of certain undesirable portions of the spectrum.

Explanation: By elimination or modification of certain portions of the spectrum, the particular color of the filter is rendered brighter and its

complimentary color darker. Colors which show little or no difference in brilliance are thus rendered with a greater black and white contrast or tone separation. Thus with two colors, either can be rendered darker depending on the choice of the filter.

Use: (see page 8) Yellow and also green filters are especially useful for improved rendering of clouds. Orange and red for cutting through the bluish haze in the distance. Blue for improving the otherwise too pale flesh tones in studio portraits using panchromatic emulsions with high red sensitivity. Infrared for the exceptionally revealing qualities of the red and the invisible infrared rays. Ultraviolet protective filter for the absorption of the photographically harmful ultraviolet rays.

B. Color conversion filters

Designed for: Adjustment of the light composition (color temperature) to better match the color balance of color films (especially transparency films).

Explanation: Every color film is balanced to a definite color temperature depending on its intended use. At this color temperature, the film produces true to nature colors. With ascending temperatures, however, an over-all blue color cast appears, whereas with low color temperature, an over-all redish cast predominates. Color conversion filters serve to eliminate these undesirable color casts.

Use: The red-brown colored filters when blue predominates, and blue colored filters when red predominates in order to reestablish the balance of the light reaching the film. Each filter type is supplied in these three strengths, 2, 5 and 11, (abbreviated forms of 20, 50 and 110 Mired). Intermediate gradations can be formed by combining any two filters.

Modern color temperature meters will indicate the proper filter to use, taking into consideration the type of film and the prevailing light conditions. The most commonly encountered ranges of color temperature are also covered in the double table A + B (page 7 and 9).









Example: Ektachrome daylight film, overcast sky . . . which filter?

Solution: 1. **Film:** Look up film type (brand) being used. (Ektachrome - daylight = upper part of page), follow appropriate guide line to edge of page (5500° Kelvin), slide page 7 to the left until guide line A (5500° K) and B meet. Hold pages in this position!

2. **Lighting:** Observe the type of lighting and its color temperature range (overcast = 6600°—7000°).

3. **Filter:** The adjacent gray bar of table B indicates the filter (R 2) with light value correction (—0.5) and the extension of exposure, 1.5 times.

The guide lines hereunder listed require sliding page 7 somewhat further to the left.

		Lighting		°Kelvin				
Daylight	Film Type	5500	 Clear blue sky: in shadow	24000				
				Deep shade, clouds	19000			
				Overcast	16000			
				Cloudless, sun to the side	14000			
				Electronic flash	12000			
				3800		Blue flash bulbs	10000	
						Sun 9:00 A.M.-3:00 P.M.	9000	
							Sun before 9:00 A.M., after 3:00 P.M.	8200
								7600
								7000
Artificial light	3200		Clear, wire-filled flash bulbs	6600				
				Photo flood lights	6200			
				SM and SF flash bulbs	5800			
					5500			
					5200			
					5000			
					4700			
		4500						
		4350						
		4150						
		4000						
		3800						
		3700						
		3550						
		3400						
		3300						
		3200						
		3100						
		3000						
		2900						
		2850						

Rollei filters for black and white photography

Light value correction = exposure increase factor. General average values are given for pan emulsions (in parenthesis for ortho emulsions). These, however, can be modified according to the type and brand of the photographic material and according to the type of lighting.

Rollei Filter	Light value adjustment	Exposure increase	Application and effect
Light yellow	-1 (-1.5)	2x (3x)	Landscapes, snow, clouds. Renders yellow and green lighter, blue darker.
Medium yellow	-1.5 (-2)	3x (4x)	
Light green	-1 (-1.5)	2x (3x)	Landscapes, snow, clouds. Renders green lighter, red (complexion) and blue darker. For pan emulsions.
Green	-1.5 (-2)	3x (4x)	
Orange	-1.5 to -3	3-7x	Hazy distant views. Renders yellow-red lighter, blue darker, distant objects clearer.
Light red	-2 to -3.5	4-10x	Hazy distant views. Renders red lighter, blue-green darker. Gives stronger effects than orange filter.
Light blue	-0.5 (-0.5)	1.5x (1.5x)	Artificial light. Renders red darker. For ultra-pan emulsions.
UV	-0.5 (-0.5)	1.5x (1.5x)	High altitudes above 6000 feet. Seascapes. Eliminates ultra-violet rays which reduce contrast.
Infrared *	Exposure depends on the type of emulsion used and must be determined by tests.		Special filter for infrared emulsions. Transmits dark red above 700 m μ and infrared.

* The infrared filter features special compensation for focusing difference between visible and infrared portion of the spectrum. Direct ground glass focusing may be employed with full assurance of sharp pictures.

Rollei filters provide maximum effectiveness

By using coating-adjusted filters with the lenses, the brilliance of the picture is essentially heightened. This heightening of contrast is fully effected only when proper lens accessories are used.

Rollei optical lens accessories are supplied with anti-reflection coating which will not wear off. The Rollei filters, in particular, have an individual type of coating designed to enhance the effect of their particular color. They achieve maximum contrast in their specific range of operation.

The illustrations indicate filter density and filter combination. Light value corrections and increase of exposure factors have been rounded off to nearest half values. If the table permits a choice amongst several filters, then in case of doubt the weaker filter is to be preferred.

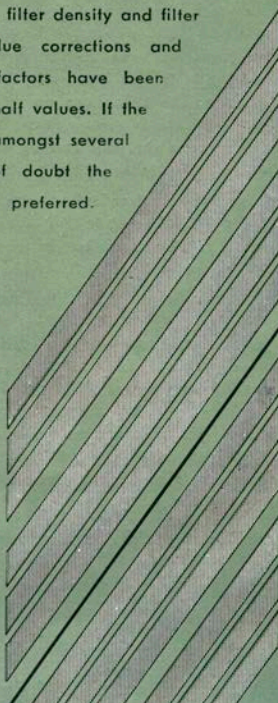

Filter

B

R 16		-1,5	3 x
R 13		-1,5	3 x
R 11		-1	2 x
R 7		-1	2 x
R 5		-0,5	1,5 x
R 2		-0,5	1,5 x
B 2		-0,5	1,5 x
B 5		-1	2 x
B 7		-1,5	3 x
B 11		-1,5	3 x
B 13		-2	4 x
B 16		-2,5	6 x



ROLLEIPOL

For black and white and for color.

Purpose: Elimination or subduing of disturbing reflections (glare) from shiny, non-metallic objects or surfaces. Under certain conditions, filtering of the blue sky. Especially useful for regulation of the colors (colored reflections) and control of sky tone in color pictures.

Explanation: If the direction of movement of a light beam is imagined to be the axle of a wheel, then the spokes of the wheel correspond to the various plans of oscillation of the light

waves; (i. e., we are looking at the light beam in cross-section). Polarization will reduce the many planes of oscillation to merely one.

Polarization takes place when light waves, striking at a certain angle, are reflected by shiny bodies (with the exception of metals). This polarized segment of light can be retained in full or in part by placing the RolleiPol filter across the plane of oscillation: the reflections disappear. (The filter itself has a polarizing effect on the light which passes through it.) Further, since there is also polarized light in the blue sky, this can be eliminated: the use of the RolleiPol filter results in subdued (darkened) sky portions.

Not all reflected light is polarized. If reflections are to be eliminated, 1. the filter must be turned (on its optical axis) in the direction of the vibrations as required, and 2. the camera position must be changed to gain the best effect. This is attained when the beam of light striking the reflecting body and the line of camera view form an angle of 60—74°, (varies according to material of the subject).

Application: 1. For eliminating or subduing disturbing reflections when photographing reflecting objects (polish, porcelain, painted and lacquered finishes, etc., — reproduction of textures and material), when photographing glass surfaces and the surface of water (the reflecting surfaces become transparent), 2. for filtering sky when photographing landscapes: the blue sky is darkened by absorption of the polarized light it contains. The effect may be observed in advance by looking through the filter. Light value correction about $-1.5 =$ increase of exposure about $3\times$.

For Use: Fasten the RolleiPol filter on finder lens (red dot on the top) and rotate the front ring of the RolleiPol until the desired effect is obtained on ground glass. Note the white number marking and transfer to the taking lens in the same position.

ROLLEISOFT LENS 0 and 1

Purpose: Softening of super-critical definition producing striking fluffy halo-effects, especially with back-lighting.

Explanation: The taking lens of the Rollei gives super-critical definition required for the majority of exposures. If, occasionally, softer definition is desired (e. g. for portraits and certain dramatic effects) this is obtained by attaching the Rolleisoft Soft Focus Lens in front of the lens.



The Rolleisoft lens consists of a plane parallel glass disc with a few concentric ground-in grooves. While otherwise the lens permits only sharpness or softness through adjustment of the focus, the Rolleisoft lens obtains both simultaneously: Between these grooves the rays of light pass unimpeded to the film and produce a sharp impression, i. e., the basis of the image. At the grooves, however, the light rays are diverted with the result that an additional image of slightly softer definition is superimposed. Both together produce the soft focus effect: The exposure shows fluffy softened contours and sunny halo-lights; distracting fine details recede and the total impression of depth definition is improved. By means of the Rolleisoft the Rollei-lens becomes a soft focus lens.

Application: Best results are obtained by using the entire surface of Rolleisoft, i. e., with full aperture. With Rolleisoft 1 (with increased number of grooves) it is permissible to stop down to $f:5.6$. Smaller apertures tend to decrease the soft focus effect.

Rolleisoft 0 is used for weak soft focus effect: primarily for strong contrasts of light and glittering objects, i. e., chiefly for backlighted subjects. Rolleisoft 1 is used for greater soft focus effect: for soft lighting. — Chief field of application generally: portraiture. Best suited for: contrasting, highlighted subjects. Rolleisoft increases the plastic, sunny character of backlighted pictures. Speed and focal length remain unchanged. Generous exposures increase the halo-effect. The ground glass screen shows full focused sharpness when using Rolleisoft lenses. The Rolleisoft effect can be judged at any time on the ground glass screen by placing the Rolleisoft in front of the finder lens.

For Use: Fasten Rolleisoft to inner bayonet of the taking lens.



1

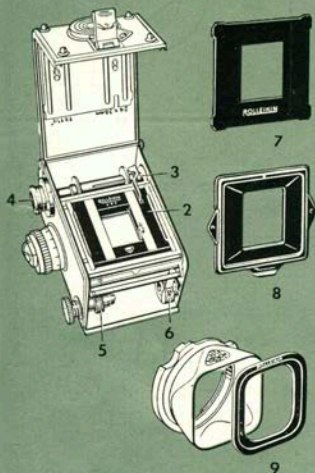

7

8

9

A

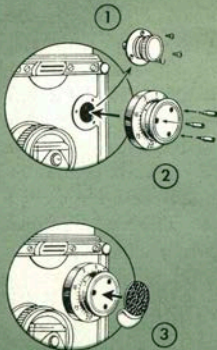

1

2

3

ROLLEIKIN 3.5 and 2.8

Designed for: Taking up to 36 exposures $1 \times 1\frac{1}{2}$ in. on 35-mm.-film. Ideal for series of pictures and color photography on miniature film.

The attachment consists of:

1. Case
2. Film Guide Frame
3. Take-up Spool
4. Exposure-Counter-Knob*
5. Extension-Spindle for Rewind-Knob (two types, for previous and new Rollei models)
6. Inner Spool Knob
7. Focusing Screen Mask
8. Direct View Finder Mask
9. Lens Hood Mask.

Applicability of this accessory: Fits Rollei-flex above numbers 1100 000 and Rollei-cord above numbers 1137 000. (The combination back for two picture sizes was originally not provided with the first camera series, but can be ordered additionally). — Earlier Rollei-models use Rolleikin 1 (with special back).

A. Installing the Counter-Knob*

(The exposure-counter-knob accepts 35 mm. and No. 120-[B 2-] film. Your dealer will gladly take care of the fitting for you.)

1. Remove the top film-knob by unscrewing the 3 counter-sunk screws.
2. Fasten counter-knob tightly by means of the three screws supplied.
3. Remove protective lining from gummed insert and paste it on the counter-knob.

* Not required with Rolleikin 2.8.

B. Assembling the Rolleikin

1. Adjust film pressure plate by a sliding movement, pressing down at the same time, thereby bringing the inscription "24 × 36 mm. (1 × 1½ in.)" into view.
2. Pull counter-knob, fit-in take-up spool on the right and insert completely.
3. Rewind-Parts: Screw extension-spindle on rewind-knob by rotating the latter. Snap inner spool-knob over opposite spool bearing pin, (slipping the metal tongue between the rollers of the film-feed when using a Rolleiflex).
4. Inserting the film guide frame: Press spring actuated clamp-bar at an acute angle (as shown) against the bottom of the film gate and insert completely. To remove: Push frame downward (against the clamp-bar) and lift out.
5. First insert forward edge of focusing screen mask under the grip, snap down and secure by pressing the retaining device. Be sure the mask is properly centered inside the ground glass frame.

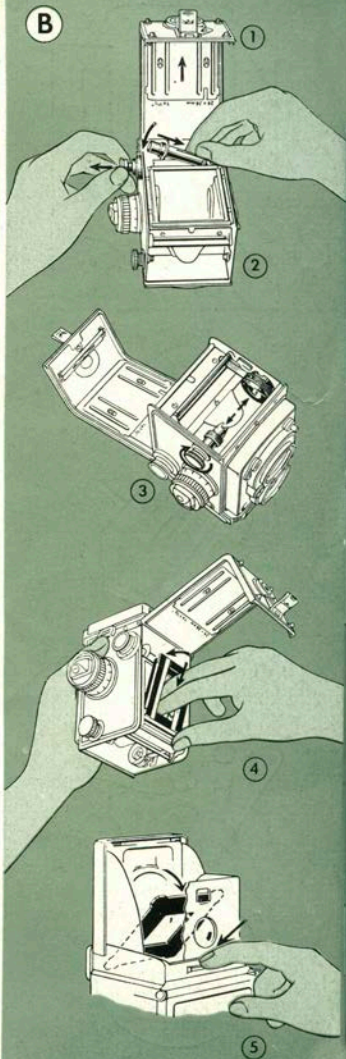

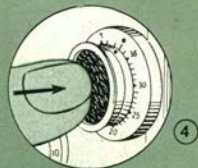
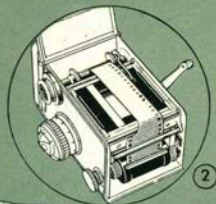
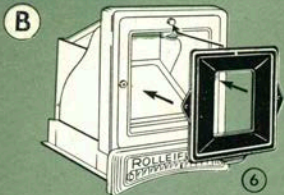

6. Insert the frame-finder mask underneath the button above the frame-finder in such a way that the edge (marked with a white dot) is pushed-in first, then press the two lateral fixing buttons into position.

C. Loading

1. Open camera back, pull rewind-knob, fit-in film cartridge on the left and then insert fully.
2. Introduce film-lead (which — in the Rolleiflex — first passes through the film-feed rollers) into the double slit of the take-up spool, letting it touch on the right. Tighten up by giving spool a short turn.
3. Make sure the mouth of the cartridge points straight ahead in line with the tightened film lead, then close back.
4. Press-and-release counter-knob until the red dots of the Rolleikin counter face each other. (Disregard counter for No. 120-[B 2-] film completely.)
5. To set counter for the first exposure: Advance counter dial to No. 1 by actuating filmtransport three times (see page 15).

D. Filmtransport

1. Press-and-release counter-knob before actuating filmtransport. The exposure counter advances automatically to the next number.
2. Advance film as usual to the stop.

E. Rewinding

1. After the last exposure has been made, rewind film by keeping counter-knob pressed down,
2. simultaneously rotating rewind-knob clockwise.

F. Note

1. The rewind also permits the removal of only partially exposed films. In order to prevent the film lead from slipping into the cartridge when rewinding, be sure to thread the film backward, i. e., against the winding direction into the double-slit of the take-up spool when loading.

When reloading a partially exposed cartridge, advance film two frames beyond the last exposure (skipping one frame for safety).

2. Always adjust film pressure plate properly (see B 1). (A sure sign of incorrect adjustment when using the Rolleikin: Camera back will not close all the way.)
3. When installing the Rolleikin in the camera the empty roll film spool should be laid safely away in the Rolleikin case for later use since it must be used again when inserting the next roll of film.
4. Shutter cocking as usual: with Rolleiflex, normal swing of the crank.
5. Double exposure device is in operation in the Rolleiflex and cannot be disengaged when using Rolleikin. With Rolleicord it must be disengaged in order to unlock shutter.

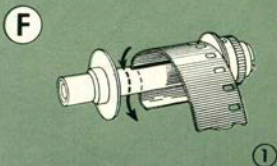
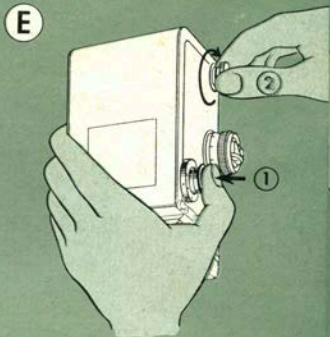
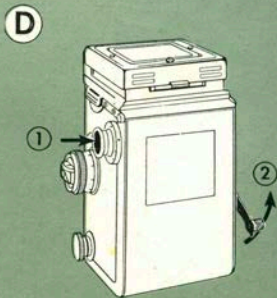

PLATE-ADAPTER

Designed for: Single $2\frac{1}{4} \times 2\frac{1}{4}$ inch-exposures on $2\frac{1}{2} \times 3\frac{1}{2}$ inch-plates of sheet-film. A desirable facility for the use of special emulsions, immediate or individual processing and such special tasks as studies of portraiture, trick-photography, reproductions, technical tests etc.

The outfit consists of:

- 1 Adapter back (1)
- 3 Cut-film or plate holders (2)
- 3 Cut-film sheaths (3)

Also available:

- Focusing-screen slides (3)
- Leather case for two holders

All parts are available separately. Focusing is done as usual on the reflex focusing-screen and only in special cases (f. e. when using two Rolleinars combined, or utilizing the picture area to the fullest extent) on the adapter focusing-screen.

A. Attaching the Adapter Back

1. Remove take-up spool from camera.
2. Take off camera back.
3. Attach adapter back (without plate holder!).

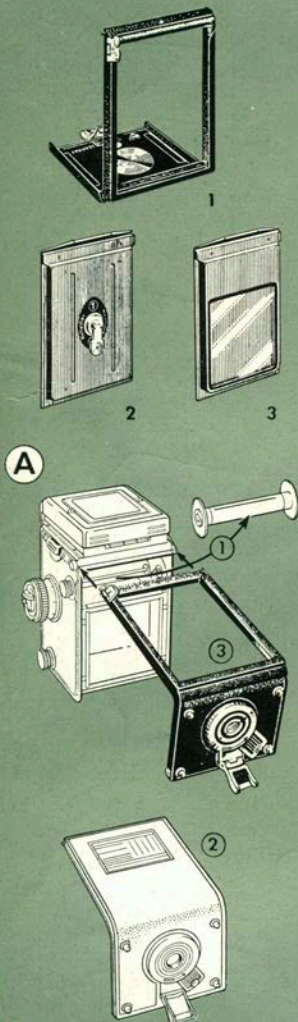

B. Loading the Plate-Holder

1. Withdraw slide.
2. Lift up locking lever on back of holder and
3. let it slip inside after a quarter-turn. Spring action pushes out plate-carrier.
4. Slide plate (or cut-film with cut-film sheath placed underneath) into carrier.
5. Retract lever, lock by a quarter-turn and fold down (the number remaining visible). Close holder by reinserting slide.

Note: Conserve plush-strip by always removing slide from empty holders before storing away.

C. Inserting the Plate-Holder

Swing catch out of way and slide holder down the lateral grooves of the adapter back. The catch locks holder against unintentional removal.

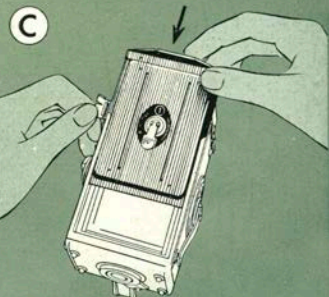
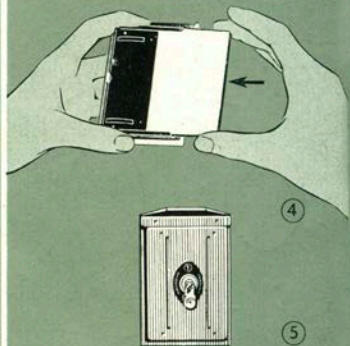
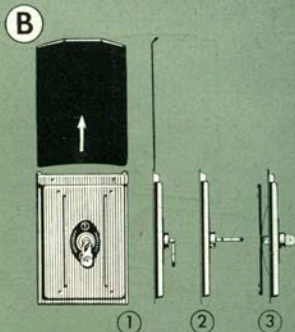

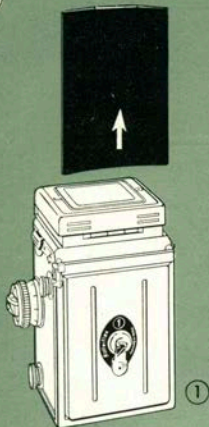
D

2

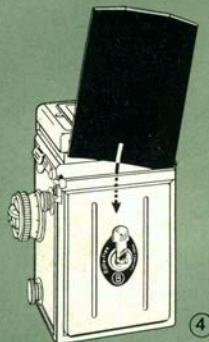

3

**D. Exposure**

1. Withdraw slide.
2. Lift up lever and let it slip inside after a quarter-turn. The plate moves into the focal plane by spring action.
3. After the exposure, retract lever first, then fold upward after a quarter-turn. The letter "B" indicates that the plate has been exposed.
4. Only now reinsert slide.

E. Focusing-Screen Holder

1. Insert the closed holder.
2. Withdraw slide. Spring action presses focusing screen automatically into the focal plane.
3. Reinsert slide first, and then remove holder.

F. Note

1. Shutter cocking as usual: with Rolleiflex, normal swing of the crank.
2. For use of plate adapter with Rolleicord the double exposure device must be disengaged in order to unlock shutter.

PANORAMA HEAD

Purpose: Panorama pictures, composed of two or more individual pictures. Complete circle (360°) may be had with 10 exposures.

For Use:

1. Screw panorama head at first only lightly into tripod socket.
2. Match pins and sockets of panorama head and camera, then press together.
3. Tighten screw firmly.
4. Mount on a sturdy tripod.
5. Level off horizontally by centering bubble of spirit level.
6. Start exposures at left of proposed view — swing camera one number or click to right for each succeeding exposure.
7. Care should be used when trimming pictures for mounting — sufficient overlap is provided to make matching easy. If moving clouds are included in pictures, exposures must be taken in rapid succession.
8. Make full use of entire negative area and be sure that prints match in contrast and tone. Line the pictures up accurately and cut them. Mount on cardboard with matching edges together and panorama is ready.

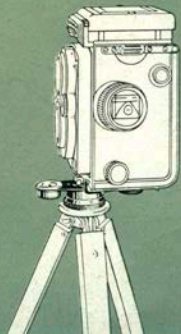

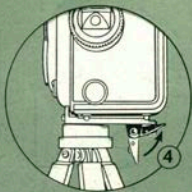
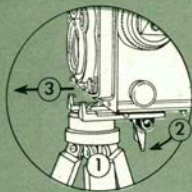

A

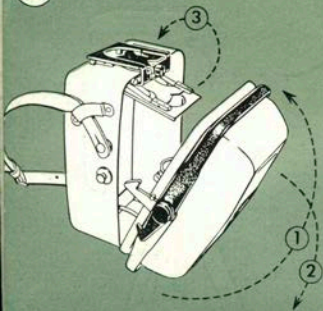

ROLLEIFIX TRIPOD HEAD

Can be used for all Rollei models with grooved edge on the tripod socket.

Designed for: Quick fastening of the Rollei to the tripod or to the bracket of an electronic flash unit.

Operation:

1. Screw the Rolleifix firmly to the tripod.
2. Raise the catch on the under side of the lock-lever and push lever downward.
3. Place the camera on the Rolleifix and slide it forward so that the tripod socket reaches the forward end of the retaining grooves.
4. Throw the locking lever upward to secure.

METAL EVER READY CASE

For use with all Rollei models provided with groove on the edge of the tripod socket.

Designed for: Complete protection: Air, dust, water-tight. For storing the camera in a floatable splash-proof, light metal container; unique pivoting bracket provided for fast shooting.

A. To open:

1. With a circular movement raise the clamp handle.
2. Push the front part of case down.
3. Push the camera case back and press down firmly until it is fully opened.

4. Swing the camera up and back in the retaining grooves of the tripod socket until the catch locks.
5. In order to change film: Press the locking lever on the front of the holder downward and pull the camera forward out of the holder.

When taking pictures the case may either remain open (for photography at eye level the two sides serve as handles) or can be almost closed.

B. To close:

1. Grip with two fingers behind the pivot of the camera holder, unlock it by pulling forward and move the camera forward and downward.
2. Raise the lower part, close the case and pull the clamp handle around and down until it locks. Make certain that the two catches close properly.

C. Notice:

1. In order to use the Rolleicord in the case, an extra (provided) rubber pad is glued on the corresponding pad in the case.
2. In the two spring steel clips of the case, 1—2 extra rolls of film or Rollei desiccant tubes (for absorption of the moisture within the case), can be placed. The discoloration of the deep blue silicon crystals indicates the extent of saturation. Repeated regeneration is possible by heating the tube (for example over a hot plate).

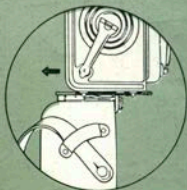

4

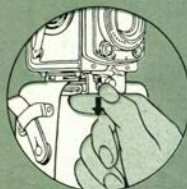

5

B

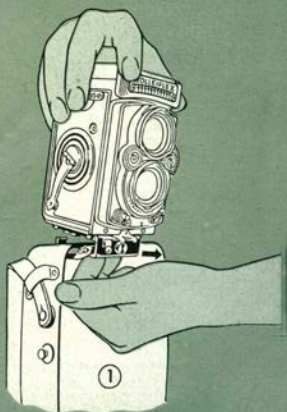

ROLLEIMETER for Rolleiflex

Purpose: An optical coupled range finder for use with the direct view finder of the Rolleiflex; particularly suitable when shooting sports or flash pictures in poor light.

Description: The Rolleimeter uses the superimposed image principle and is actuated by and coupled to the moving front panel of the camera. It is attached to the nameplate directly in front of the direct view finder. A vertical glass rod with focusing spot for the two images can be seen when looking through the finder. Focusing the camera by superimposing the two images so that the outlines exactly coincide insures sharp focus. Framing and focusing are accomplished while looking through the finder, without moving the eye from one position to another.

Before using the Rolleimeter two simple adjustments are required:

1. A one time adjustment of the actuating lever (screw **a**) to suit the focal length of the lens employed.
2. Adjustment of the lever button (screw **b**) so that the range finder indicates sharp focus at infinity (∞) when the camera is in focus at the same distance. This adjustment should be rechecked from time to time.

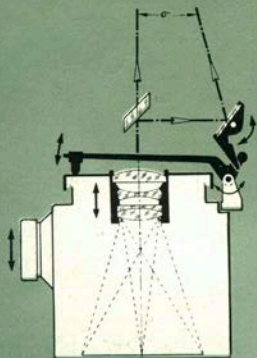
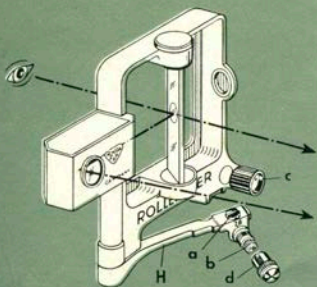
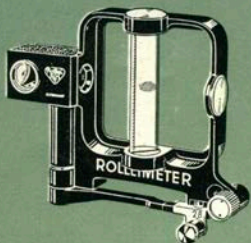

A. Adjustment to focal length

(This is done before attachment to the camera and is required so that the Rolleimeter and camera will agree even at close distances, such as three to five feet. See note 2.)

For this adjustment a special plate is provided, suitable for cameras calibrated in either feet or meters. For the focusing knob with exposure meter, a second "adjusting" plate of greater diameter is included. By its use the relationship between infinity and the close distance readings of the focusing knob scale may be observed and the Rolleimeter's actuating arm properly adjusted.

1. Place the adjustment plate over the focusing knob and line up the infinity marks, note whether meters or feet.
2. Note the figure on the adjustment plate which is directly opposite the marker for the closest focusing distance of the knob. Rolleiflex will have 3 feet as this distance.
3. Swing actuating lever **H** outward and loosen the coin-slotted screw **a**.
4. Move the slide to the previously observed adjustment plate figure and tighten screw **a**.

A

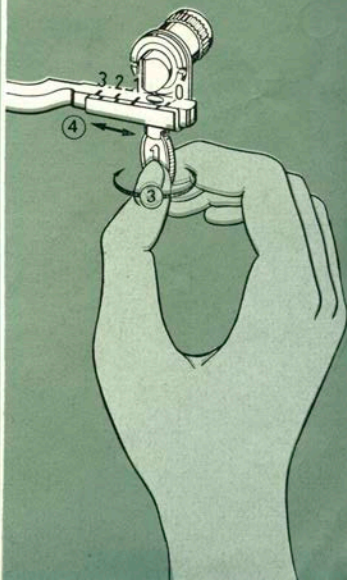
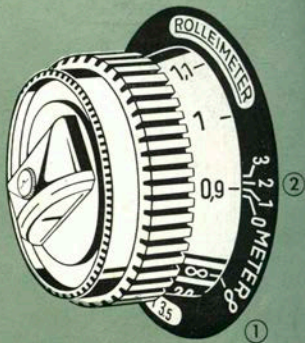

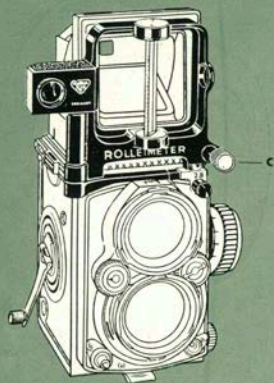
B

B. Attaching Rolleimeter to Camera

1. Set camera at infinity (∞).
2. Turn mounting screw **c** counter-clockwise until it stops.
3. Hook the Rolleimeter over the left edge of the nameplate and push it back so that the right side fastener can be engaged. Be sure that the actuating lever rests on the camera's movable front panel.
4. Hold Rolleimeter firmly in position with thumb and turn screw **c** clockwise until tight. Removal is effected by complete counter-clockwise turning of mounting screw **c** and lifting off.

C

②

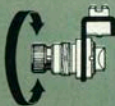

③



④

C. Adjustment to Infinity

(This is done after mounting Rolleimeter)

1. Set focusing knob to infinity (∞), open focusing hood and direct view finder.
2. Unscrew protective cap **d** and remove.
3. Select and observe some object (building, tree, lamp post, etc.) at least 600 feet distant. Looking at the focusing spot in the glass rod, turn screw **b** until the outlines of the two images coincide and the images become one.
4. Replace protective cap **d**, tighten, and double-check the coincidence of the two images. This adjustment should occasionally be rechecked.

D. To Use

Locate the object on the focusing spot of the Rolleimeter's glass rod, as seen through the open direct view finder, and turn the camera's focusing knob until images coincide. The Rolleiflex will be sharply focused to the exact distance of the object selected.

E. Note

1. For use with Rolleiflex 2.8 (80 mm. lens) the Rolleimeter 2.8 is supplied together with suitable adjustment plate.

2. Proper adjustment to focal length can be effected easily in the case of earlier Rolleiflex Cameras (whose knobs are not the right size to permit use of the adjustment plate) by means of the ground glass screen image. Following is the proper method:

First, make the infinity (∞) adjustment. Then focus the camera accurately on a suitable vertical object at the closest distance. Check the Rolleimeter and if the two images do not coincide, remove it and loosen screw **a**. Relocate the slide at some point in the adjustment range, between 0 and 3, where the images do coincide. Tighten screw **a**. Check the setting again and finally double-check the infinity adjustment. Correct if necessary (see A).

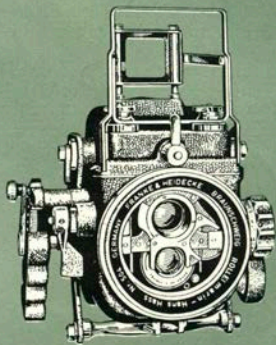

ROLLEIMARIN

Underwater housing for Rolleiflex f:3.5. Waterproof even at depths of more than 330 feet. Ground glass viewing and focusing through prism, with magnifier, in normal swimming position. All controls may be adjusted under water. Built-in rotating filter turret for two filters. Total weight: under water 3 lbs., above water 12 lbs. — Special accessories: carrying case, three filters (light and medium yellow, orange) in leather case, special flash unit (for both type lamp bases) in sail cloth bags.

Full information on the use in the booklet "ROLLEIMARIN".

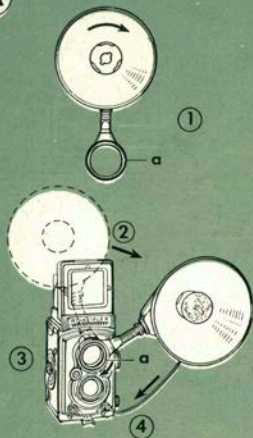
A

ROLLEIFLASH

Purpose: Synchronized flash exposures with the Rolleiflex.

Applicable: Flashbulbs with bayonet base (swan).

B-C principle (Battery-capacitor firing).

A. Mounting Rolleiflash

1. Fasten reflector on case by turning it clockwise in bayonet.
2. Fasten holding arm to bayonet of the viewing lens and
3. Secure by turning lock ring **a** clockwise. — Before removing: first loosen lock ring by turning counter-clockwise.
4. Pull out the cable and plug it into the flash socket on the camera. — To roll up the cord: use turn-knob (on cover of case).

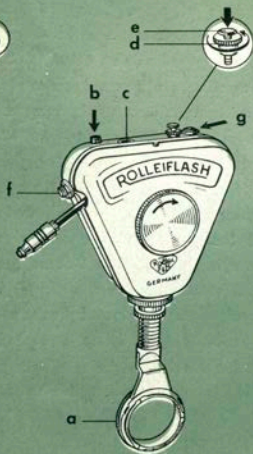
B

B. Exposure

1. Insert flash lamp as far as necessary to seat in the bayonet socket.
2. Test circuit (before connecting Rolleiflash comb.): Press test key **b** — brief flash of the test lamp **c** indicates positive firing of flash lamp.
3. Synchronized flash-firing: by releasing camera shutter (see directions for using camera).

Open-flash method (Firing by hand contact in making time exposures): loosen safety screw ring **d**, press hand contact **e**. Always secure hand contact when not in use!

The connector **f** is for use with the supplementary flash unit Rolleifläsh comb.

4. Lamp ejection: by pressing ejector button **g** — the lamp is forcefully ejected.

C. Changing Batteries

1. Loosen screw ring **h** slightly, open case upwards and remove. — To close the case: First attach cover with retaining pin on case, close tight, tighten screw ring **h**.
2. Changing the battery: **Important!** The + pole must always point toward the test lamp! Wrong insertion of battery would damage the condenser. Insertion of fresh battery (flat cell hearing aid battery 22.5 v.): press back contact spring **i** with the battery, snap battery in.
3. Changing test bulb: As replacement for defective lamps press same-type 6 v. glow lamp (0.05—0.07 ampères) between contact springs.

D. Flexible Arm

The flexible holding arm can be unscrewed from the case when the Rolleifläsh attachment is to be fastened directly onto a tripod by the base thread. To replace holding arm: turn back screw ring **k** on holding arm as far as it will go, screw arm into case (up to correct position of bayonet ring) and secure by turning screw ring **k** clockwise.

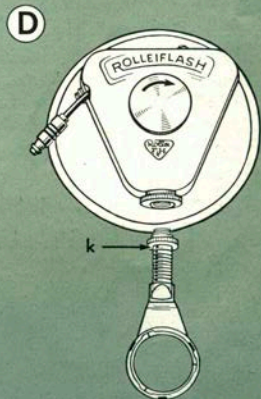
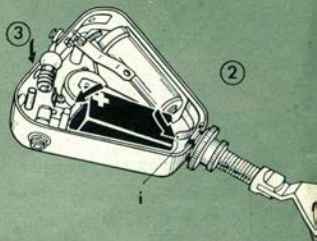
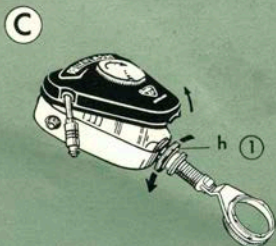

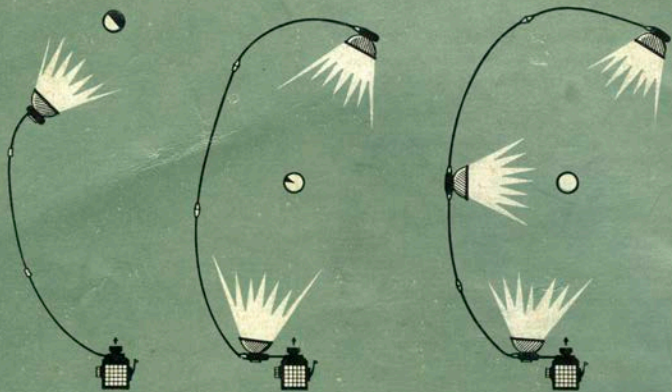

After attaching the cable: Put flash bulbs in Rolleiflash first and then in Rolleiflash comb.

In order to conserve the battery: Insert the flash bulbs a short time before shooting. Detach the cable to Rolleiflash when not using.

E. Rolleiflash comb.

Screw the cable end connectors to the Rolleiflash and Rolleiflash comb. The Rolleiflash comb. can either be hand-held or fastened to a tripod by the socket provided. The second connector is for an additional Rolleiflash comb., if used. A total of three lamps may thus be fired simultaneously. Lamp distance can be extended to 33 feet by means of 10 feet extension cords of two types, for Rolleiflash and Rolleiflash comb.

F. To attach Rolleiflash Extension Cords

Unscrew protective cap to limit, insert flash cord plug and tighten cap down over plug.