

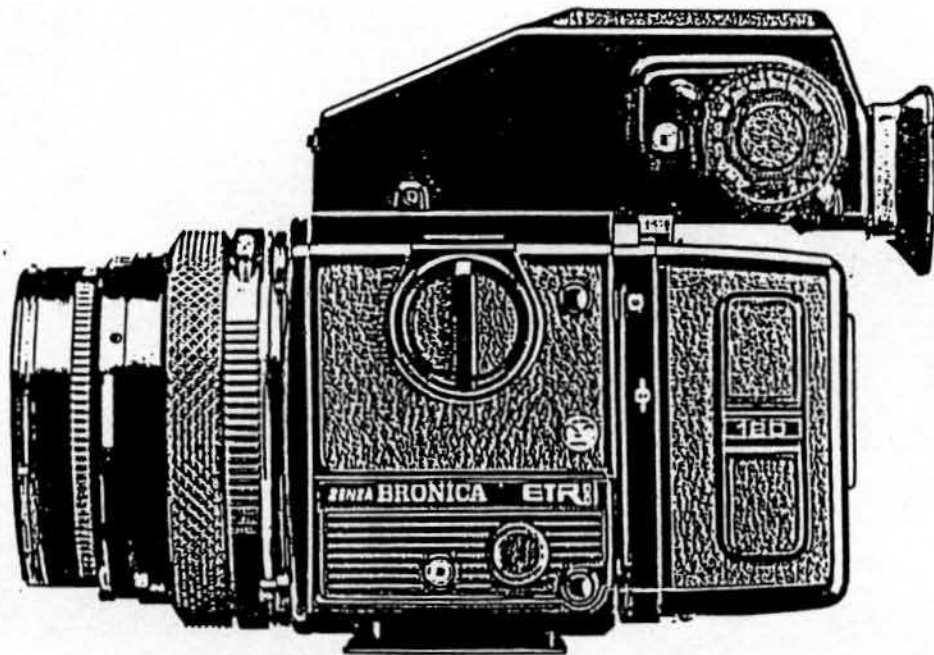

REPAIR MANUAL



ZENZA **BRONICA**

(MARCH 1990)

Concerning Repairs

1. It is recommended that correctly operating samples of the following components should be kept available for reference when making camera repairs and inspections.

Body	Back	Lens	AE finder
------	------	------	-----------

Defective components can be detected and checks can be made after repairs by replacing the various camera components with these correctly operating reference components.

For example, when a customer claims that the shutter is defective, a decision can be made as to whether the defective component is the lens shutter or the body shutter by merely replacing the lens and checking.

2. Never use organic solvents such as the shutter speed index lenses or exposure counter lenses with alcohol can result in cracking at a later date.
Use only alcohol to clean the focusing screen.
3. After completing a repair, always coat the lens mount very lightly with grease to make lens mounting smoother and prevent stick.

Part Numbers

All Bronica parts are assigned an 8-digit part number.

The last digit in the 8-digit part number ranges from 0 to 8 and indicates the sequence of part changes. (excluding such parts as screws, washers and E-rings).

Information concerning last digit changes will be provided as necessary.



The part numbers used exclusively for the ETRSi are as follows:

Individual body parts	0301[][][]0-
Body part assemblies	0319[][][]0-
Individual 120 film back parts	0302[][][]0-
120 film back part assemblies	0392[][][]0-
Individual 220 film back parts	0303[][][]0-
220 film back part assemblies	0393[][][]0-

--- Concerning camera repair and inspection

<u>Right cover removal</u>	-----	P- 1
<u>Winding unit removal</u>	-----	P- 3
<u>S. latch set removal</u>	-----	P- 5
<u>Shutter release button removal</u>	-----	P- 6
<u>F. release unit removal</u>	-----	P- 7
<u>Set lever removal</u>	-----	P- 8
<u>Mirror operating lever removal</u>	-----	P- 9
- Related operations -	-----	P-12
<u>Mirror frame and light tight frame removal</u>	---	P-13
<u>Left cover removal</u>	-----	P-15
<u>Circuit board names and wiring diagram 1</u>	----	P-16
<u>Upper frame/AE. connector removal</u>	-----	P-17
<u>Lens connector removal</u>	-----	P-18
<u>Shutter circuit unit removal</u>	-----	P-19
<u>Tripod shoe removal</u>	-----	P-22
<u>Film backs exchange function removal</u>	-----	P-23
<u>Shutter release function removal</u>	-----	P-24
<u>Battery box removal</u>	-----	P-25
<u>Brake mechanism removal</u>	-----	P-26
<u>Operating ring removal</u>	-----	P-27
<u>Front cover removal</u>	-----	P-28

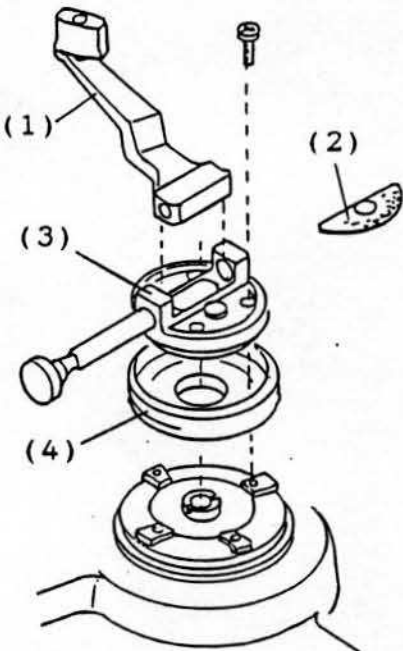
<u>Lens mount removal</u>	-----	P-29
<u>Mirror 45° adjustment</u>	-----	P-30
<u>Focusing adjustment</u>	-----	P-31
Circuit board names and wiring diagram 2	----	P-32
<u>Sensor adjustment</u>	-----	P-33
<u>Troubleshooting chart</u>	-----	P-37

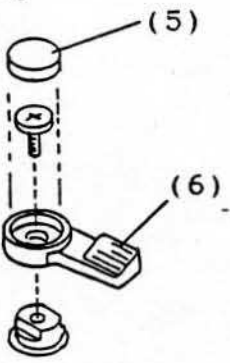
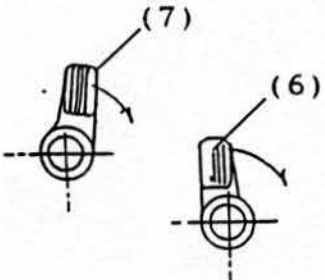
Sketch	Explanation
<p>[Figure 1]</p> 	<p>Right cover removal</p> <ol style="list-style-type: none"> 1. Remove the film winding crank (1). 2. Peel off the leatherette (2) and remove the crank base (3) and crank ring (4). <p>Screws: panhead type 1 (95813605) M1.7x6-Ni x 4 screws ----- [Figure 1]</p> <div style="border: 1px solid black; padding: 5px; margin-top: 10px;"> <p>* Reassembly notes</p> <ul style="list-style-type: none"> o Lightly coat the crank ring spring with grease. <p>Grease: Liqui-Moly LM-83</p> <ul style="list-style-type: none"> o Carefully align the position of the 4 holes and fasten with 4 screws. <p style="text-align: center;">Grease</p>  </div>
<p>[Figure 2]</p> 	<ol style="list-style-type: none"> 3. Peel off the cover (5) and remove the mirror up lever (6) and multiple exposure lever (7). <p>Screws: Special panhead (01162230) M1.7x2.5-B x 2 screws ----- [Figure 2]</p>
<p>[Figure 3]</p> 	<div style="border: 1px solid black; padding: 5px;"> <p>* Reassembly notes</p> <ul style="list-style-type: none"> o Make sure that the levers (6) (7) are installed in the correct locations. <p style="text-align: right;">----- [Figure 3]</p> <ul style="list-style-type: none"> o Adhere the cover with adhesive. <p>Adhesive: Plio-Bond</p> </div>

Sketch

Explanation

[Figure 4]

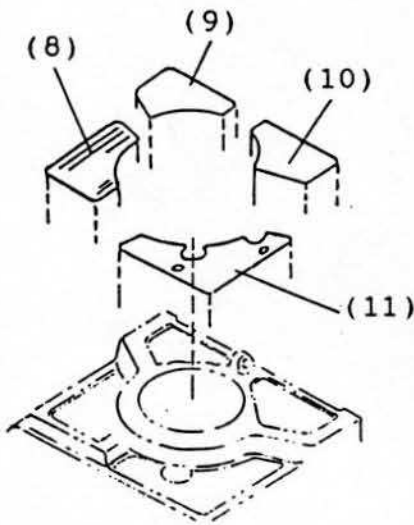

4. Remove leatherette (8), (9), (10) and (11).

--- [Figure 4]

[Figure 5]

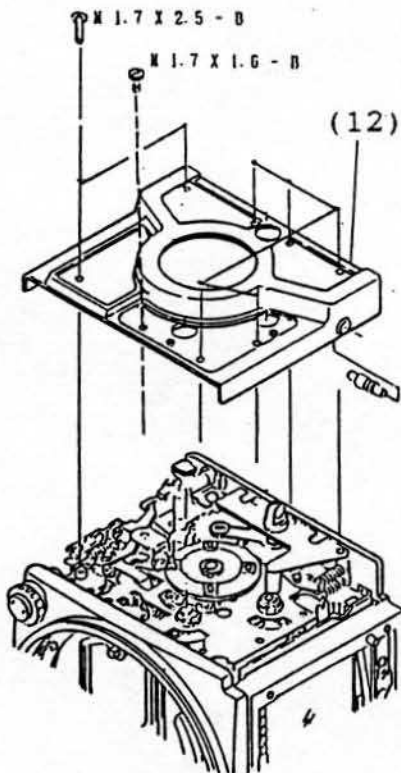

5. Remove the 8 screws from the cover (R) (12).

Screws: panhead type 1 (95813257)
 M1.7x2.5-B x 7 screws
 panhead type 1 (95813167)
 M1.7x1.6-B x 1 screw

--- [Figure 5]

* Reassembly notes

o Use caution concerning screw length.



Short screw:
1 location

o The leatherette (8) is adhered with the stick paper. During reassembly, adhere it using adhesive.

o Concerning the other leatherettes, check the adhesion of the stick papers and adhere them with the adhesive if necessary.

Adhesive: Plio-Bond

Sketch

Explanation

[Figure 6]

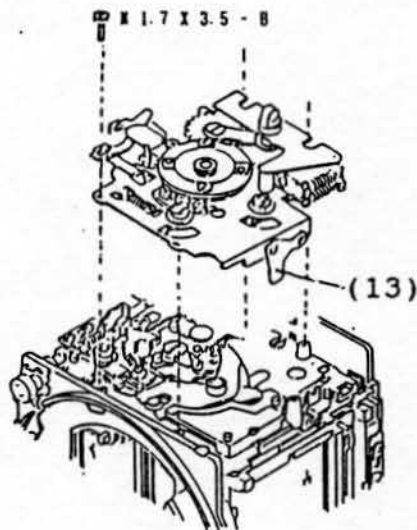
Winding unit removal

1. Remove the 5 screws.

Screws: panhead type 1 (95813357)
M1.7x3.5-B x 5 screws

Note: Release the shutter before removing the winding unit.

--- [Figure 6]

2. Position the mirror up lever and multiple exposure lever horizontally and remove the unit, using caution concerning the ME. display plate (13).

Note: The winding stopper holder (14) and winding stopper lever (15) are coupled; therefore, press down as indicated by the arrow.

--- [Figure 7]

[Figure 7]

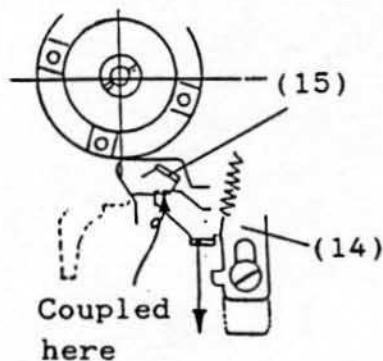

[Figure 8]

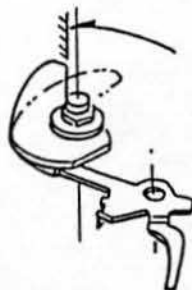

[Figure 9]

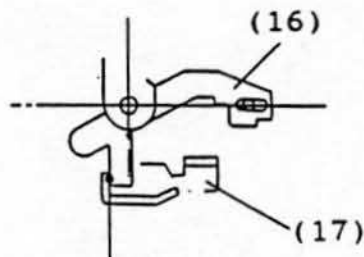

Couple here!

× Reassembly notes
- Procedure-

- 1) Release the body shutter.
- 2) Reinstall the winding unit in the body in the winding stop.
--- [Figure 8]
- 3) Be careful not to bend the ME. display plate during reassembly.
- 4) As with disassembly, avoid catching of the winding stopper holder (14) and winding stopper lever (15).
- 5) Couple the mirror up plate (16) and mirror up operating plate (17).

--- [Figure 9]

Sketch

Explanation

[Figure 10]

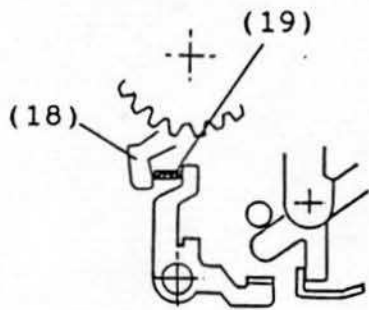

Winding unit removal

- 6) Couple the multi operating plate (18) and F. release board (upper) (19).

--- [Figure 10]

- Procedure -

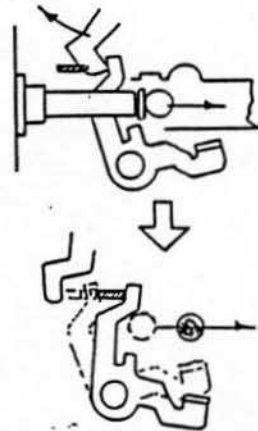

- 7) Check the link coupling described above and fasten the winding unit with 5 screws.

[Figure 11]

Grease: LM-83

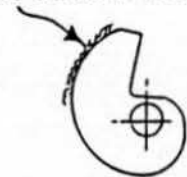

Grease: LM-83



Grease: 023

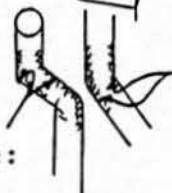

Grease: 023

Grease: LM-83

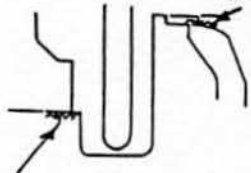

Grease: LM-83

Don't forget to lubricate!

- o After disassembly as described above, coat the parts shown in [Figure 11] with grease.

- * The 6 locations shown in [Figure 11] are important for maintaining the durability of the camera.

Grease: Liqui-Moly LM-83
Photolub 023

Sketch

Explanation

[Figure 12]

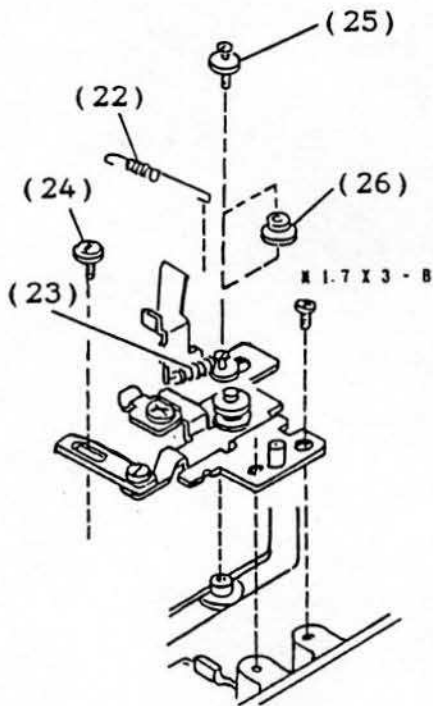

[Figure 13]

At least 1/3 the length should be coupled.

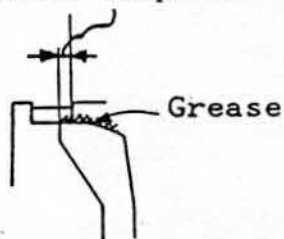

[Figure 14]

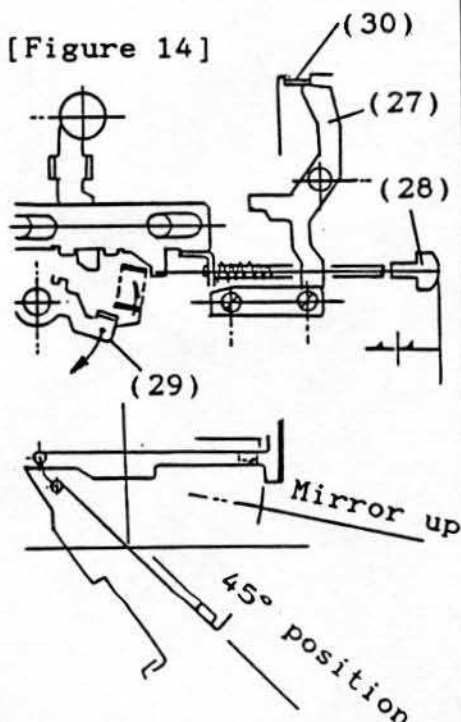
S. latch set removal

1. Remove the release return spring (22) and winding stopper holder spring (23).
2. Remove the release link screw (24) and stud screw (25), then remove the 2 screws and remove the entire unit.

Screws: panhead type 1 (95813307)
M1.7x3-B x 2 screws

Note: Do not remove the winding stopper guide (26).

--- [Figure 12]

* Reassembly notes

- 1) Align with the body mounting holes and reinstall the S. latch set.
- 2) Coat the end of the S. latch (27) with grease.

Grease: Liqui-Moly LM-83

--- [Figure 13]

- Operation check -

- 1) Slide the mirror operating board (30) upward to couple the S. latch (27).

--- [Figure 14]

- 2) Move the F. winding safety lever (29) in the direction of the arrow and test by pressing the shutter release button (28).

o Pressing the shutter release button partially causes the mirror to raise. Pressing the shutter release button farther causes the tight plate to move fully upward.

- 3) Check the operating when the shutter release button is returned slowly.

- 4) Do not press the shutter release button while the F. winding safety lever is removed.

Sketch

Explanation

[Figure 15]

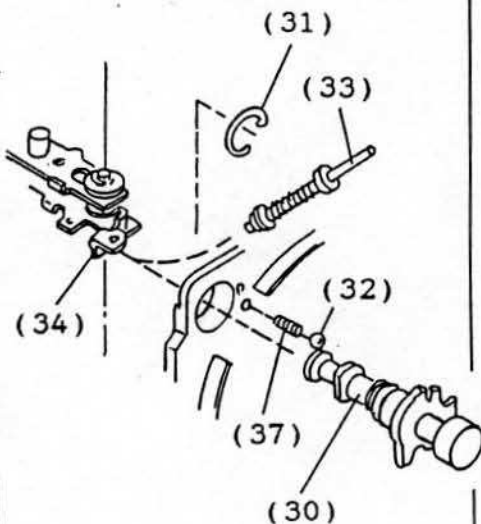
Shutter release button removal

* The shutter release button can only be removed after the front cover is removed.

--- See page 28.

1. Remove the C-ring (31) and remove the S. button set (30).

Note: Use care since the click ball (32) may spring out when released.

Click ball: $\phi 2$. steel ball
(905770010)

2. Remove the release rod set (33).
--- [Figure 15]

[Figure 16]

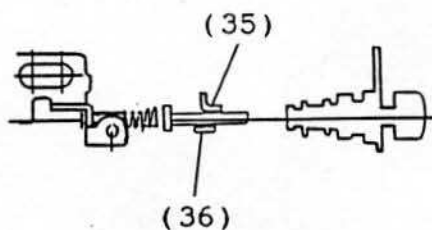

* Reassembly notes

- 1) Insert the release rod set into the hole in the release holder plate (34).
 - o Couple the S. button lock lever (35) and release lever (36).
--- [Figure 16]
- 2) Insert the S. button set into the hole in the side of the body and couple to the release rod set.
- 3) Install the click spring (37) and click ball (32) and fasten with a C-ring.

C-ring: CE-6 stopper ring
(01252270)

- 4) Coat the shutter release button slide with grease.

Grease: Liqui-Moly LM-83
Losimol 13L

--- [Figure 17]

[Figure 17]

Grease: LM-83

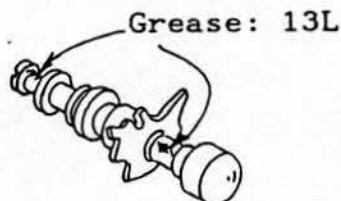
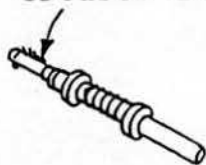

Sketch

Explanation

[Figure 18]

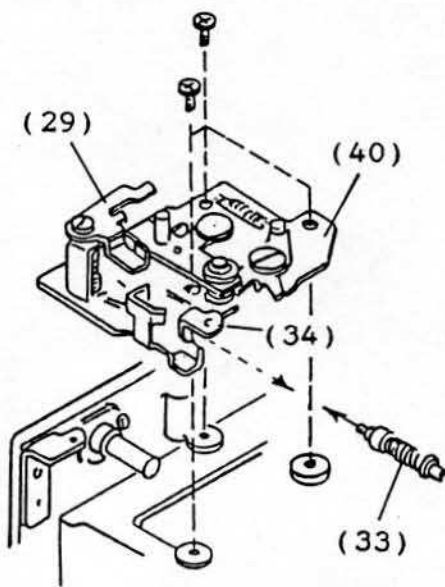

E. release unit removal

1. Remove the 3 screws, uncouple the release rod set (33) and release holder plate (34) and then remove the entire unit (40).

--- [Figure 18]

- Procedure -

- o Move the F. winding safety lever (29) in the direction of the arrow and uncouple the release holder plate (24) and release rod (33) by moving them as indicated by the arrows.

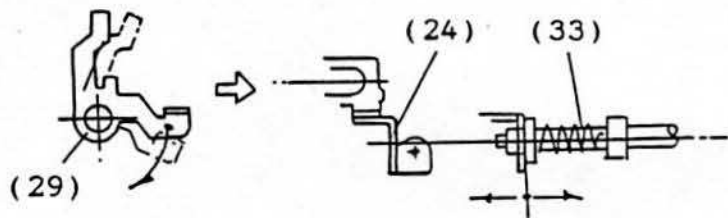

[Figure 19]

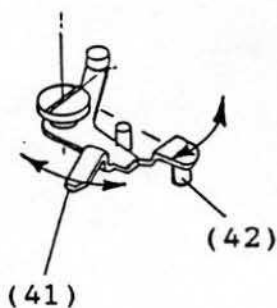

* Reassembly notes

- o First, recouple the release rod by reversing the disassembly procedure and fasten with 3 screws.

Screws: panhead type 1 (95813307)
M1.7x3.0-B

- Operation check -

- 1) Check if the F. release lever (upper) (41) and F. release lever (lower) (42) operate smoothly without binding. --- [Figure 19]
- 2) Slowly slide the mirror operating board (30) from the top to the bottom and use the position where it stops as the "mirror up position." --- [Figure 20]
- 3) The gap between the F. release pin (43) and F. release board pin (44) shall be 0.5 - 0.8mm. When the gap is not within this range, adjust by bending the winding release lever (top).

[Figure 20]

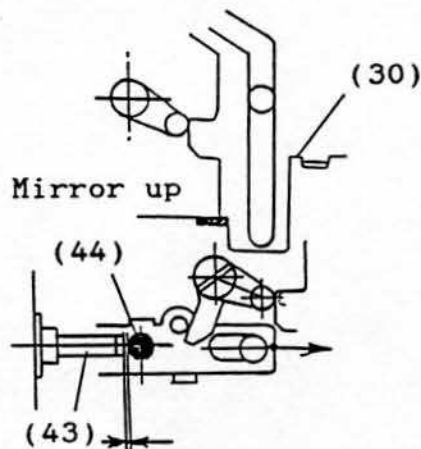

0.3 ~ 0.8mm

0.3 ~ 0.8mm



Bend here!

Sketch

Explanation

[Figure 21]

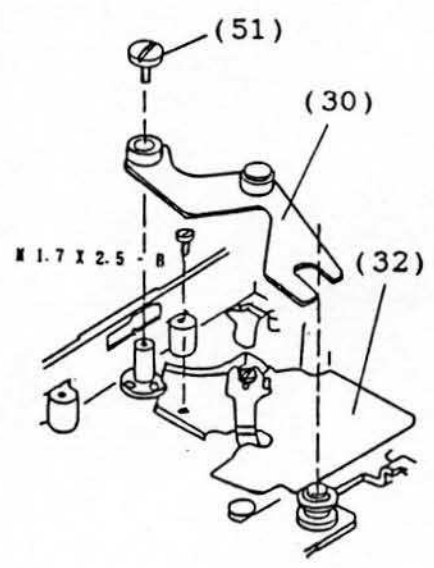

[Figure 22]

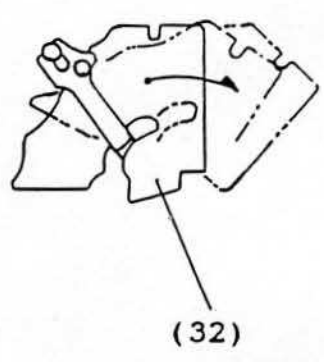

Set lever removal

1. Remove the special ascrew (51) and remove the set lever.

Note: The special screw has left-hand threads.

Special screws: M1.7x3.5 (left)
 (01251561) x 1 screw
 --- [Figure 21]

2. Be careful to bend the light tight frame (32).

Screws: panhead type 1 (95813207)
 M1.7x2.5-B x 2 screws

- Procedure -

- 1) As shown in [Figure 22], the light tight frame must be removed while rotating it in the direction of the arrow with the shutter released.

* Reassembly notes

- o Reassembly is difficult because the end of the light tight frame (A) is restricted by the protrusion of the body die casting; therefore, lift up the end (A) with tweezers when reassembling.

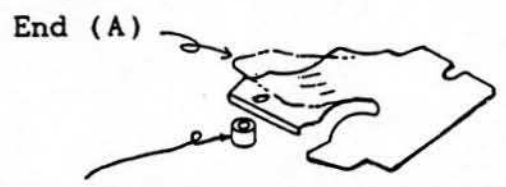

- o When the light tight frame is repaired after being bent, check that it does not contact the set lever and mirror operating board.

Sketch

Explanation

[Figure 23]

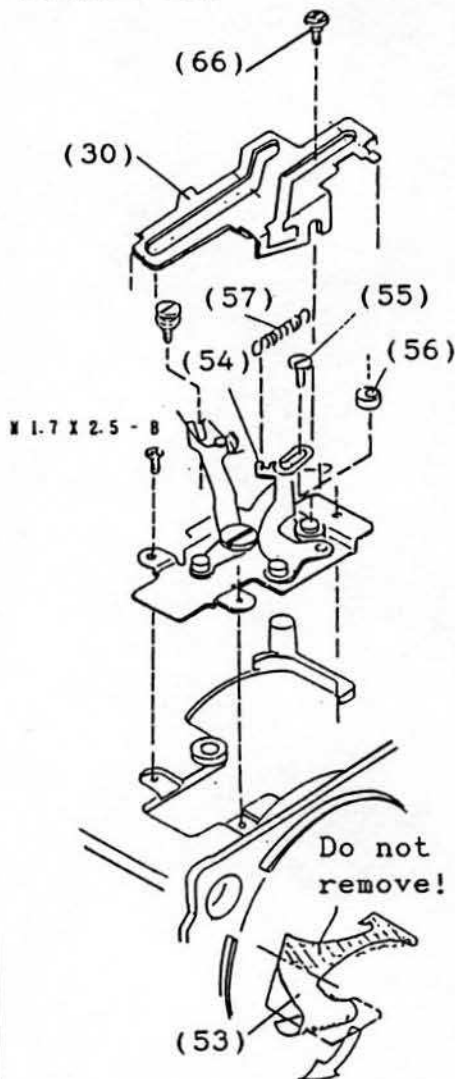

Peel off (53)
as described above.

[Figure 24]

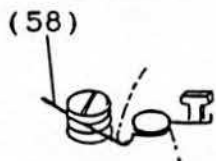

[Figure 25]

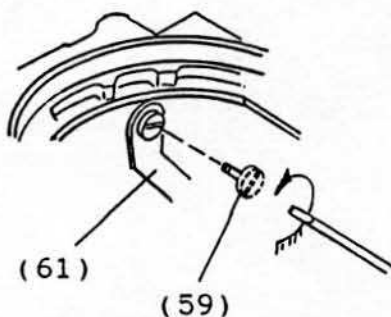
**Mirror operating lever removal**

1. Peel off the light baffle (53) inside the body to the extent that the disassembly can be carried out. Uncouple the mirror operating lever (54) and mirror frame.

Disassemble in the following sequence:

- 1) M. arm adjusting screw (55)
 - 2) M. arm adjustment cam (56)
 - 3) Spring (57).
2. Remove the screws (66) fastening the mirror operating plate (30).
--- [Figure 23]
 3. Disengage the spring (58).
--- [Figure 24]
 4. Use a long screwdriver to remove the mirror arm screw (right) (59) from the body interior through the mount.
--- [Figure 25]
 5. Remove the 3 screws fastening the M. operating base board unit.

Screws: panhead type 1 M1.7x2.5-B x
3 screws

* Reassembly notes

- 1) The mirror operating lever is fastened by 3 screws.
- 2) The M. arm (61) and M. operating lever (54) are fastened by the mirror arm screw (right).
- 3) Temporarily fasten the M. arm adjusting cam with the M. arm adjusting screw (55) and engage the spring (57).

Sketch

Explanation

[Figure 26]

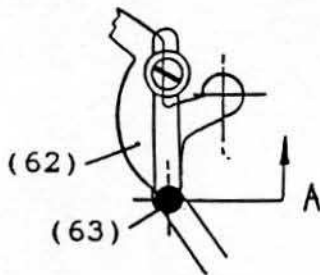

[Figure 27]

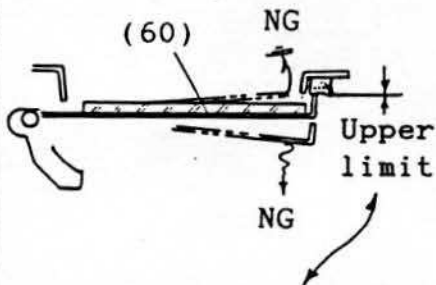

- * Compress the sponge as far as there is resilience.

[Figure 28]

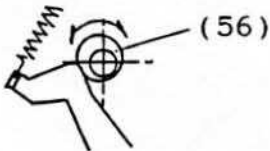

[Figure 29]

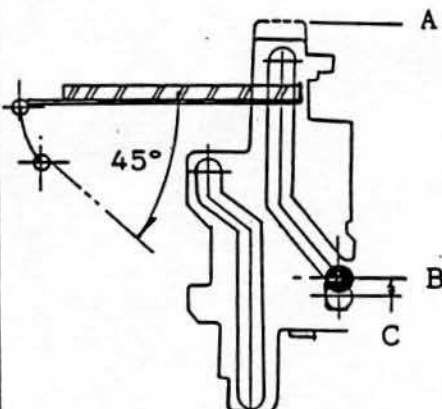

- A: mirror up position upper limit
- B: mirror operation stop position
- C: margin at end of operation

[Figure 30]

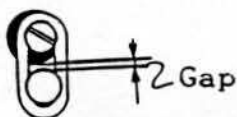

- * Reassembly notes (continued)

*2 Adjust the M. frame and light tight plate with the M. operating board installed and after adjusting the M. frame.

- o The light tight plate must be uncoupled and free.

*3 Adjustment is easier with the F. release unit and S. latch unit installed because of their mutually related operation.

1. M. frame (60) adjustment

Slide the M. operating plate downward until the collar (63) of the mirror operating lever (62) moves beyond the cam of the mirror operating plate (30) to position (A).

--- [Figure 26]

2. Move the M. arm adjusting cam (56) so that the M. frame moves upward to the upper limit (the mirror frame should not sag). Lock with the M. adjusting screw so that the adjustment is not disturbed.

--- [Figure 27] [Figure 28]

3. With the mirror lowered to the 45° position, the relationship between the cam slot of the M. operating board and M. operating lever roller shall be as shown at position B and there shall be a gap between the M. operating lever and mirror arm adjusting cam.

--- [Figure 29]

Check that any play in the link mounted on the mirror drive lever is absorbed by the operational allowance.

--- [Figure 30]

*4 When this play cannot be absorbed, the mirror frame is adjusted too high.

Sketch

Explanation

[Figure 31]

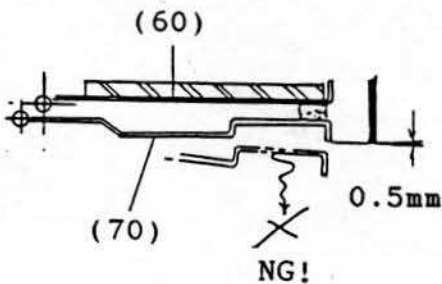

[Figure 32]

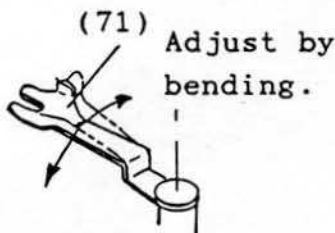

[Figure 33]

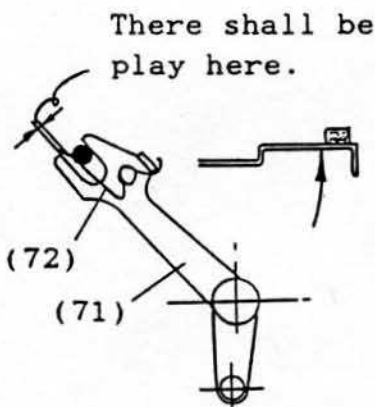

[Figure 34]

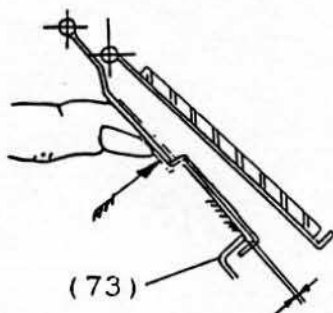

About 0.5mm at the end.

(Continued)

4. Light tight frame (70) adjustment

With the spring (58) engaged, raise the mirror frame (60) and light tight frame (70).

- o The light tight frame shall be in intimate contact with the sponge (69) on the back of the mirror frame when raised to the upper limit.

*5 Sag of up to 0.5mm is acceptable, looking from the front of the body.

--- [Figure 31]

- o When the light tight frame does not rise far enough, adjust by bending the light tight frame lever (71).

Note: Use care since bending too far can cause excessive friction in the cam slot of the mirror operating plate (the shutter will not release).

--- [Figure 32]

- Post-adjustment checks -

1. With the light tight frame raised

- o Check if there is play between the light tight frame lever and pin and that the force of the spring (72) acts upward.

--- [Figure 33]

2. With the light tight frame lowered

- o With the mirror operating plate at the upper limit, the light tight frame shall operate smoothly and stop in intimate contact with the rear light tight frame (73).

- o It is desirable that there should be approximately 0.5mm of play when the light tight frame is pushed from the back.

--- [Figure 34]

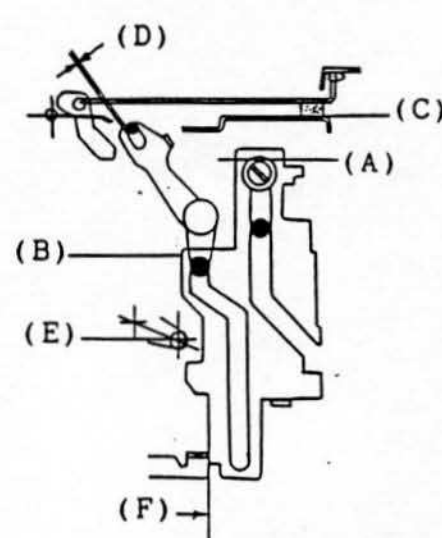
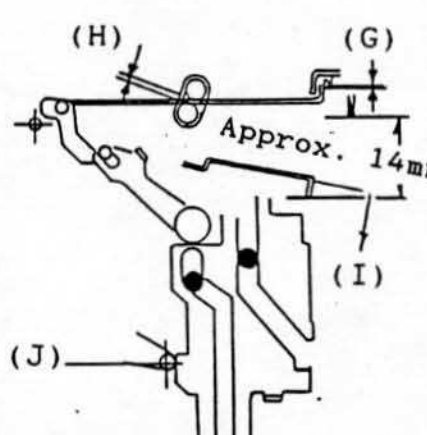
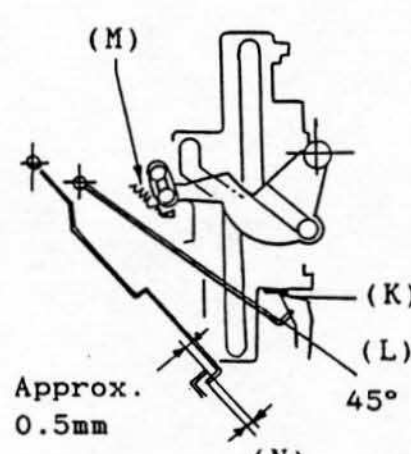
Sketch	Explanation
<p>[Figure 35]</p> 	<p>- Related operations -</p> <p>With the M. frame and light tight frame raised</p> <p>(A) (B) The mirror operating board shall drop to the operating limit.</p> <p>(C) The back of the M. frame (sponge) shall be in intimate contact.</p> <p>(D) There shall be a slight gap between the M. frame and the arm pin.</p> <p>(E) The rollers shall be free.</p> <p>(F) The M. up-stopper plate shall be in contact with the operating plate.</p> <p style="text-align: right;">--- [Figure 35]</p>
<p>[Figure 36]</p> 	<p>With the mirror up</p> <p>(G) (H) With the M. frame up, the mirror shall raise and remain at the position of the sponge adhered to the screen light baffle frame.</p> <p>(I) The light tight frame shall stop at approximately 14mm.</p> <p>(J) The F. release collar shall be positioned at the mirror operating plate cam.</p> <p style="text-align: right;">--- [Figure 36]</p>
<p>[Figure 37]</p> 	<p>With the mirror frame and light tight frame lowered</p> <p>(K) (L) The M. operating board shall couple with the S. latch and stop.</p> <p>(M) The spring of the mirror operating lever shall be extended and held in the 45° position.</p> <p>(N) The light tight frame shall lower to the rear light tight frame and stop.</p> <p>* It is desirable that there be approximately 0.5mm of play. Excessively close contact increases the operational load.</p> <p style="text-align: right;">--- [Figure 37]</p>

(E T R S i)

Sketch

Explanation

[Figure 38]

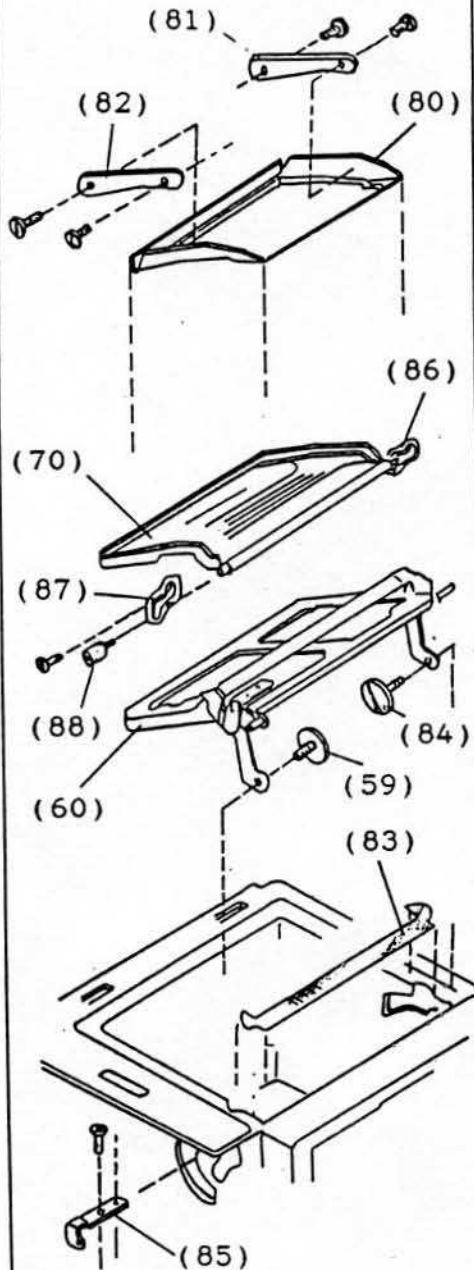
**Mirror frame and light tight frame removal**

1. Remove the rear light tight frame (80).

- o Remove the 2 screws at the bottom of the F. release unit and the 2 screws at the bottom of the left side shutter circuit board and remove the frame metal (L) (R) (81) (82).
- o Remove the sealant used to prevent light leaks around the rear light tight frame.
- o Use care to avoid bending the light tight frame during removal.

2. Peel off the light tight cloth (83) and remove the 2 screws fastening the light tight plate arm (85).

- o Remove the each two screws (59) (84) fastening the left and right mirror arms from inside the body.
- o Remove the screws fastening the left and right mirror operating guide plate (86) (87) and the stud screw (88); then remove the M. frame (60) and the light tight frame (70) at the same time.

--- [Figure 38]

(ETRSi)

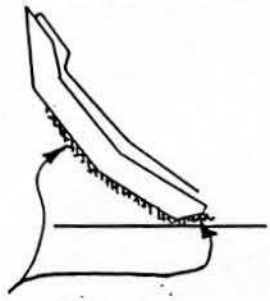
Sketch	Explanation
<p data-bbox="216 223 420 259">[Figure 39]</p>  <p data-bbox="294 673 431 704">Sealing</p>	<p data-bbox="780 269 1121 300">* Reassembly notes</p> <p data-bbox="780 331 1426 424">1) Reassemble the M. frame and light tight plate together with the M. guide plate as a set.</p> <p data-bbox="838 455 1466 590">Grease: Liqui-Moly LM-83 Screws: panhead type 1 (95813307) M1.7x3.0-B x 1 screw each left and right</p> <p data-bbox="780 611 1450 683">2) Mount the rear light tight frame on the frame metal.</p> <p data-bbox="838 714 1466 839">Screws: panhead type 1 (95813307) M1.7x3.0-B x 2 screws panhead type 1 (95813357) M1.7x3.5-B x 2 screws</p> <p data-bbox="780 859 1395 963">3) Apply sealant around the rear light tight frame to prevent light leaks.</p> <p data-bbox="838 994 1458 1087">Sealant: Three-Bond Liquid Gasket 1103 (black) --- [Figure 39]</p>

Sketch

[Figure 40]

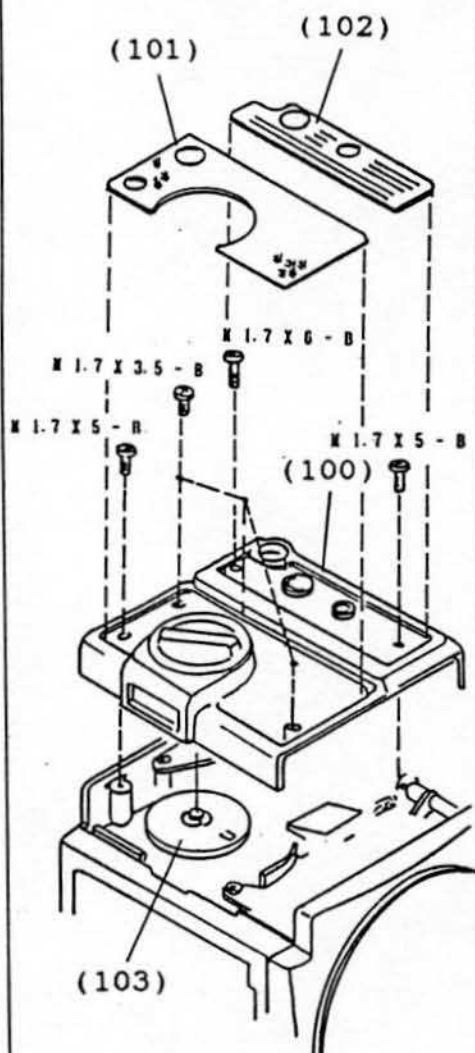

Explanation

Cover set (L) removal

1. Peel off the left cover leatherettes (101) (102).
2. Remove the 6 screws.

--- [Figure 40]

* Reassembly notes

- o Install the left cover (100) so that the S. brush plate (103) and SD knob are coupled.

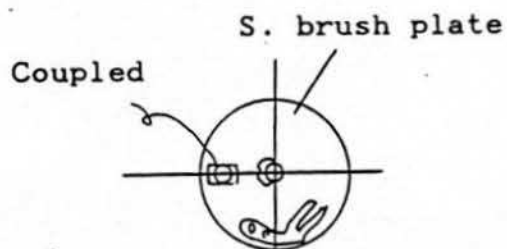

- o During reassembly, check the screw length.

Panhead type 1 (05813357)
 M1.7x3.5-B x 3 screws
 Panhead type 1 (05813507)
 M1.7x5-B x 2 screws
 Panhead type 1 (05813607)
 M1.7x6-B x 1 screw

- o Use adhesive to adhere the leatherette (102).

Adhesive: Plio-Bond

- * Stick paper is used during production at the factory. When making repairs, use an adhesive of suitable strength.

Circuit board names and wiring diagram 1

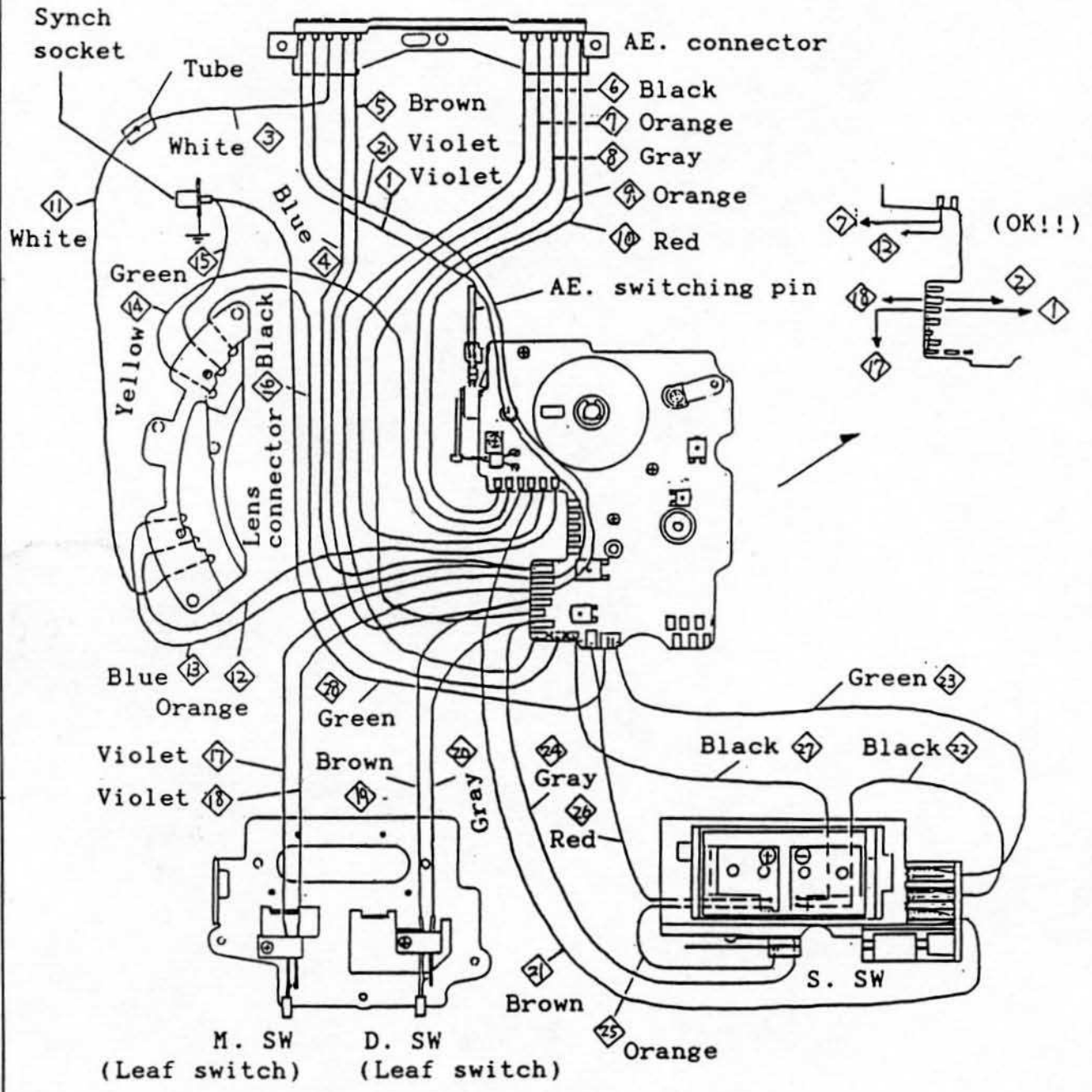

[Figure 42]

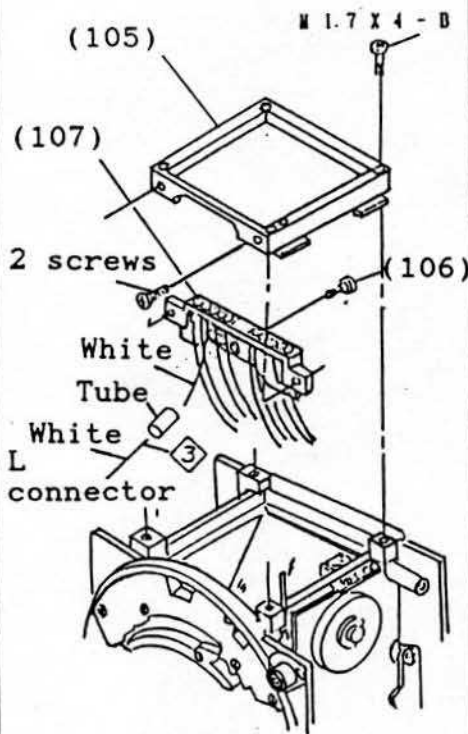

Upper frame/AE. connector removal

1. Remove the upper frame set (105).

* The upper frame set cannot be removed unless the left and right front covers are removed.

--- Refer to pages 1, 15 and 28.

Screws: panhead type 1 (95812407)
M1.7x4-B x 4 screws

Remove the wiring cover and wiring holder.

Refer to page 19.

Remove the AE. connector screw (106) and 2 other screws.

Screws: self-tapping screw flat head type 1 (95893407) M1.7x4-B x 2 screws

Note: Be careful to avoid galling with the AE. connector screw.

--- [Figure 42]

2. Disconnect the wires.

1) Disconnect the wires <1>, <2>, <4>... <19> from the shutter circuit board.

--- [Figure 43]

2) Disconnect wire <3> at the tube.

--- [Figure 42]

3) Remove the AE. connector (107), using care not to damage any dangling wires.

[Figure 43]

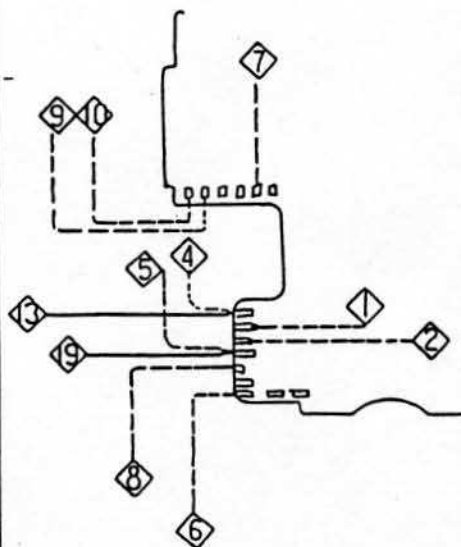

* Reassembly notes

1. Make sure the wiring is correct.

2. Avoid shorts (due to pinching of wires, etc.).

Sketch

Explanation

[Figure 44]

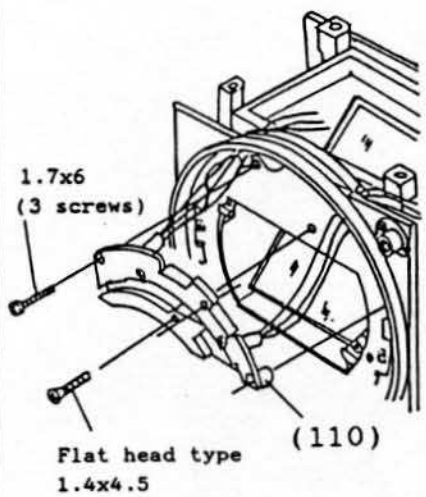

Lens connector removal

1. Remove the 4 screws fastening the lens connector (110).

Screws: panhead type 1 (95813607)
 M1.7x6-B x 3 screws
 flat head type 1 (95831457)
 M1.4x4.5-B x 1 screw
 --- [Figure 44]

2. Disconnect the wires.

- 1) Disconnect wires <15> from the synch socket.
 --- [Figure 45]

- 2) Disconnect wires <12>, <13>, <14>, <16> connected on the lens connector side from the S. circuit board.
 --- [Figure 46]

- 3) Remove the lens connector (110), using care to avoid damaging wires.

[Figure 45]



[Figure 46]

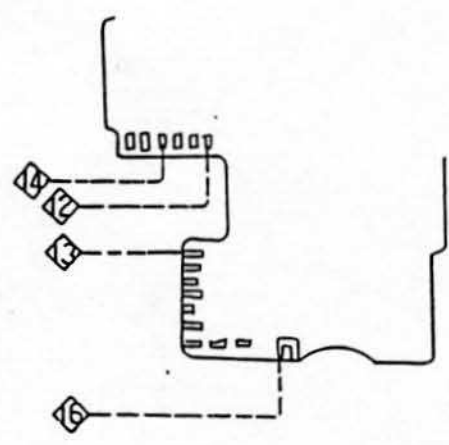

* Reassembly notes

1. Make sure the wiring is correct.
2. Avoid shorts (due to pinching of wires, etc.).
3. Solder correctly.
4. Tighten all screws firmly and avoid stick.
5. Do not pull on wires more than necessary (because the connector pin on the lens connector side requires margin to move up and down).

Sketch

Explanation

[Figure 47]

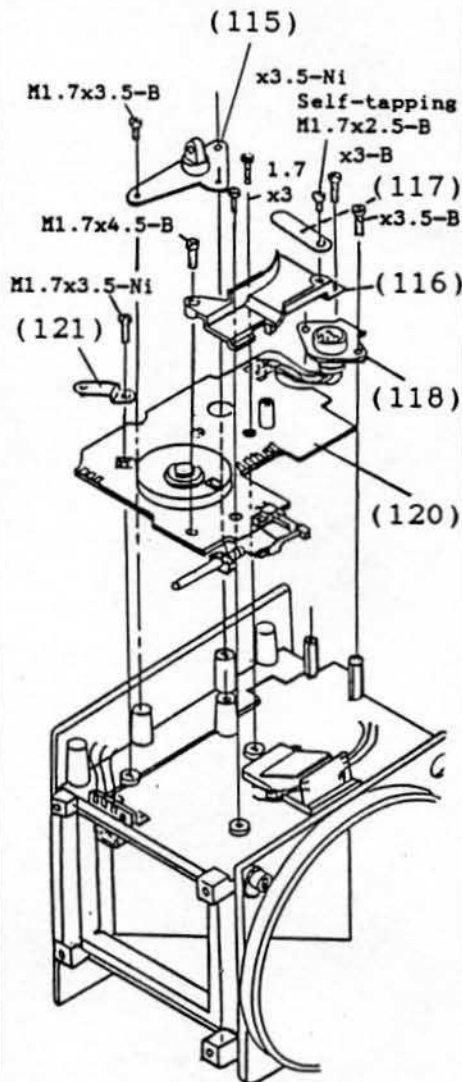

[Figure 48]

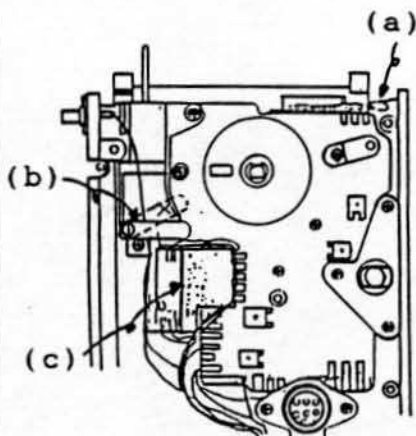
Shutter circuit unit removal

1. Disconnect the wiring.

Disconnect all wires other than the SCA. connector.

2. Remove the strap ring (L) (115).

Screws: panhead type 1 M1.7x3.5-B x 3 screws

Remove the wiring cover (116) and wiring holder (117).

Screws: panhead type 1 (95813457) M1.7x4.5-B x 1 screw
panhead type 1 (95813307) M1.7x2.5-B x 1 screw
self-tapping panhead type 1 (95873257) M1.7x2.5-B x 1 screw

Remove the SCA. connector (118).

Screws: panhead type 1 (95813357) M1.7x3.5-B x 2 screws

3. Remove the shutter circuit unit (120).

Screws: panhead type 1 (95813307) M1.7x3.5-B x 1 screw
panhead type 1 (95813355) M1.7x3.5-Ni x 2 screws

When the B.C. contact (121) is removed, the shutter circuit unit can be removed with the SCA. connector attached.

--- [Figure 47]

* Reassembly notes

1. Make sure the wiring is correct.
2. Avoid shorts (due to pinching of wires, etc.).
3. Repair cords.
 - o Dress the LED wires toward the back. (a)

Sketch

Explanation

- o Do not allow the wiring holder to ride above the wiring cover wall at the curved part. (b)
 - o Dress the sensor circuit board wires beside the sensor holder (because it will hit the left cover if it rides up on the sensor holder). (c)
- [Figure 48]

[Figure 49]

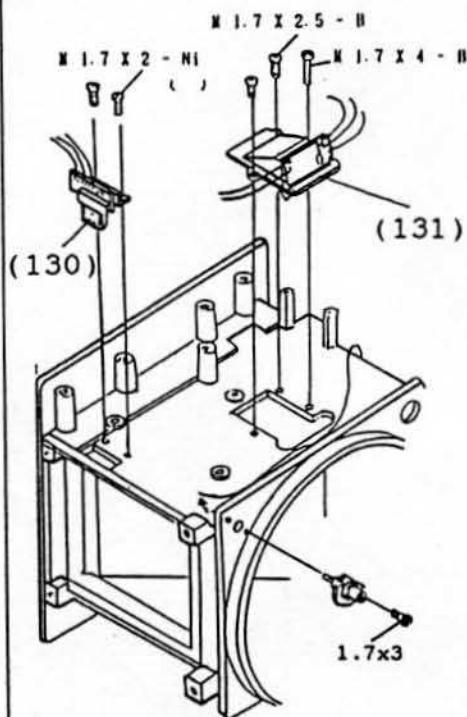
Display set/sensor unit/synch socket removal

1. Remove the display set (130).
Screws: panhead type 1 (95813205)
M1.7x2-Ni x 2 screws
2. Remove the sensor unit (131).
Screws: panhead type 1 (95813257)
M.7x2.5-B x 2 screws
panhead type 1 (95813407)
M1.7x4-B x 1 screw
--- [Figure 49]
3. Remove the synch socket (132).
Screws: panhead type 1 (95813305)
M1.7x3-Ni x 2 screws
4. Disconnect wire <28> (green).
--- [Figure 50]

[Figure 50]

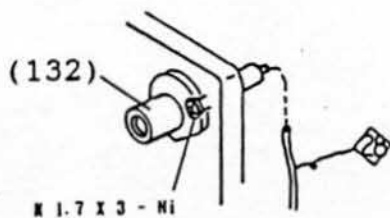

* Reassembly notes

1. Avoids shorts (due to pinching of wires, etc.).
2. Solder correctly.

(E T R S i)

Sketch	Explanation
	<p><u>MEMO</u></p>

Sketch

Explanation

[Figure 51]

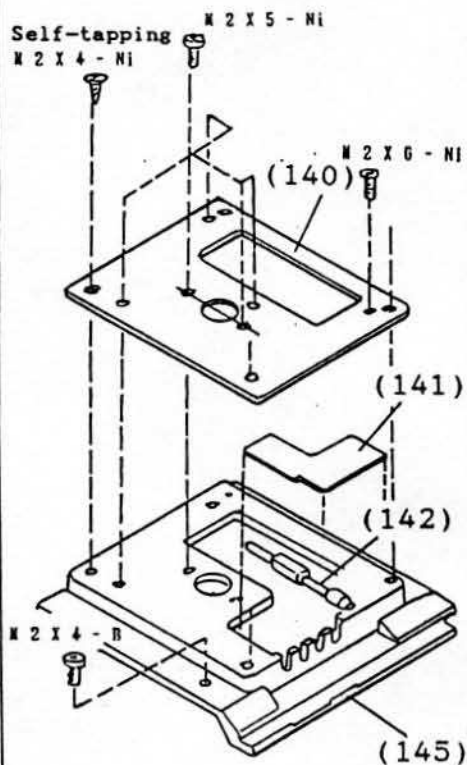
Tripod shoe removal

1. Remove the 10 screws and remove the tripod shoe (140).

Screws: self-tapping screw flat head type 1 (95895405) M2x4-Ni x 4 screws
 flat head type 1 (95835505) M2x5-Ni x 5 screws
 flat head type 1 (95835605) M2x6-Ni x 1 screw

2. Remove the MD. connector cover (141) and bottom release shaft (142).

3. Remove the 2 screws and remove the bottom cover (145).

Screws: panhead type 1 (95815407) M2x4-B x 2 screws

Note: The bottom cover cannot be removed unless either the left or right cover is removed first.
 --- [Figure 51]

[Figure 52]

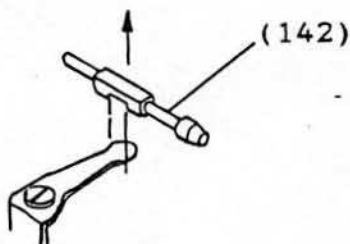

* Reassembly notes

1. Reinstall the bottom release shaft.

--- [Figure 52]

Note: Make sure that B. release shaft is in the center of the U-groove in the bottom cover. If the shaft is not centered, adjust by slightly shifting the battery box installation position.

--- [Figure 53]

[Figure 53]

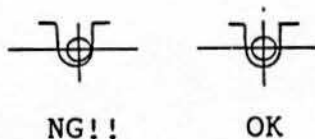

2. Reinstall the MD. connector cover.

3. After fastening the bottom cover with the 2 screws, install the tripod shoe. Make sure that all screws are firmly tightened. Loose screws will interfere with motor winder installation.

Sketch

Explanation

[Figure 54]

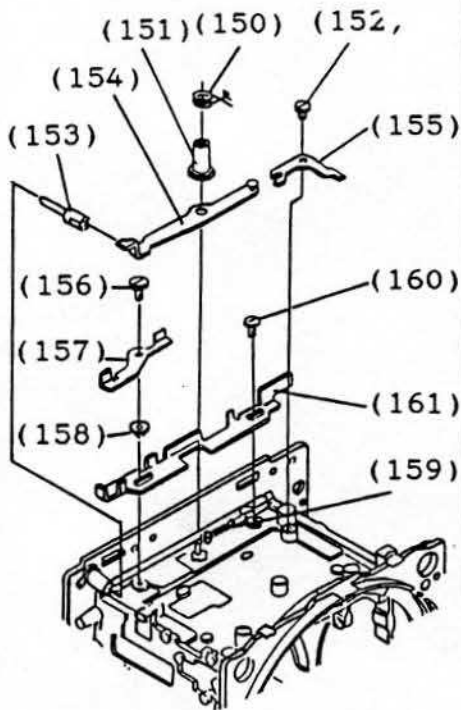
Film backs exchange function removal

1. Remove the D. safety lever (154) and safety latch (155) in the following sequence.

- 1) Spring (150).
- 2) Holder (151).
- 3) Special screw (152).
- 4) Connecting pin (153).
- 5) D. safety lever (154).
- 6) Safety latch (155).

2. Remove the L. safety lever (157) and back release link (161) in the following sequence.

- 1) Special screw (156).
- 2) L. safety lever (157).
- 3) Guide collar (158).
- 4) Remove the spring (159) on the link side.
- 5) Guide screw (160).
- 6) Back release link (161).

--- [Figure 54]

[Figure 55]

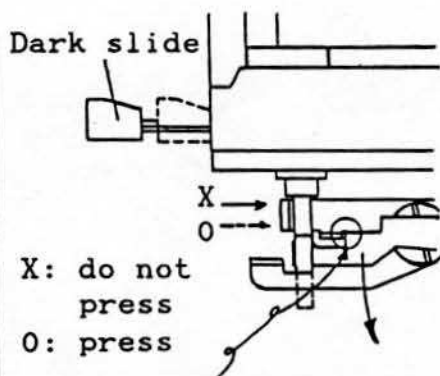

X: do not
press
O: press

This section is locked
so do not press.

* Reassembly notes

1. After installing (150), use adhesive to lock the end on the inside of the rear surface of the body.
2. Reassemble in sequence, testing the operation of each lever.
3. With the dark slide inserted and the back mounted, make sure that relay is not possible. Also make sure that the back can easily be detached by pressing the back release button.

It shall not be possible to press the back release button or remove the back with the dark slide removed.

When a Poraroid film back E is mounted, the shutter shall release only in the multiple exposure mode.

It shall be possible to remove the back either before or after the shutter is released if the dark slide is inserted.

Note: Check item 3 after installing the left cover.

--- [Figure 55]

Sketch

[Figure 56]

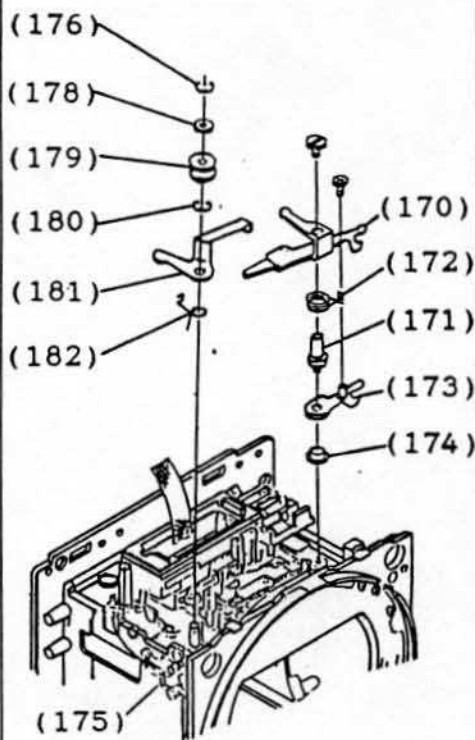

[Figure 57]

The S switch shall be turned on by stroke 1.

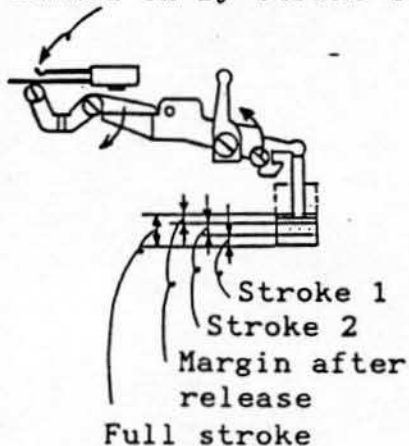

Explanation

Shutter release function removal

1. Remove the release lever (170) and S. button lock (173) in the following sequence.

Screws: special panhead type
(95022102) M1.4x1.8-Ni x 1 screw
special panhead type 1
(95023182) M1.7x3.0-Ni x 1 screw

- 1) Release lever (170).
 - 2) Release lever shaft (171).
 - 3) Spring (172).
 - 4) S. button lock (173).
 - 5) Collar (174).
2. Remove the release relay lever (181) in the following sequence.
 - 1) Remove only the operating ring spring (175) only on one side (where indexed.)
 - 2) E-ring (E-17) (176) (955017440).
 - 3) Washer: I.D.: 2.1mm, O.D.: 6mm. t=0.3 (178) (95520631).
 - 4) Roller (179)
 - 5) E-ring (JE-2.5) (180) (95502244).
 - 6) Release relay lever (181).
 - 7) Spring (182).

[Figure 56]

* Reassembly notes

Reassemble in sequence, testing the operation of each lever.

Note: Release button stroke

Stroke 1: the S. switch is turned on (approx. 1.1mm)

Stroke 2: the shutter release position (approx. 1.4mm)

Margin after shutter release: approx. 0.7mm

Full stroke: approx. 3.2mm

Note: The S switch shall not turn on with the front cover installed and the shutter release button locked.

--- [Figure 57]

Sketch

Explanation

[Figure 58]

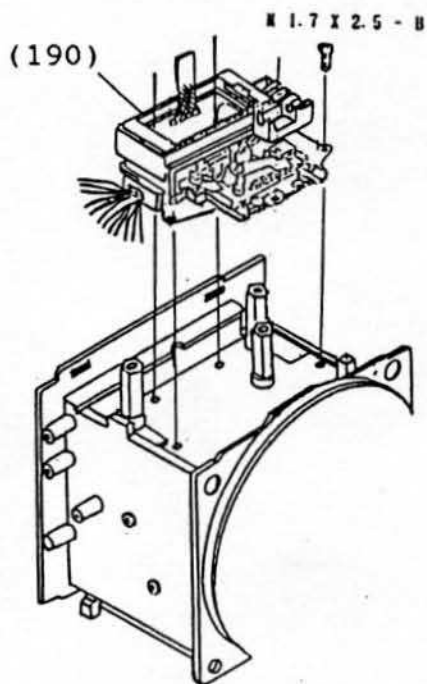
Battery box removal

1. Remove the 5 screws and remove the battery box (190) as a unit.

Screws: panhead type 1 (95813257)
M1.7x2.5-B x 5 screws

--- [Figure 58]

* Reassembly notes

1. Do not allow the wires to become pinched.
2. Clean all switches.

[Figure 59]

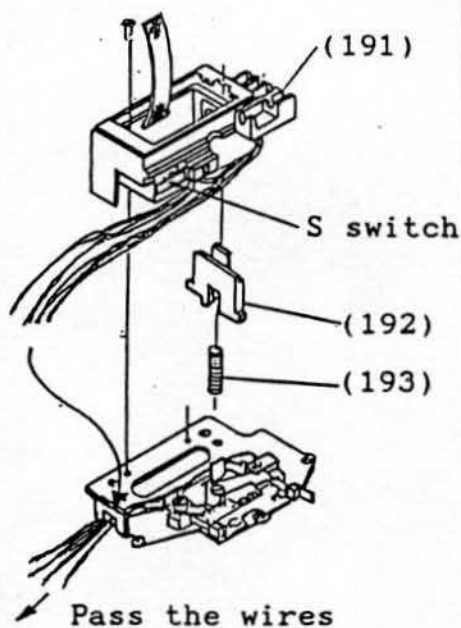

To remove only the battery box (191)

- 1) Remove the 4 screws inside the battery box and remove the battery box.

Screws: panhead type 1 (95813257)
M1.7x2.5-B x 4 screws

- 2) Remove the battery chamber cover lock (192) and B. spring (193).

--- [Figure 59]

* Reassembly notes

- o Make sure the battery chamber cover lock is installed in the proper direction.
- o Be careful to avoid pinching wires and bending the S. switch during reassembly.

--- [Figure 60]

[Figure 60]

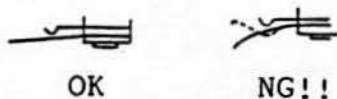

OK

NG!!

Sketch	Explanation
--------	-------------

[Figure 61]

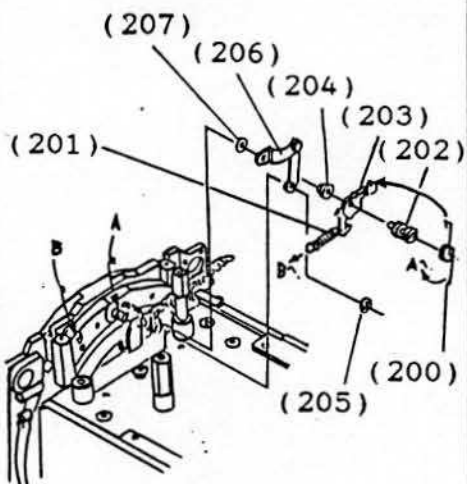

Brake mechanism removal

1. Remove the brake spring lever (203) and brake link ass'y (206) in the following sequence.

- 1) Spring (200).
- 2) Spring (201).
- 3) Brake lever axle (202).
- 4) Brake spring lever (203).
- 5) Link B axle (204).
- 6) E-ring (E-13) (205) (95500334).
- 7) Brake link ass'y (206).
- 8) Washer (I.D.: 1.8mm, O.D.: 5mm. t=0.3) (207) (95511031).

— [Figure 61]

[Figure 62]

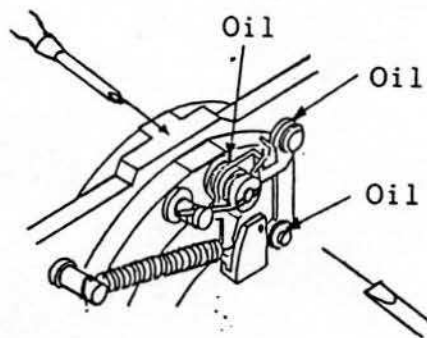

* Reassembly notes

- o Reassembly is possible by reversing the disassembly procedure but reassemble in sequence while checking for smooth operation of all links.
- o When removing and then reinstalling the brake lever shaft, hold the shaft with a phillips screwdriver from the operating link side to prevent rotation.
- o Coat the rotating shaft part of the link lightly with oil after reassembly.

Oil: clock oil (Squalol L-3)

— [Figure 62]

Brake

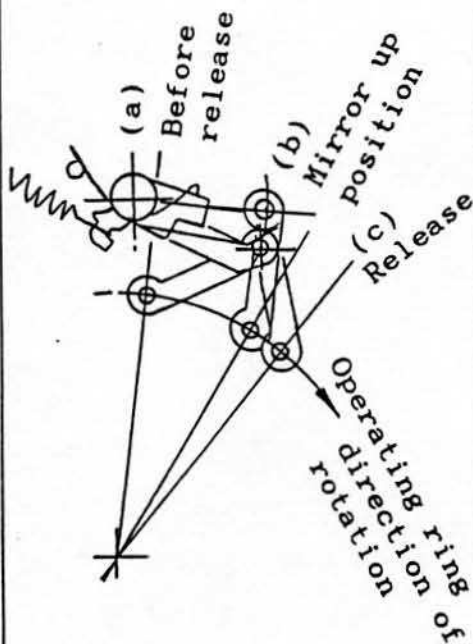

(Looking at the back of the camera pointing down.)

Description of the brake system

When the operating link starts to rotate when the S. release button is pressed in status (a) before release, the operation of the link applies the brake. At the mirror up position (b), the link operation begins to assist the rotation of the operating ring and force (c) is required to release the shutter even without the inertia of the operating ring.

Sketch

Explanation

[Figure 63]

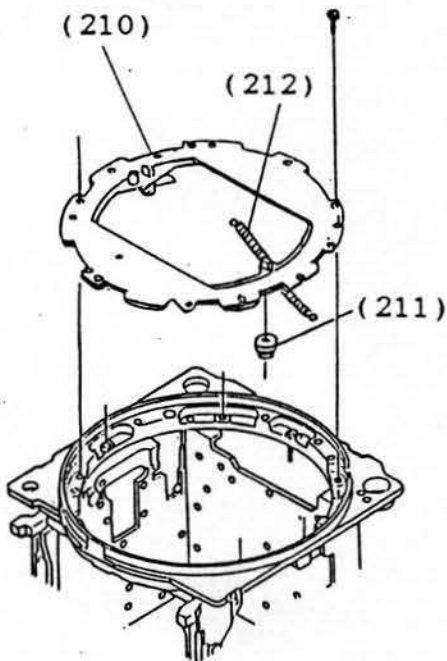
Operation ring removal

- * It is necessary to remove the bottom cover first before removing the operating ring unit.

1. Remove 7 screws and remove the operating ring unit (210).

Screws: panhead type 1 (95813357)
M1.7x3.5-B x 7 screws

2. Disengage the hook of the operating ring collar (212).
3. Uncouple the operating ring and brake.
--- Refer to page 26.
4. Use care not to drop the operating ring collar (211) inside the camera body.

--- [Figure 63]

- Unit disassembly -

[Figure 64]

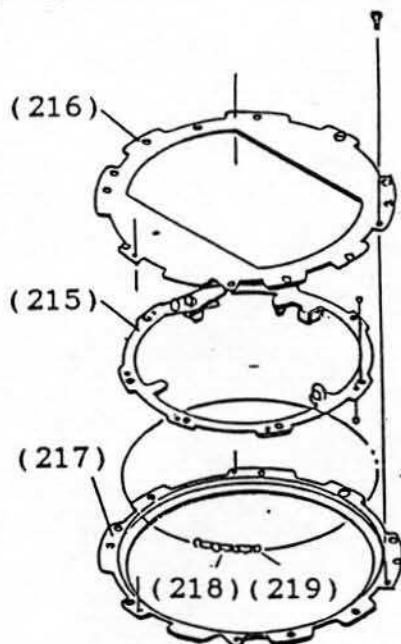

- 1) Loosen the 3 screws to disassemble the unit.
--- [Figure 64]

- 2) Check the flatness of the operating ring itself (215). Also check the operating-upper plate (216) and operating-lower plate (217) for sticks and wear.

- 3) Replace any part showing signs of wear. If sticks and light, coat lightly with oil.

Oil: clock oil (Squalol L-3), etc.

* Reassembly notes

- o Install the steel balls (219) after removing all rustproofing oil.

Steel balls: 48 balls, 1.6mm diameter (95770030)

Ball support ring (218): 24

--- [Figure 65]

[Figure 65]

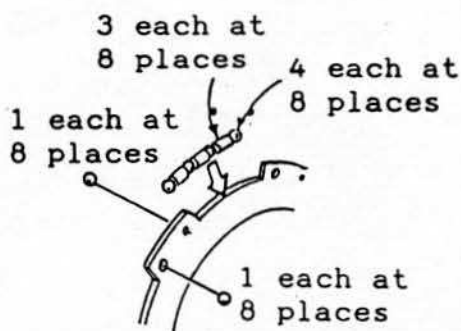

- o When reinstalling, use care to prevent the intrusion of foreign matter such as dirt, chips, etc., into the operating part of the operating ring.

Sketch

[Figure 66]

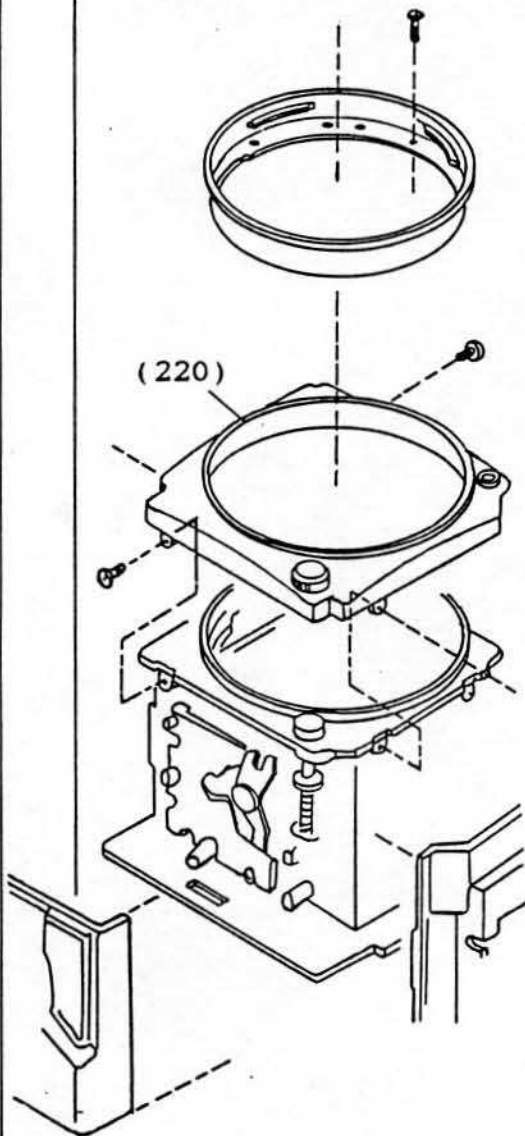

[Figure 67]

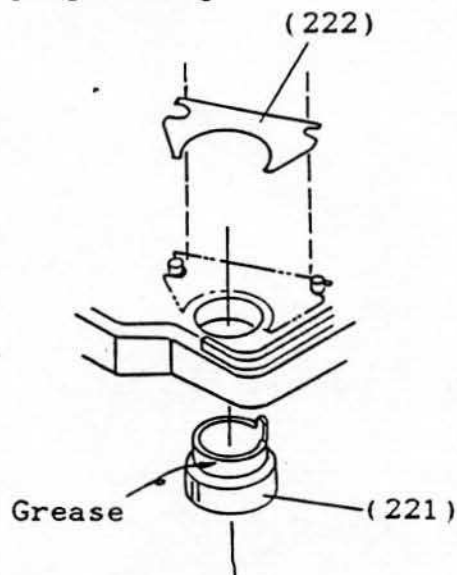

Explanation

Front cover removal

1. The mount, left and right covers and bottom cover must be removed before the front cover (220) can be removed.

Screws: panhead type 2 (96873357)
M1.7x3.5-B x 4 screws

--- [Figure 66]

* Reassembly notes

- 1) S. button ring (221) reassembly.
 - o Coat the rotating part of the S. button ring lightly with grease.

Grease: Photolub H-26

- 2) The S. ring holder plate (222) should be engaged in the front cover boss.

--- [Figure 67]

- 3) It is not necessary to strongly tighten the front cover screws. But they should not come loose!!

Sketch

Explanation

[Figure 68]

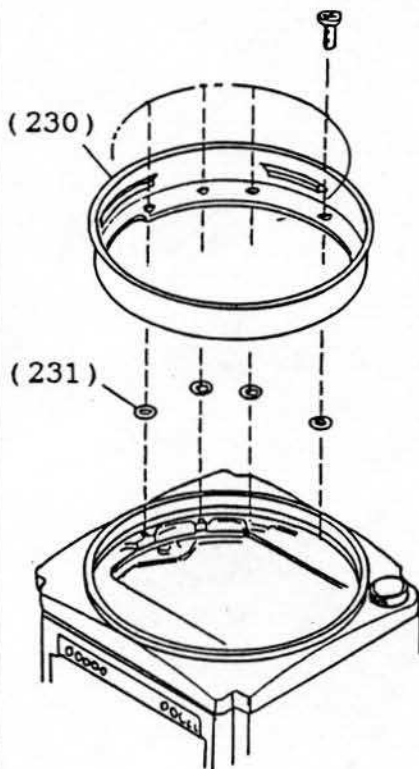

Lens mount removal

1. Remove the 9 screws and remove the lens mount (230).

Screws: panhead type 1 (95815405)
 M2.0x4.0-Ni x 9 screws
 --- [Figure 68]

Note 1: Do not drop washers (231) inside the body.

Washer: O.D.: 3.5mm, I.D.:
 2.1mm. t=0.1, 0.05
 (95520301) (95520311)

Note 2: The ETRS' L. mount is not compatible. Mounting is possible but the functions will not operate correctly.

(How to distinguish the difference)

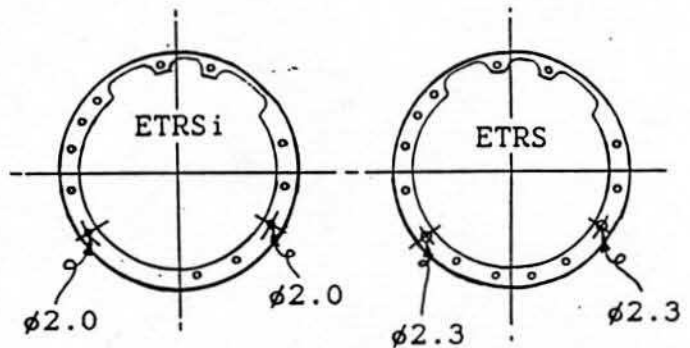

[Figure 69]

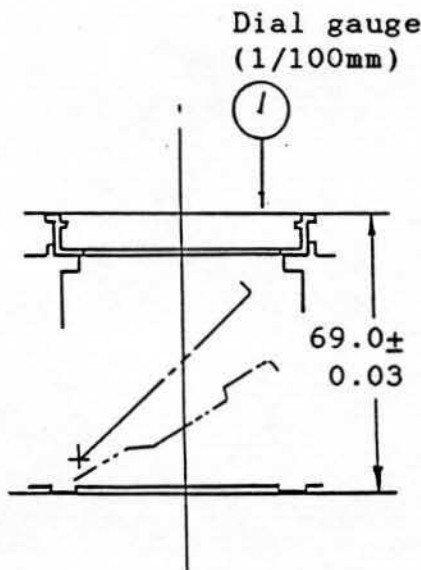

* Reassembly notes

1. Use the dedicated height gauge and a dial gauge to adjust the body back (69.0mm).
 --- [Figure 69]

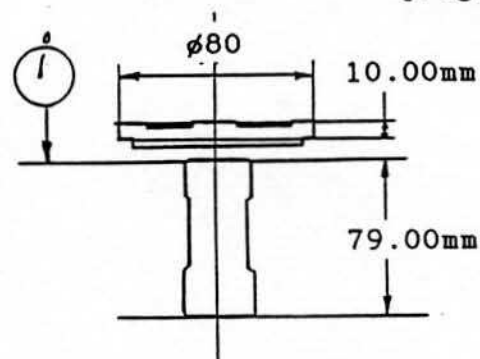

2. After adjustment

Mechanical body back = 69.0 ± 0.03mm
 Parallelism: 0.06/80 or less

Sketch

Explanation

[Figure 70]

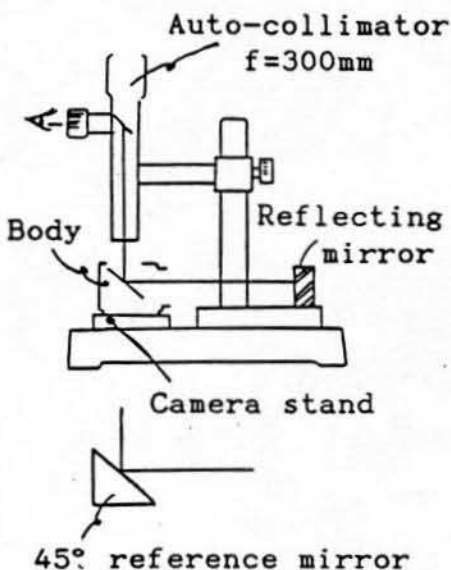

Mirror 45° adjustment

* The mirror is accurately adjusted to an angle of 45° during the assembly process at the factory and normally does not require adjustment. Use the following procedure if readjustment should become necessary.

1. When the following measuring instruments are available.

- o f=300mm auto-collimator
- o 45° reference mirror
- o Camera stand

--- [Figure 70]

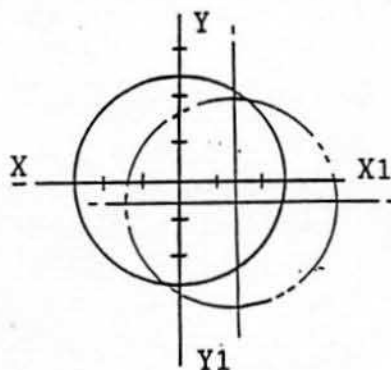

Y-Y1 direction:
15' or less

X-X1 direction:
20' or less

[Figure 71]

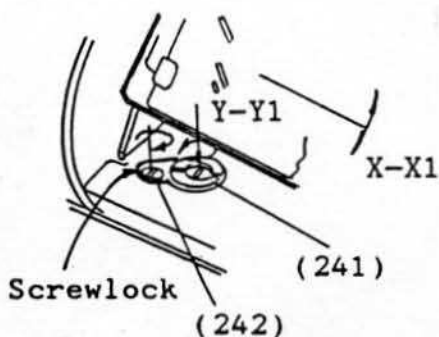

1) Mount the body on the camera stand and adjust the mirror adjustment collar (241).

2) Use the mirror adjustment collar to adjust the Y-Y1 direction and adjust the X-X1 direction by twisting the mirror frame.

3) After adjusting, tighten the mirror stop screw (242) to prevent movement and coat the screw with Screwlock to prevent loosening.

Screw locking agent: Three Bond #1401B

--- [Figure 71]

[Figure 72]

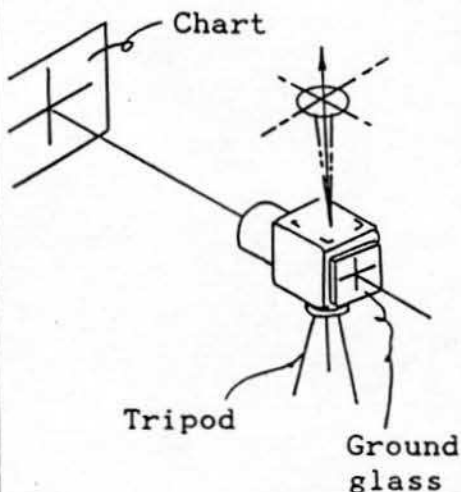

2. Without measuring instruments

o Draw a cross mark on paper and fasten to a nearby wall.

o Prepare a ground glass the size of the image frame and with a cross mark in the center. Position the ground glass at the back of the camera and adjust so that the images of the cross on the wall are the same when viewed on the ground glass and through the camera viewfinder.

--- [Figure 72]

Sketch

Explanation

[Figure 73]

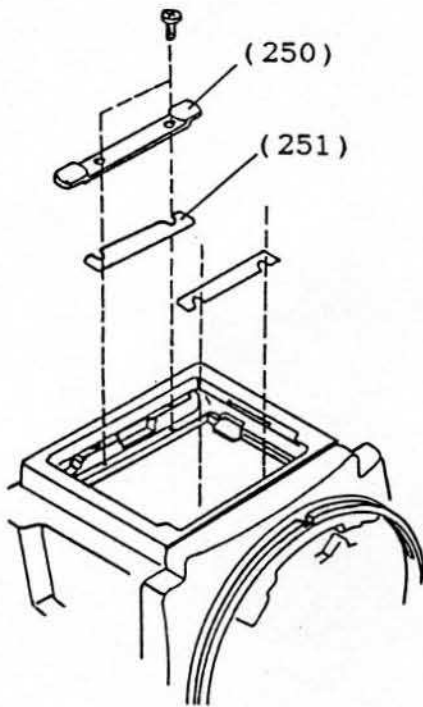

Focusing adjustment

- Using a collimator -

f=500-1000mm infinity collimator
Reference lens: dedicated 75mm f/2.8
10X loupe

- o Adjust by inserting adjusting liners under the F. screen base until the collimator chart image is sharply focused.

Screws: panhead type 1 (95813357)
M1.7x3.5-B x 4 screws

--- [Figure 73]

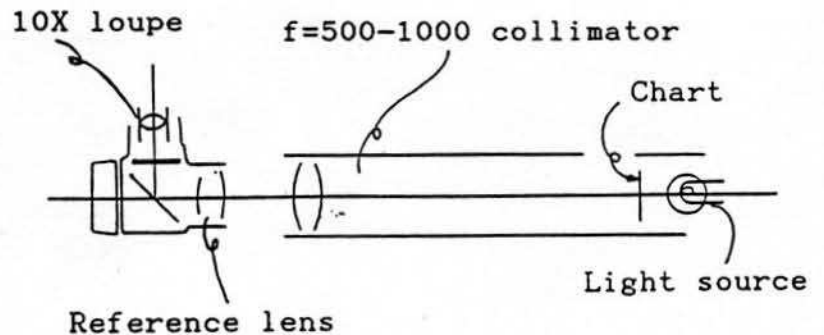

[Figure 74]

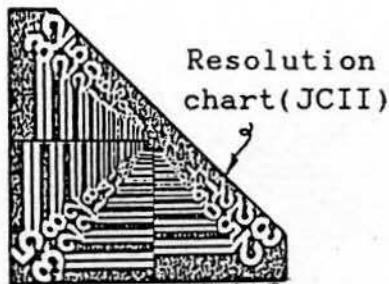

- Without a collimator -

Resolution chart (JIS triangular chart, etc.)
10X loupe
Ground glass, 63 x 50mm

--- [Figure 74]

[Figure 75]

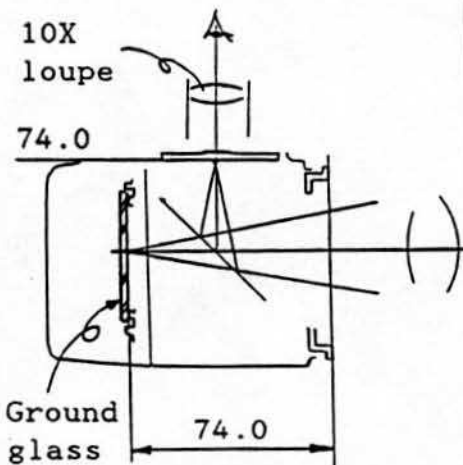

- o Fasten the resolution chart on a wall at the distance of 2-3m and mount the camera on a tripod.

- o Place the ground glass on the firm rails at the back of the camera, use the 10X loupe and adjust for the sharpest focus.

- o Adjust the focusing plate so that it indicates the distance at which the camera is focused.

--- [Figure 75]

Circuit board names and wiring diagram 2

Battery checking LED

Adjust with Vr-3.

Shutter speed

Adjust with Vr-1.

TTL-sensor

Adjust with Vr-2 and Vr-4.

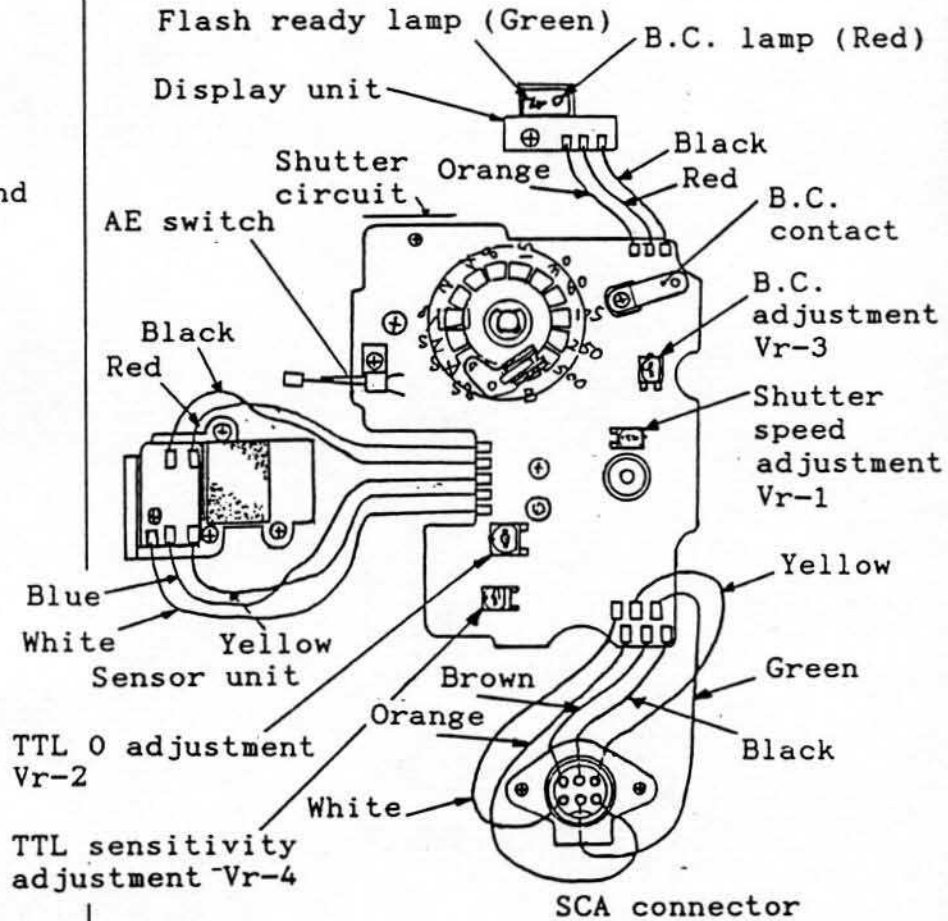

o Do not make any adjustments until all of the following have been checked.

1. Wiring errors.
2. Poor soldering
3. Missing parts
4. Broken wires

Sketch

Explanation

[Figure 76]

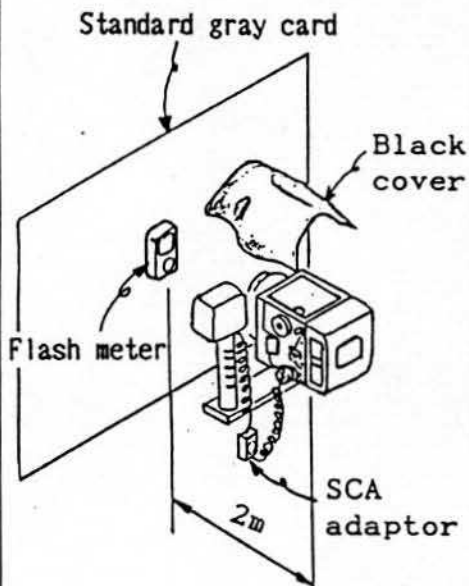

Sensor adjustment

- o Always adjust the sensor after replacing the shutter circuit or sensor circuit.

Required materials

- o Flash 60-CT4 (TTL mode)
- o SCA adaptor (SCA-386)
- o Standard gray card (22% reflectance ratio), height 1.2m x width 1.4m or more.
- o Flash meter
- o Ammeter (microamperes)
- o Standard lens: 75mm f/2.8 (Set to f/8)

--- [Figure 76]

1. Prepare the materials.

[Figure 77]

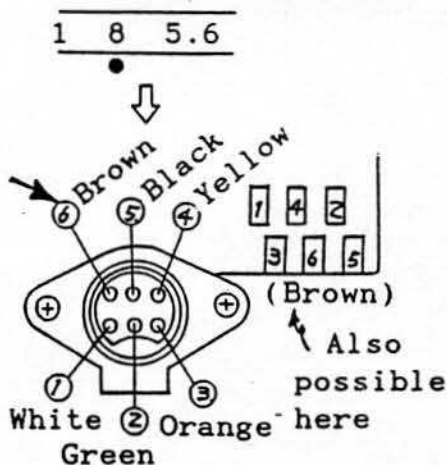

- o Set the lens aperture to f/8.
- o Release the shutter (the multi-lever can be at double exposure).
- o Connect the ammeter to the SCA adaptor pin (brown) and ground.
- o Cover the sensor to prevent the entry of light.

--- [Figure 77]

2. Adjustment

1) Make the zero adjustment.

- o Use Vr-2 and set to 0.2 ± 0.25 microampere (0.175 - 0.225 microampere).

[Figure 78]

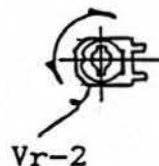
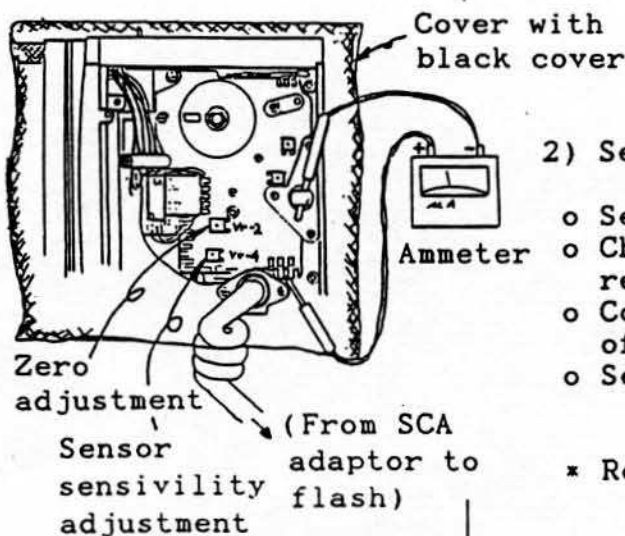

--- [Figure 78]

2) Sensor sensibility adjustment

- o Set the SCA adaptor to ISO100.
- o Check if the green mark of the flash ready lamp lights.
- o Cover the sensor to prevent the entry of light.
- o Set the flash meter to ISO100.

--- [Figure 79]

* Release the shutter to fire the flash.

Sketch

Explanation

[Figure 79]

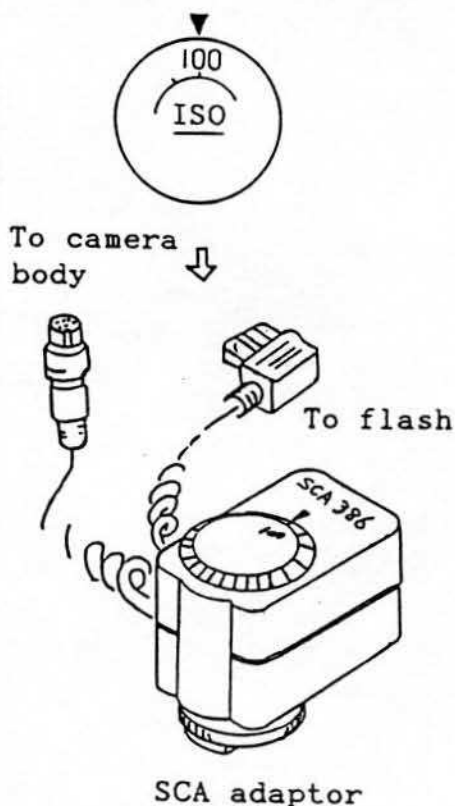

o Adjust Vr-4 so that the flash meter displays f/8.0 f/5.68 f/8.02.



Vr-4 (slightly smaller than Vr-2)

* Repeat at ISO50 and ISO200 as a check.

ISO50: f/11 f/8.02 f/11.80

ISO200: f/5.6 f/4.02 f/5.68

If "NG" appears, repeat the adjustment at ISO100.

Note 1: During the above operations, check if the \sphericalangle mark of the flash ready lamp in the viewfinder lights.

Note 2: Since the flash power supply is used, plug the SCA connector into the camera body.

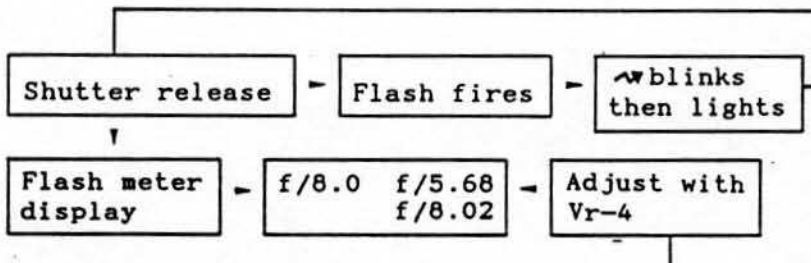

Checks

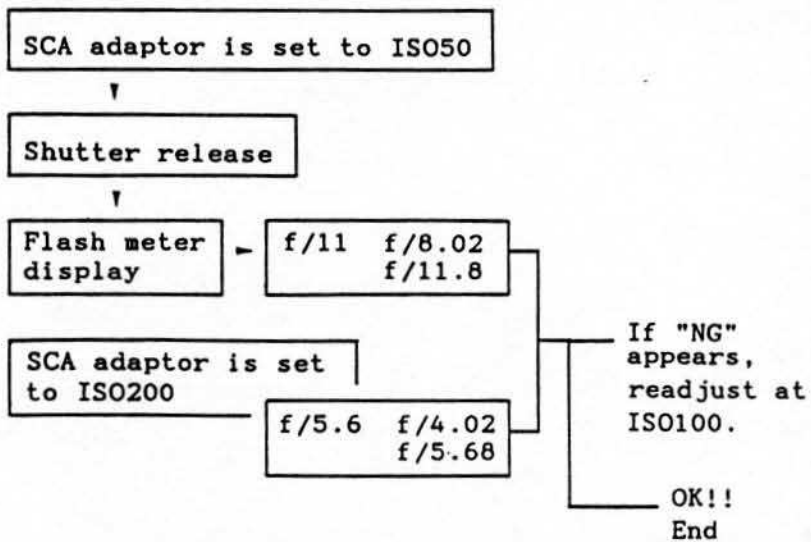

(E T R S i)

Sketch	Explanation
	MEMO

TROUBLESHOOTING GUIDE

- [] This troubleshooting guide describes possible malfunctions, remedies and adjustment methods for your reference when making repairs and adjustments.

Sketch

Explanation

[Figure 1]
Winding unit rear view

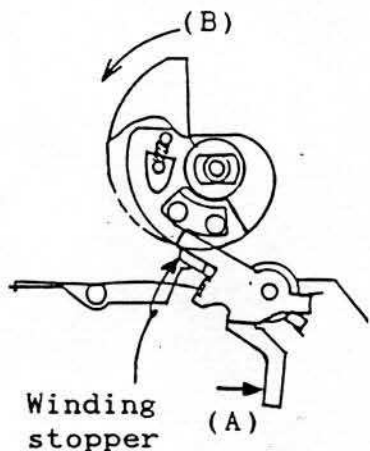

Troubleshooting flow

Film advance system.

Film will not advance.

The winding stopper will not release.

When the winding stopper is not released by (A), (B) cannot move.

[Figure 1]

[Figure 2]
Winding unit front view

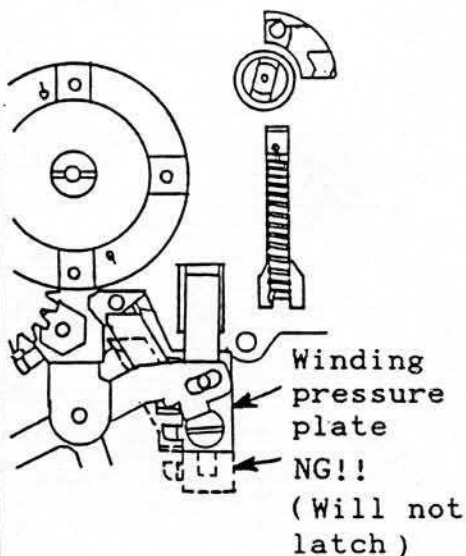

Film advance will not stop in one 360° rotation...

Film back malfunction.

- o When winding stopper in [Figure 1] does not disengage.
- o The winding pressure plate does not operate properly when the mirror is up.

[Figure 2]



Sluggish, uneven winding.

Operating ring rotation is sluggish.
 The winding unit requires lubrication.
 Movement of the M. operating board is sluggish.

----- P 27

----- P 4

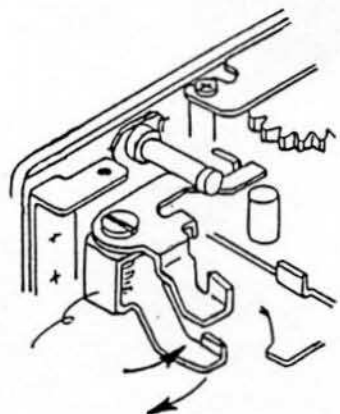
----- P 4 - 12

Sketch	Explanation
<p data-bbox="203 207 392 238">[Figure 3]</p> 	<p data-bbox="713 207 1097 238"><u>Troubleshooting flow</u></p> <p data-bbox="721 269 1027 300">Shutter system</p> <p data-bbox="760 341 1340 383">The shutter will not release.</p> <p data-bbox="705 404 1058 476">Lens not properly mounted.</p> <p data-bbox="1121 404 1489 476">The F. release pin does not return.</p> <p data-bbox="736 507 1481 611">The F. winding safety lever (lower) of the F. release unit does not operate properly [Figure 3].</p> <p data-bbox="768 642 1434 714">The shutter release sound is made, but the sector is not open.</p> <p data-bbox="776 745 1238 922">Operating ring rotation is sluggish. Movement of the mirror operating board is sluggish.</p> <p data-bbox="776 942 1497 984">The shutter speed can't be controled.</p> <p data-bbox="776 1004 1246 1118">Defective lens shutter. Defective electrical system.</p> <p data-bbox="776 1139 1324 1181">The sector can't be closed.</p> <p data-bbox="776 1201 1246 1315">Defective lens shutter. Defective electrical system.</p> <p data-bbox="729 1357 1215 1398">Mirror operating system.</p> <p data-bbox="760 1419 1340 1460">Mirror operation is sluggish.</p> <p data-bbox="713 1481 1058 1595">Operation of the lens set ring is sluggish.</p> <p data-bbox="1121 1481 1489 1595">Movement of the M. operating board is slúggish.</p>
<p data-bbox="211 1605 407 1636">[Figure 4]</p>  <p data-bbox="203 1989 666 2072">* Check if the operating ring returns properly when force is applied</p>	<p data-bbox="823 1636 1301 1719">Operation ring rotation is sluggish.</p> <p data-bbox="721 1750 1528 1895">Advancing the film one frame, hold the cocking pin, release the shutter and check if the operating ring returns properly when force is applied [Figure 4].</p>

Sketch

Explanation

[Figure 5]

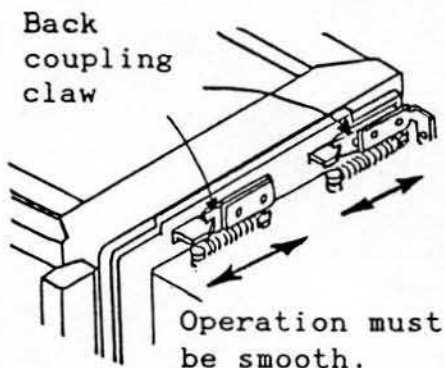

Troubleshooting flow

Mounting related

The lens cannot be mounted.

Lens mount spring too tight.

Protruding lens connector pin.

The film back cannot be mounted.

Back coupling claw does not operate correctly.

[Figure 5]

[Figure 6]

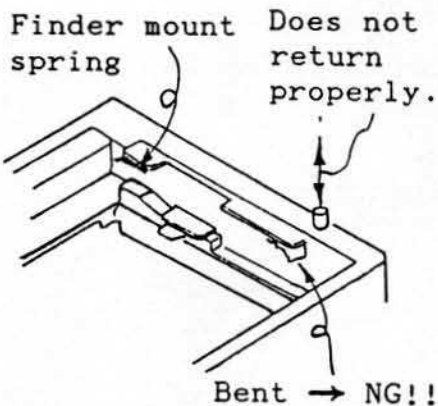

The finder cannot be mounted.

The F. lock pin does not return properly.

Bent finder mount spring.

[Figure 6]

Dis-mounting related

The lens cannot be removed.

Insufficient L. release pin stroke.

[Figure 7]

[Figure 7]



The film back cannot be removed.

The F. release pin of the film back side is off track.

The finder cannot be removed.

The finder release button cannot be depressed.

Due to impact

Sketch

Explanation

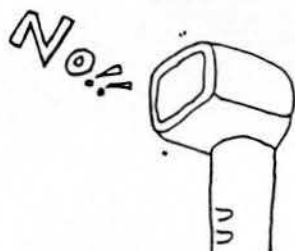

Troubleshooting flow

Flash synch related

When the flash will not be fire.

Defective shutter unit.

Electrical system malfunction.

At improper TTL-direct auto flash control.

Electrical system malfunction.

When the auto-flash control doesn't function.

When the manual flash doesn't fire at full output.

Is there an open or a short?

Sensor unit wire
SCA connector wire

↓ Yes

Are adjustments correct?

Check and readjust

↓ NG

Replace the sensor unit.

↓

Readjust

↓ NG

Replace the shutter circuit unit.

Adjust

(E T R S i)

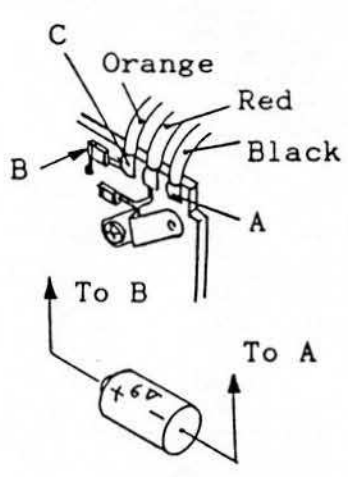
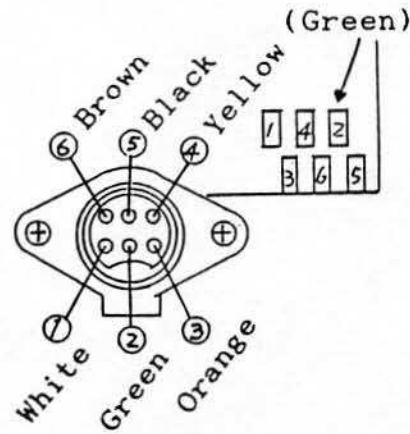
Sketch	Explanation
<p>[Figure 10]</p>   <p>Connect a tester between the (2) pin and C land.</p> <p>Conductance: OK</p> <p>Between the (2) pin and the (5) pin or other ground.</p> <p>Conductance: NG</p>	<p><u>When the flash ready indicator (green) does not light.</u></p> <div style="border: 1px solid black; padding: 5px; margin: 10px 0;"> <p>o When normal, the flash ready indicator operates as follows:</p> <ul style="list-style-type: none"> - When the flash is charged: lights - When the flash is discharged at the auto flash control: blinks and again lights when the flash is recharged. - When the flash is discharged at the manual control: goes out and again lights when the flash is recharged. </div> <div style="display: flex; justify-content: space-around; margin: 10px 0;"> <div style="border: 1px solid black; padding: 5px; width: 45%;"> <p>Is there an open or a short?</p> </div> <div style="border: 1px solid black; padding: 5px; width: 45%;"> <p>Display unit wire. SCA connector wire.</p> </div> </div> <p style="text-align: center;">↓ Yes [Figure 10]</p> <div style="display: flex; justify-content: space-between; margin: 10px 0;"> <div style="border: 1px solid black; padding: 5px; width: 60%;"> <p>Is the LED brown?</p> <p>Apply 6V to A land (-) and B resistor (+).</p> </div> <div style="width: 35%;"> <p>Does not light.</p> <div style="border: 1px solid black; padding: 5px; margin-top: 10px;"> <p>Replace the display unit.</p> </div> </div> </div> <p style="text-align: center;">↓ Yes [Figure 10]</p> <div style="display: flex; justify-content: space-between; margin: 10px 0;"> <div style="border: 1px solid black; padding: 5px; width: 45%;"> <p>Replace the S. circuit board.</p> </div> <div style="width: 45%;"> <p>Adjust the sensor.</p> </div> </div>

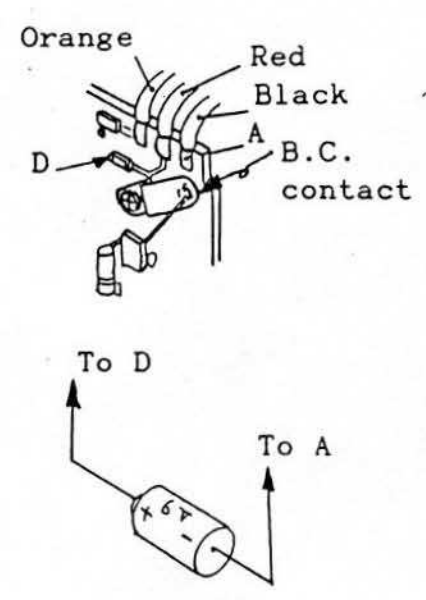
Sketch	Explanation
<p>[Figure 11]</p> 	<p><u>When the battery checked LED (red) does not light.</u></p> <div style="border: 1px solid black; padding: 5px; margin-bottom: 10px;"> <p>o When normal, the battery check LED (red) lights when batteries (6V) are loaded and the B.C. contact is pressed with shutter and lighted.</p> </div> <div style="border: 1px solid black; padding: 5px; margin-bottom: 10px;"> <p>Does the shutter closing signal light?</p> </div> <div style="border: 1px solid black; padding: 5px; margin-bottom: 10px;"> <p>Does the B.C. contact touch the land? No → Loose contact screw or dirty contact.</p> </div> <p style="margin-left: 40px;">No ↓ Yes</p> <div style="border: 1px solid black; padding: 5px; margin-bottom: 10px;"> <p>Is there an open or a short? A display unit wire or battery box wire is pinched.</p> </div> <p style="margin-left: 40px;">↓ Yes</p> <div style="border: 1px solid black; padding: 5px; margin-bottom: 10px;"> <p>Is the LED blown? Does not light.</p> <p>Apply 6V to A land (-) and D resistor (+). → Replace the display unit.</p> <p style="text-align: center;">[Figure 11]</p> </div> <p style="margin-left: 40px;">↓ Lights. DC regulated power supply</p> <div style="border: 1px solid black; padding: 5px; margin-bottom: 10px;"> <p>Adjust the battery check. (Vr-3) 4.7V: does not light. Adjust. 4.9V: lights.</p> </div> <p style="margin-left: 40px;">↓ Does not light.</p> <div style="border: 1px solid black; padding: 5px; margin-bottom: 10px;"> <p>Replace the S. circuit board. Adjust the sensor.</p> </div> <p style="margin-left: 40px;">o Use a regulator which can withstand 0.1A or more and 6V or more.</p>

Sketch

Explanation

[Figure 12]

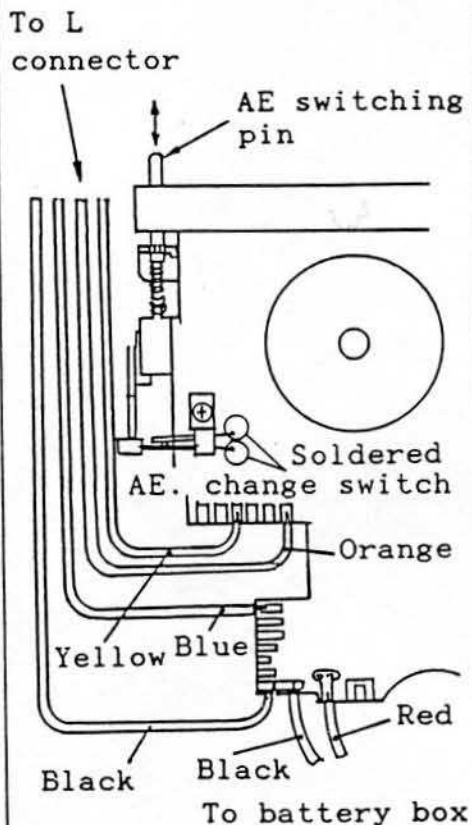

When the shutter speeds are not normal

o When normal, all shutter speeds shall be within the ratings with a battery (6V) installed an a 75mm f/2.8 lens.

When the shutter speed is fixed only at 1/500 sec.

Is the AE change switch contact?

No Adjust by bending the contacts.

AE switching pin
Press: the contacts separate
Release: the contacts touch

↓ Yes

Is there an open or a short?

Lens connector orange, black and blue wires.
Improper AE change switch soldering.
Pinched battery box wire.

↓ Yes

Replace the S. circuit board.

Adjust the sensor.

When the shutter stays open.

Is the yellow wire of the lens connector shorting to the body?

↓ OK

[Figure 12]

Replace the S. circuit board.

Adjust the sensor.

When the electronically-controlled speeds are not accurate.

A shutter tester is required.

Vr-1

Adjust at 1/2 sec. and check at 1/250 sec.

When there is no shutter tester.

Adjust at a slow shutter speed of 1 sec. - 2 sec.

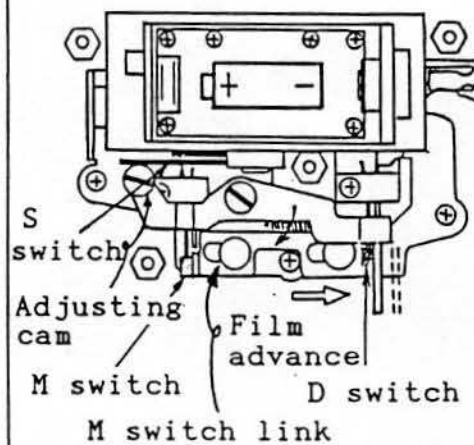
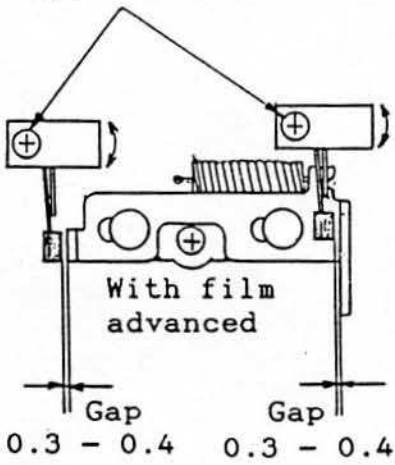
Sketch	Explanation
<p>[Figure 13]</p> 	<p>Function of the battery box unit switches</p> <ul style="list-style-type: none"> o Normal — All switches off. o Film advanced — M and D switches on. o Release stroke 1 — S switch on. <p>[Figure 13]</p> <p>Switch adjustments</p> <p>M switch —</p> <p>D switch —</p> <p>With the winding set on, adjusting so that there is a gap of 0.3 - 0.4mm looking from the bent part of the M switch link.</p>
<p>[Figure 14]</p> <p>Loosen the screw and adjust.</p>  <p>With film advanced</p> <p>Gap 0.3 - 0.4 Gap 0.3 - 0.4</p>	<p>[Figure 14]</p> <div style="border: 1px solid black; padding: 5px; width: fit-content; margin: 10px auto;"> <p>The gap is for positive turning on of the M. switch and D. switch.</p> </div> <p>The S. switch must turn on during stroke 1.</p> <p style="text-align: center;">↓</p> <p>Adjust by adjusting with the AE switch lever adjusting cam or by bending the S switch contact.</p>

Sketch

Explanation

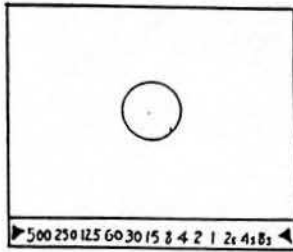

AE. finder display

[Figure 15]

AE connector

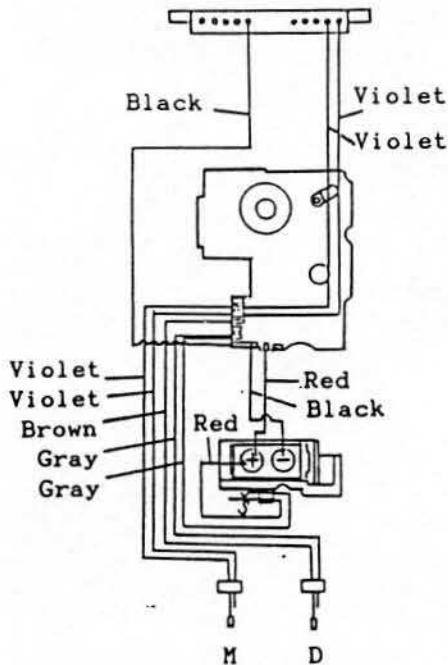

Improper AE. coupling

It is assumed that the AE. finder is operating correctly.

When the display does not light

Do the D switch and S switch turn on?

No

Poor contact or dirty contacts.

↓ Yes

Possible open.

Wires from the power supply to the switch and AE. connector. [Figure 15]

Dirty AE. connector contacts.

When the display does not change for underexposure

Does the M switch turn on?

No

Poor contact.

↓ Yes

Does the M switch turn off when the mirror raises?

No

Poor contact.

↓

Possible open.

- o Turn the switch on and off using the M switch timing gauge (01754500-PT).

(E T R S i)

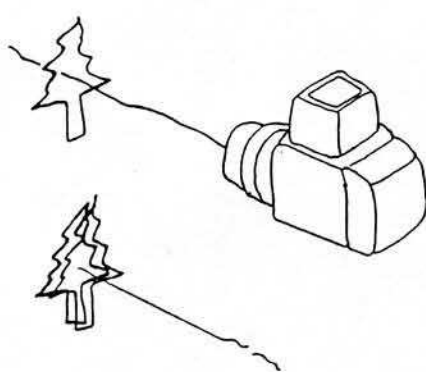
Sketch	Explanation
	<p data-bbox="752 207 1050 269">Focus related</p> <p data-bbox="854 310 1348 372">Inaccurate focusing (1).</p> <p data-bbox="807 414 1450 476">Defective focusing screen mount.</p> <p data-bbox="854 538 1348 600">Inaccurate focusing (2).</p> <p data-bbox="760 652 1113 745">Play in the lens mount.</p> <p data-bbox="1152 652 1466 745">Loose lens fit.</p> <p data-bbox="760 797 1113 890">Worn lens mount.</p> <p data-bbox="1152 797 1497 890">No spring in the lens mount.</p>

A B C D E F G H

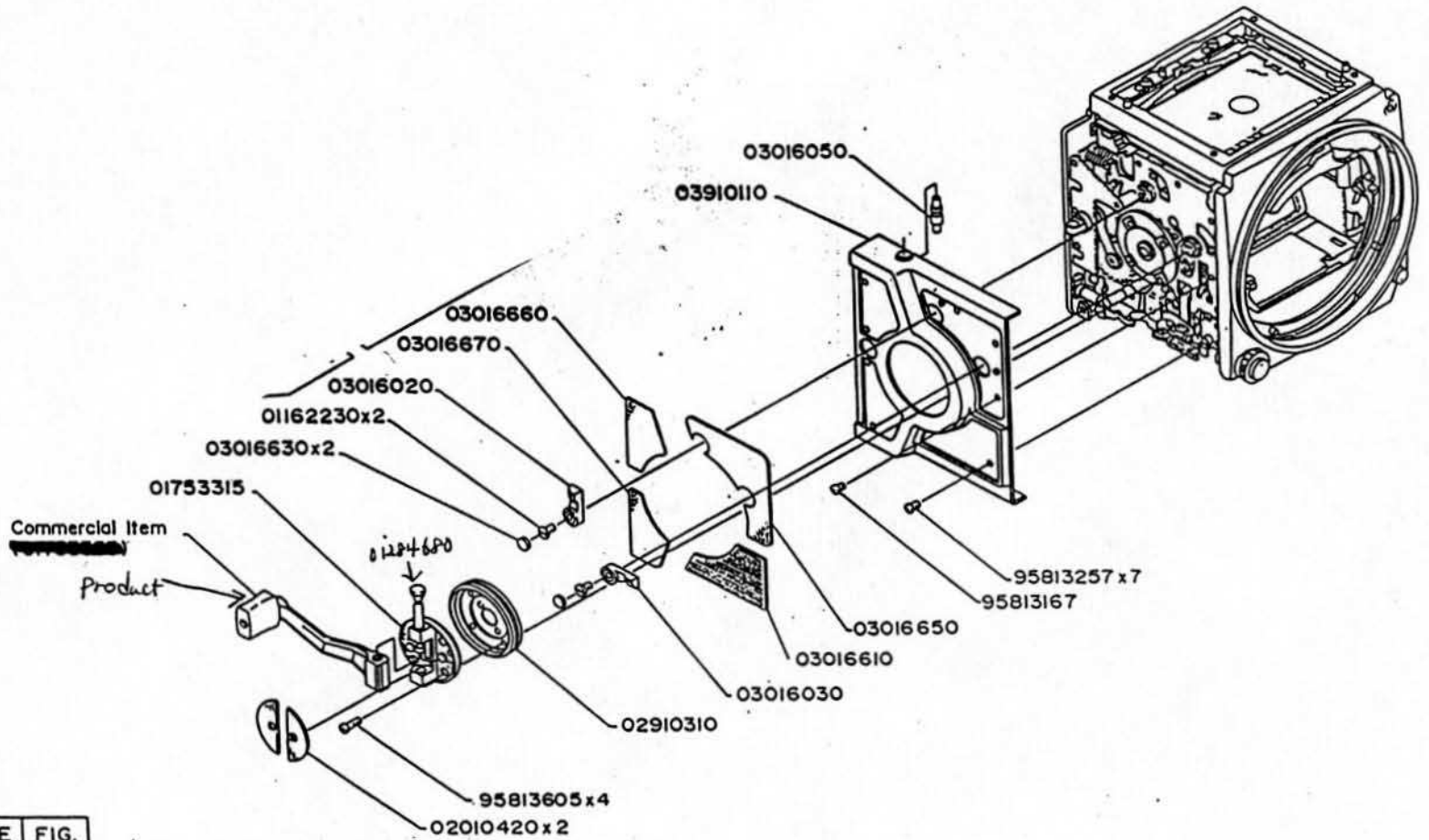

MODEL	CODE	FIG.
ETRSI CAMERA BODY	0301	1/9
BRONICA CO., LTD.		

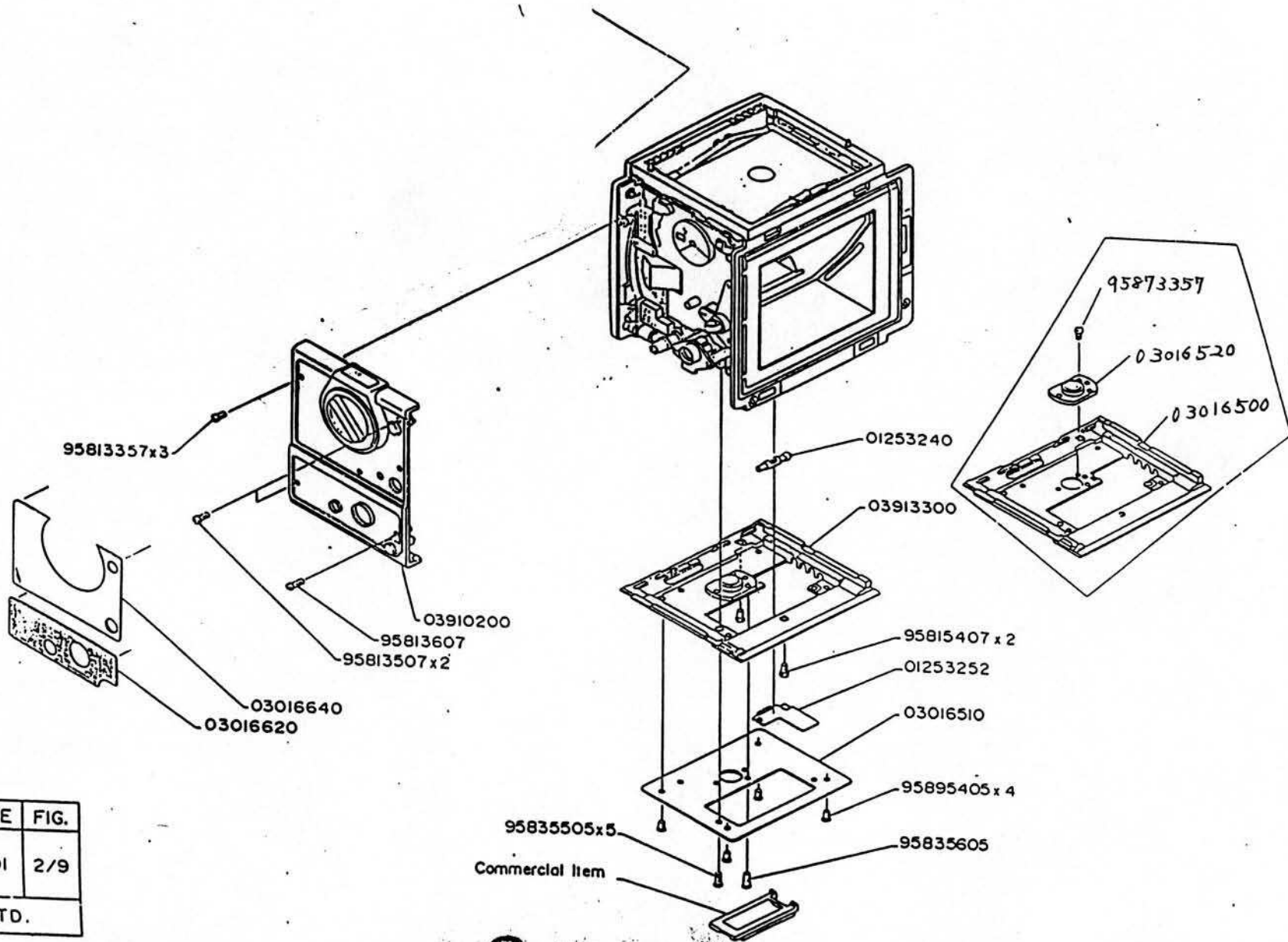

MODEL	CODE	FIG.
ETRSI CAMERA BODY	0301	2/9
BRONICA CO., LTD.		

DEC. '88

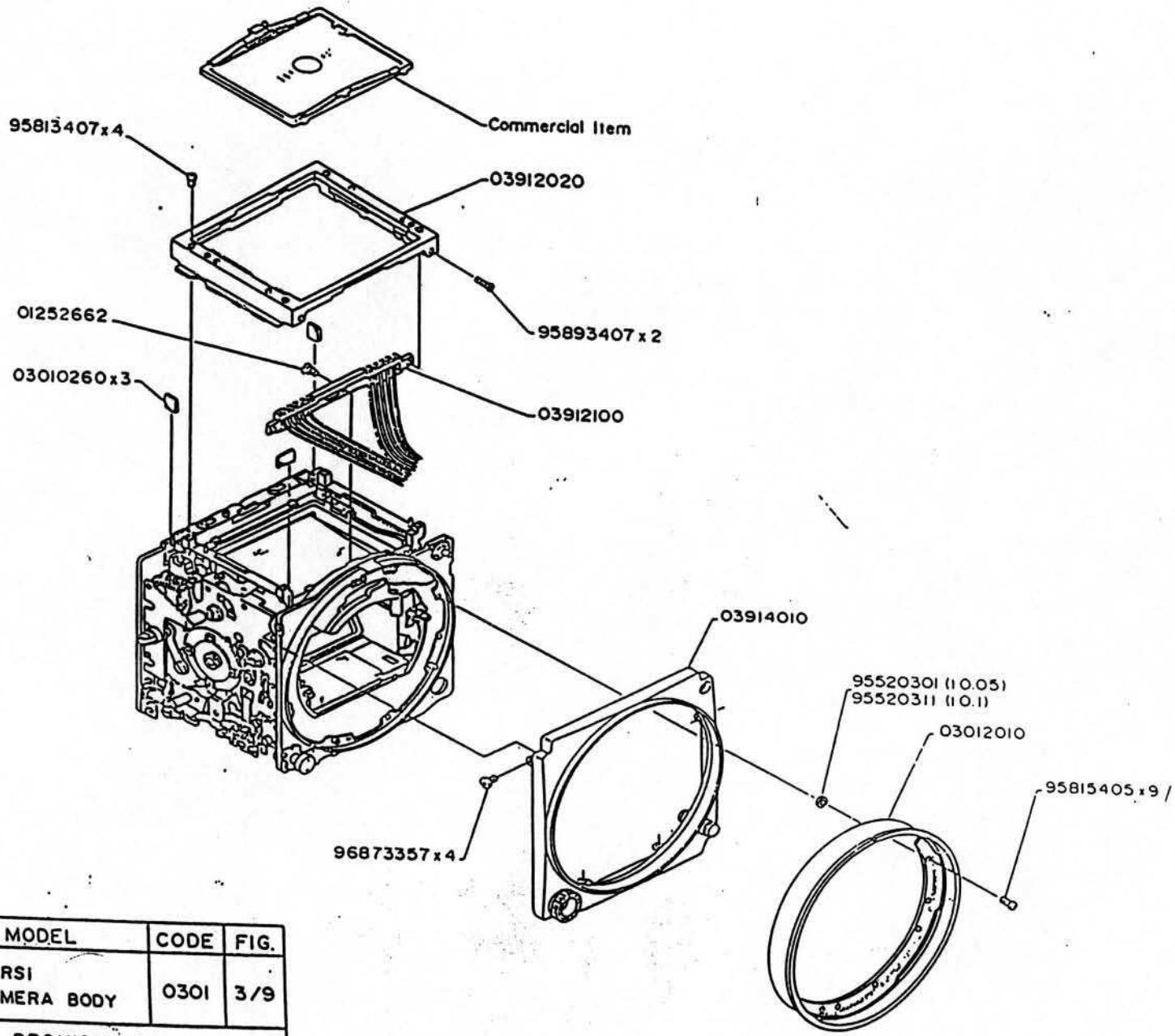

MODEL	CODE	FIG.
ETRSI CAMERA BODY	0301	3/9
BRONICA [®] CO., LTD.		

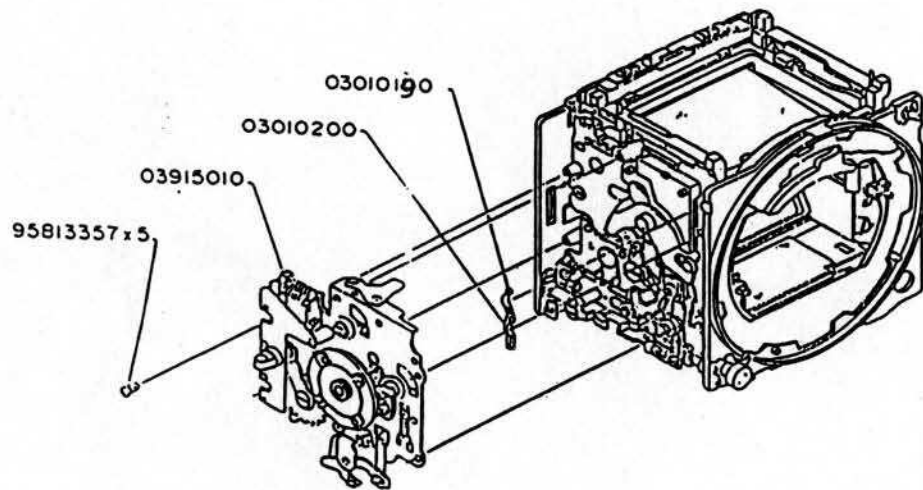

MODEL	CODE	FIG.
ETRSI CAMERA BODY	0301	4/9

B.F. CA. CO., LTD.

A

E

F

G

H

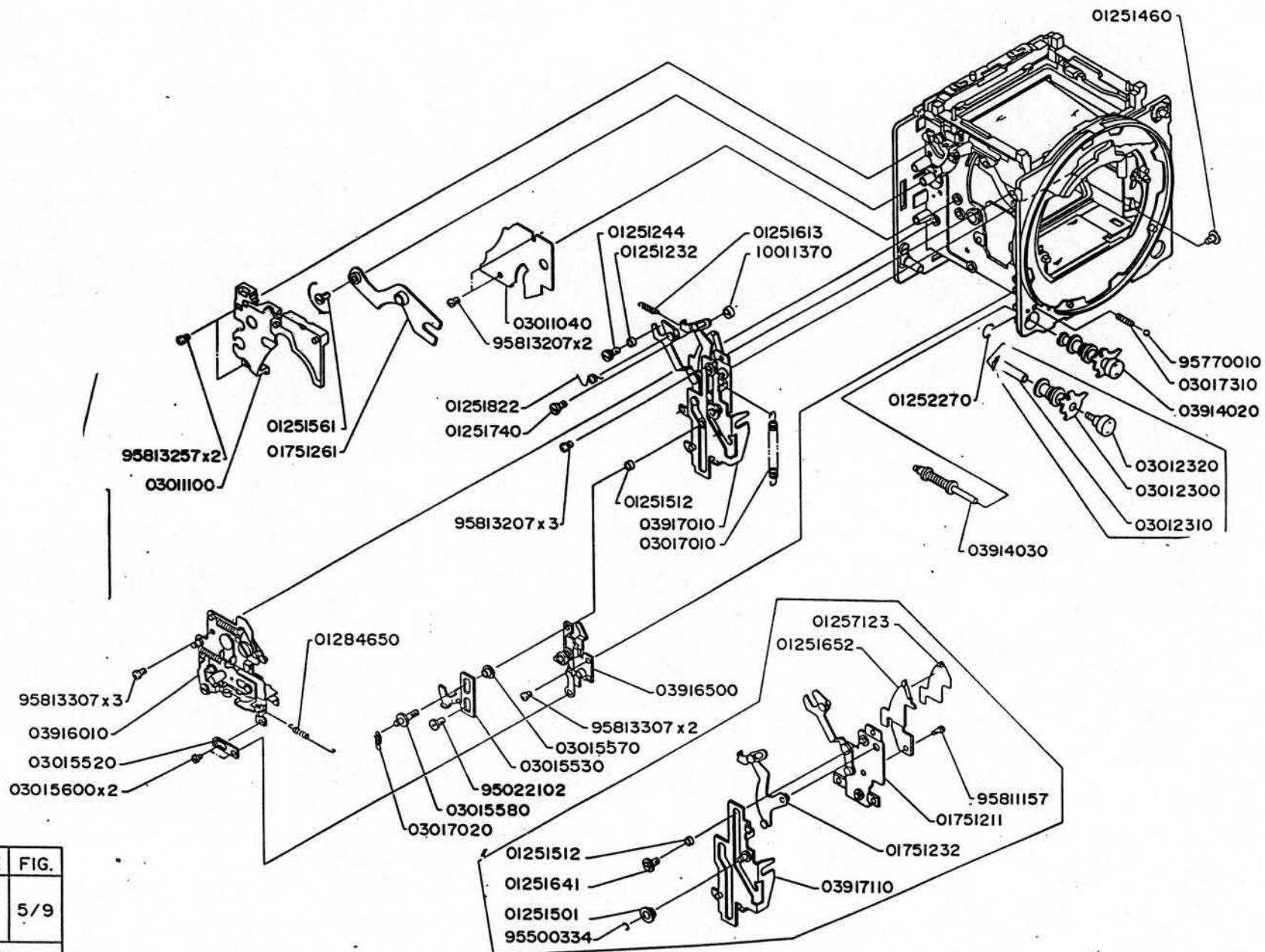

MODEL	CODE	FIG.
ETRSI CAMERA BODY	0301	5/9
BRONICA CO., LTD.		

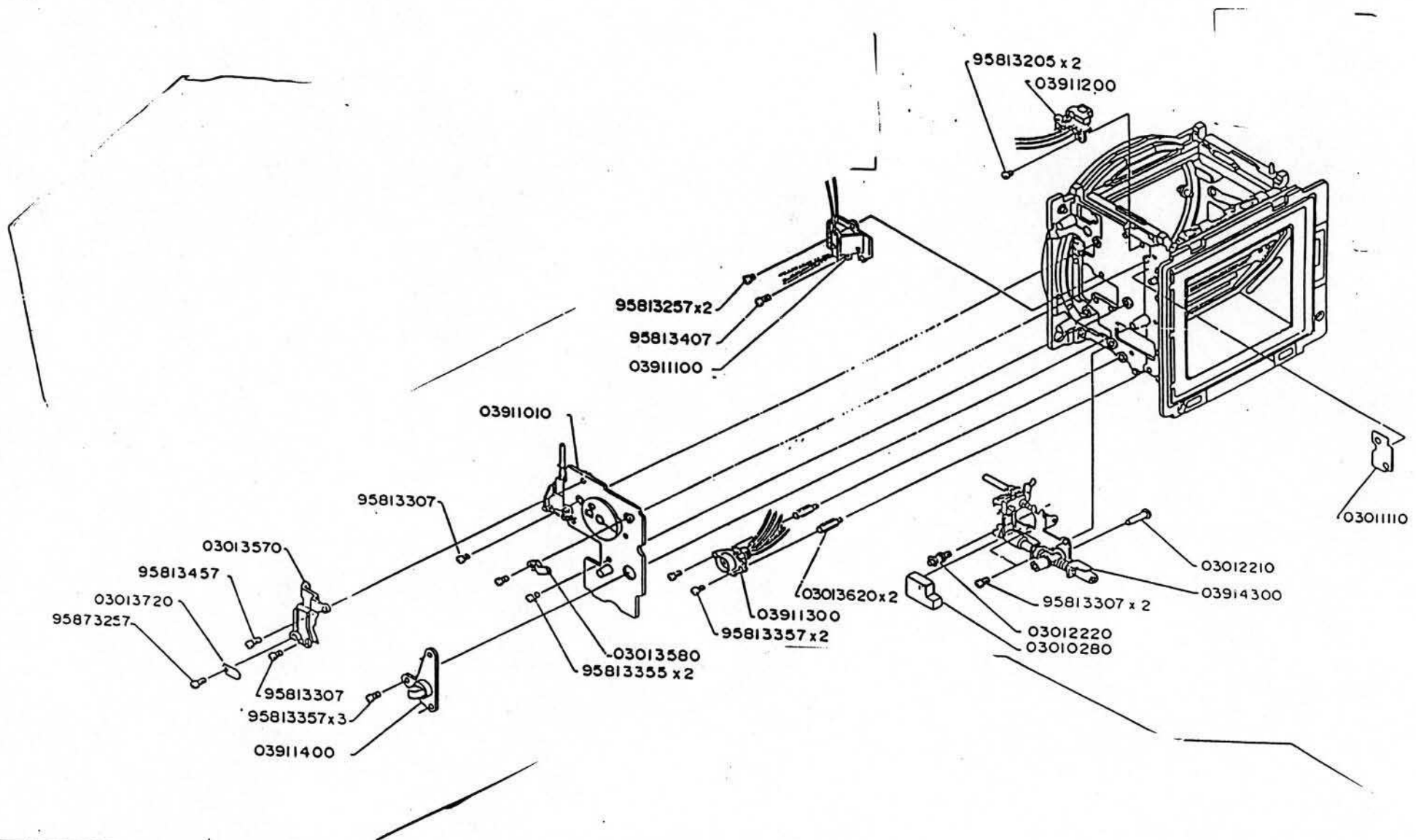

MODEL	CODE	FIG.
ETRSI CAMERA BODY	0301	6/9
BRONICA CO., LTD.		

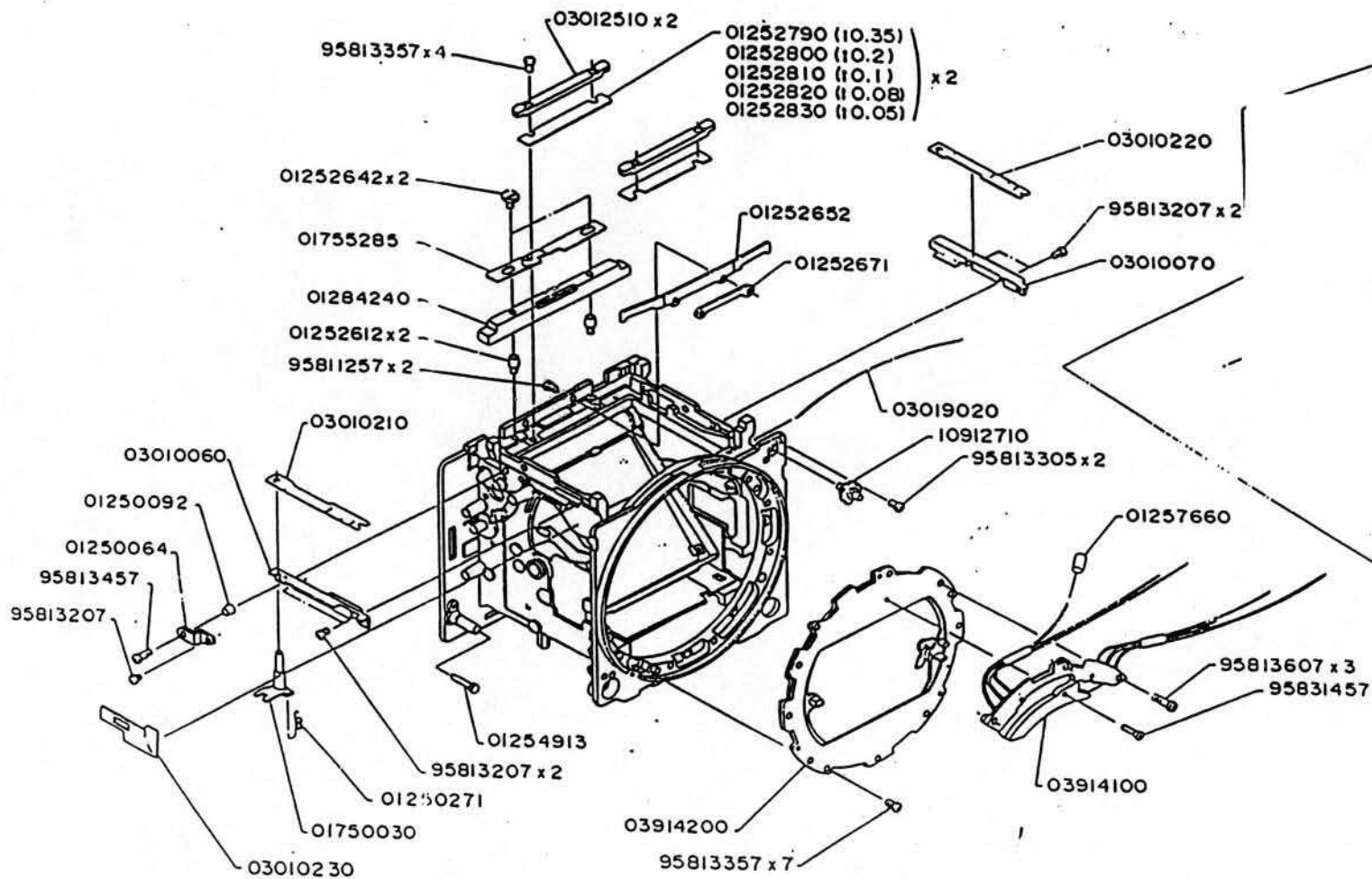

MODEL	CODE	FIG.
ETRSI CAMERA BODY	0301	7/9
BRONICA CO., LTD.		

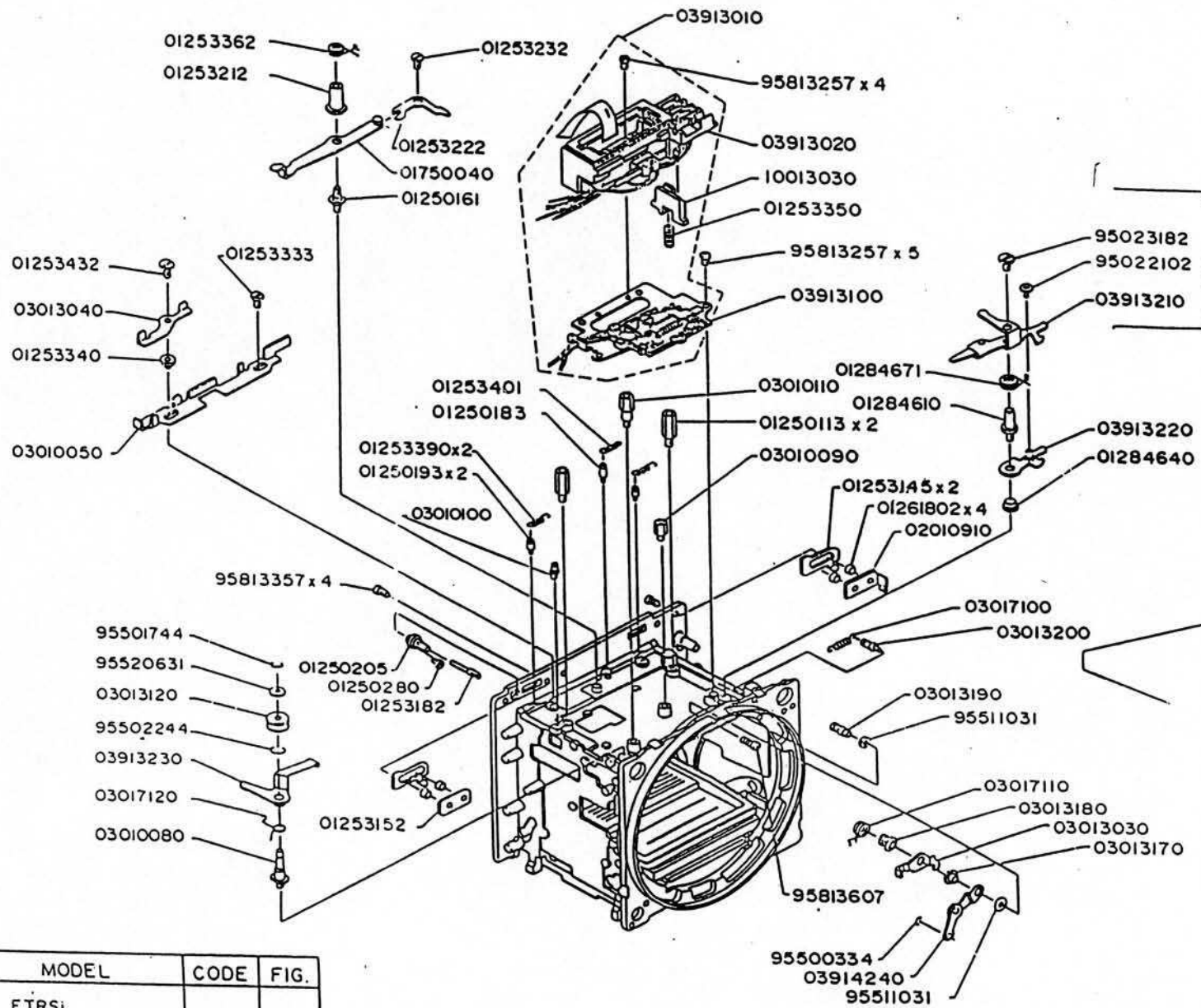

MODEL	CODE	FIG.
ETRSi CAMERA BODY	0301	8/9
BRONICA CO., LTD.		

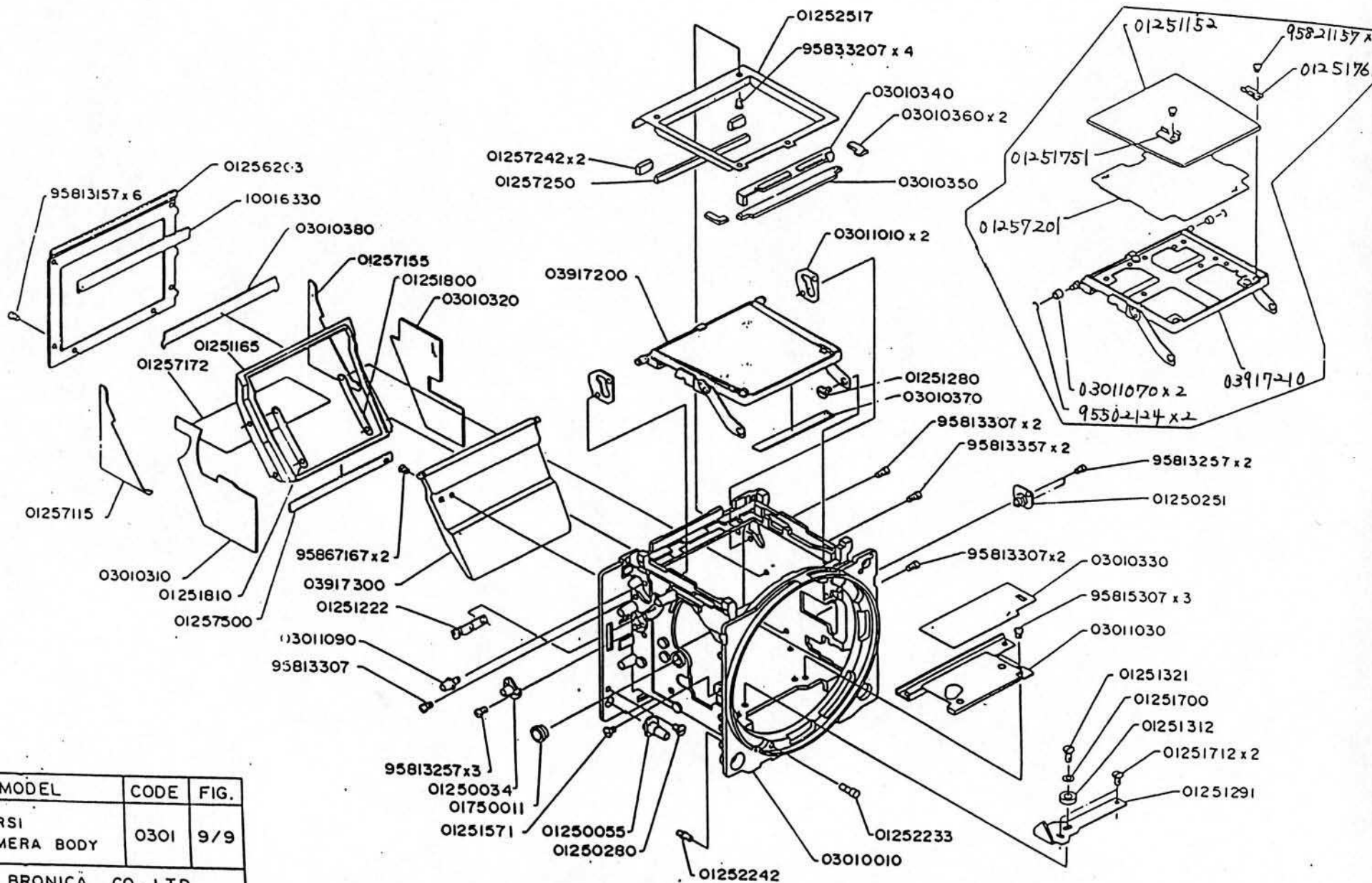

MODEL	CODE	FIG.
ETRSI CAMERA BODY	0301	9/9
BRONICA CO., LTD.		